

Health and safety at opencast mines, alluvial mines and quarries

GUIDANCE FOR OPERATORS

June 2025





These good practice guidelines give practical advice on health and safety control measures at opencast mines, alluvial mines and quarries.

ACKNOWLEDGEMENTS

WorkSafe New Zealand would like to acknowledge and thank the stakeholders who have contributed to the development of this guidance.

Health and safety at opencast mines, alluvial mines and quarries

KEY POINTS

- Have a well-planned, designed and maintained work site, using an appropriate system to manage health and safety risks.
- All workers must be trained and competent for the work they do, including the required certification.
- Notify the site location and nature as well as the manager's details to WorkSafe.
- Use in-guard nip guarding for conveyors, as well as idler nip guards.
- Ensure there is a safe procedure for tipping.
- Apply safe systems of work for transport, storage, use and disposal of explosives.
- Provide separate roads for light and heavy vehicles, where practicable. Otherwise, ensure the vehicles are segregated.

NOTE TO READERS

Use of ‘must’ and ‘should’

These guidelines use ‘must’ and ‘should’ to indicate whether an action is required by law or is a recommended practice or approach.

TERM	DEFINITION
Must	Legal requirement that has to be complied with.
Should	Recommended practice or approach.

Key terms

In these guidelines we use the term ‘extractives operations’ as a general term to cover all three types of operations (opencast mining operations, alluvial mining operations and quarrying operations).

When specific information applies only to a particular type of operation, we will make that clear.

CONTENTS

PART A INTRODUCTION

1.0	About these guidelines	13
1.1	What are these guidelines about?	14
1.2	Who should read these guidelines?	15
1.3	What operations are covered by these guidelines?	15
1.4	What is an opencast mining operation?	15
1.5	What is an alluvial mining operation?	16
1.6	What is a quarrying operation?	16
1.7	Safety-critical roles and competency requirements	17

PART B RISK MANAGEMENT IN EXTRACTIVES

2.0	Health and safety management systems	20
2.1	Introduction to risk management	21
2.2	Health and safety management system (HSMS)	22
2.3	Identify hazards	23
2.4	Assess the risk	24
2.5	Manage the risk	24
2.6	What are principal hazard management plans (PHMP)?	25
2.7	What are principal control plans (PCP)?	26
2.8	Review control measures	26
2.9	Respond to reported hazards	26
2.10	Record keeping requirements	26
2.11	Notifications to WorkSafe	27
<hr/>		
3.0	Emergency management	31
3.1	What the law says	32
3.2	What the emergency plan needs to contain	32
3.3	Emergency plans for lone workers and small operations	33

3.4	Coordinated Incident Management System (CIMS)	34
3.5	Developing an emergency plan	35
3.6	Step 1: Assess potential emergencies	36
3.7	Step 2: Work out resources, people and skills required	36
3.8	Step 3: Develop the plan	37
3.9	Step 4: Test, practice and review the emergency plan	41

4.0 Managing work-related health **44**

4.1	What the law says	45
4.2	Managing work-related health risks	46
4.3	Worker health principal hazards and control plan	46

5.0 Hazardous substances **48**

5.1	How hazardous substances are classified	49
5.2	Control measures for managing hazardous substances	50

PART C **PLANNING AND DESIGN**

6.0 Planning safe excavations **52**

6.1	Introduction to planning safe excavations	53
6.2	Terminology	54
6.3	Identifying whether ground or strata instability is a principal hazard	55
6.4	Geotechnical assessments for mining operations, A-grade quarrying operations and A-grade alluvial mining operations	57
6.5	Geotechnical advice for B-grade operations	59
6.6	PHMP for ground or strata instability	59
6.7	Slope design	62
6.8	Ground support and reinforcement systems	67

7.0	Planning for tips, ponds, voids and dams	71
7.1	Identifying tips, ponds, voids and dams as principal hazards	72
7.2	PHMP for tips, ponds or voids	73
7.3	Planning and design criteria for tips	75
7.4	Planning and design criteria for ponds or dams	76
7.5	Construction of a tip or pond	77
7.6	Rehabilitation of tips	78

8.0	Planning for roads and other vehicle operating areas	79
8.1	Appraisal of roads and other vehicle operating areas	80
8.2	PHMP for roads and other vehicle operating areas	81
8.3	Design and layout of roads	81
8.4	Traffic management plan	102

PART D
MANAGING SAFETY RISKS FOR EXTRACTIVES OPERATIONS

9.0	Using explosives	106
9.1	Requirements for explosives	107
9.2	Hazard management and emergency planning for explosives	108
9.3	Maintaining, transporting and storing explosives	108
9.4	Shotfiring: safe systems of work	110
9.5	Explosives selection criteria	112
9.6	Drilling, charging and blasting	113
9.7	Firing	119
9.8	Post-firing	120
9.9	Misfires	122
9.10	Minimising blast damage	126

10.0 Controlling ground instability in excavations 127

- 10.1 Planning and design 128
- 10.2 Excavation rules 129
- 10.3 Excavation control and scaling 129
- 10.4 Slope movement monitoring programmes 132
- 10.5 Working near slopes 137
- 10.6 Remedial measures 138
- 10.7 Preventing falls from highwalls or faces 141
- 10.8 Historic underground workings 143

11.0 Tipping (or dumping) 145

- 11.1 Dumping and tipping methods 146
- 11.2 Controlling end-tipping risks 147
- 11.3 Suggested control measures 151
- 11.4 Procedures for examining tip heads 156
- 11.5 Tip maintenance and inspection 157
- 11.6 Other considerations for stockpiles 158
- 11.7 Reworking or reshaping tips 159

12.0 Extraction in and around water 160

- 12.1 Planning and design 161
- 12.2 Excavation procedures 161
- 12.3 Extracting beneath water 162
- 12.4 Floating plant and boats 163

13.0 Water or tailings storage in ponds and dams 169

- 13.1 Inspecting for signs of failure 170
- 13.2 Technical operational review 171
- 13.3 Cleaning out ponds and dams 172

14.0	Vehicles and traffic management	174
14.1	Public safety	176
14.2	Site access: contractors, visitors and public	178
14.3	Overhead power lines	179
14.4	Other overhead structures	180
14.5	Reversing, manoeuvring and parking	181
14.6	Loading vehicles	185
14.7	Loading and storage of large stone slabs or blocks	191
14.8	Feeding crushers	191
14.9	Railway sidings	192
14.10	Safe drivers and vehicles	192
14.11	Inspecting and servicing vehicles	199
14.12	Tyre safety	202
14.13	Maintenance and repair of roads	206

15.0	Plant and structures	207
15.1	Scope	208
15.2	Existing plant and structures	209
15.3	Identification and risk assessment of plant and equipment hazards	209
15.4	Mechanical or electrical management plan	210
15.5	Choosing, buying and upgrading plant and structures	210
15.6	Positioning of plant and structures	211
15.7	Access routes	211
15.8	Guarding	212
15.9	Guarding and maintenance	224
15.10	Conveyors	225
15.11	Emergency stops	226
15.12	Pre-start warning systems	227
15.13	Electricity	227

15.14	Cranes and lifting equipment	230
15.15	Maintenance of plant and structures	231
15.16	Common hazards when undertaking maintenance	232
15.17	Lockout and tagout processes	238
15.18	Permit to work systems	239

appendices

Appendix A: Glossary	242
Appendix B: References	251
Appendix C: Health and Safety at Work Act 2015 duties	254
Appendix D: So far as is reasonably practicable (section 22 of HSWA)	256
Appendix E: Working with other PCBUs – overlapping duties (section 34 of HSWA)	257
Appendix F: Worker engagement, participation and representation (Part 3 of HSWA)	258
Appendix G: Upstream duties (sections 39-43 of HSWA)	260

tables

1	Definition of soils and very weak rock	56
2	Definition of stronger rock	57
3	Key considerations for risk assessments for ground or strata instabilities	60
4	Example of FOS and POF design criteria approach	62
5	Artificial ground support measures	69
6	Recommended super-elevation	87
7	Recommended transition lengths	88
8	Typical friction coefficients for road pavements	93
9	Factors to consider during a blast risk assessment	111
10	Categories of damage to blasted sections	131
11	Maritime rules	164
12	Control measures for reversing options	181
13	Example of a Permit to Work (PTW) system	240

figures

1	Hierarchy of control measures	25
2	Example of an emergency station for an operation with a lone worker	34
3	What to consider when developing your emergency plan	35
4	Slope design terminology	54
5	Slope design – inter-ramp and overall slope details	54
6	‘Soils and very weak rock’ guidance	56
7	‘Stronger rock’ guidance	56
8	Development and maintenance of a ground or strata instability PHMP	61
9	Planar failure	63
10	Wedge failure	63
11	Step-path failure	64
12	Ravelling failure	64
13	Toppling failure	64
14	Circular failure	65
15	How to determine if tips (solid) are a principal hazard	73
16	How to determine if tips (liquid) and ponds are a principal hazard	73
17	Example of road layout with clearance between lanes	83
18	Turning arrangements	84
19	Segregation of light vehicles	85
20	Road gradient	85
21	Ratio to percentage grade conversion	86
22	Super-elevated bends	88
23	Sight distance	89
24	Road alignment	89
25	Intersection with restricted view	90
26	Intersection with improved visibility	91
27	Give way control selection	91
28	Stop control selection	91
29	Suitable windrow – firm material big enough to absorb the vehicle’s momentum with a steepened inside slope	95
30	Suitable windrow – the width of the windrow is as wide as the normal angle of repose	95
31	Windrow constructed on firm foundation	96
32	Suitable windrow – gaps in windrow for drainage	97
33	Unsuitable edge protection – blocks of stone can be pushed out of the way	97
34	Suitable edge protection – a rock with material in between which can safely absorb the impact	98
35	Runaway vehicle centre berm	99
36	Plan view – haul road escape lane	100
37	Profile view – haul road escape lane	100
38	Example of sign helping arriving drivers know what to expect	103
39	Example of weight restriction sign and narrow bridge sign	103
40	Face height should not exceed the reach of the loader used on the face	130
41	Face height should not exceed the reach of the excavator used on the face, with safe operating distances	130

42	Rock trap design	138
43	Example of a pedestrian windrow	141
44	Example of non-weight supportive barriers	141
45	Example of a fall restraint system	142
46	Example of tip slope stability design (limit equilibrium)	148
47	Example of dump construction method for mixed material (mattressing)	149
48	Example of dump construction method for competent material	149
49	Dumping sequence	150
50	Approaching tip point windrow	150
51	Vehicles should be parked on level ground (side to side) when dumping their load	152
52	Dump on level ground with a slight uphill gradient	152
53	Vehicle separation at tip point	154
54	Articulated vehicles	155
55	Cross section of stockpile	156
56	Dragline working beneath water	162
57	Long reach excavator working beneath water	162
58	Excavator working beneath water, loading floating plant	163
59	Example of gangway	164
60	Example of guardrails around a water pick-up station	165
61	Floating plant with drawbridge	165
62	Example of cleaning out a settling pond with an excavator	172
63	Examples of signage warning of hazards	177
64	Example of signage for small sites	177
65	Example of sign at gate	177
66	Example of pedestrian route	178
67	Safe working under power lines	179
68	Example of clearance signage and placement	180
69	Excavator with fitted guardrails to protect workers accessing the top of the machine for maintenance purposes	184
70	Haul truck with retrofitted stairway and platform to increase driver access and egress safety	185
71	This excavator has a good access system, with platforms, guardrails, kick plates and ladder – the ladder is interlocked so the vehicle cannot be started without the ladder being raised	185
72	Loading and restricted zones	186
73	Loads should be spread evenly across the vehicle	188
74	Cover loose bulk loads when travelling on a public road	188
75	Automated covering system	189
76	Manual covering system	189
77	Platform covering system	190
78	Overhead gantry harness system	190
79	Side-mounted mirrors	194
80	CCTV monitor in vehicle cabin	195
81	Example of fixed close-fitted guard enclosure on direct drive electric motors	212
82	Example of totally enclosing sheet metal guard, suitable for vibrating units with additional guards over the associated shafts and couplings	212

83	Example of panel mesh guards on fines dewaterer	212
84	Example of panel type guards on dryer	213
85	Example of close fitted guards on batch feeder belts	213
86	Example of close fitted guards on vee-belt drive	213
87	Example of a vee-belt with a fixed guard totally enclosing the drive	214
88	Example of hinged access panel guard bolted shut	214
89	Example of steel grid on elevated feed hopper	215
90	Example of steel grid on ground feed hopper	215
91	Plate type guard	217
92	Bottom idler nip guard	217
93	Example of head drum guards	218
94	Example of tail drum guard	218
95	Example of perimeter guarding on gravity take-up points	218
96	Example of skirting guards	219
97	Tail drum return nip guard	221
98	Head drum nip guard	221
99	Stone guillotine with fixed guards	222
100	Example of two-handed starting device and drop side extraction	222
101	Stone saw with gate at access points	223
102	Stone saw with light curtains at access points	223
103	Remote operation controls on stone saw	224
104	Example of remote greasing points	225
105	Emergency stop with signage	227
106	Flexible cords with tags	229

PART A

Introduction

IN THIS PART

This part helps you navigate and use the guide. It includes a definition of what types of mines and quarries this guide applies to and outlines the safety-critical roles and competency requirements for extractives operations.

1.0

About these guidelines

IN THIS SECTION:

- 1.1 What are these guidelines about?
- 1.2 Who should read these guidelines?
- 1.3 What operations are covered by these guidelines?
- 1.4 What is an opencast mining operation?
- 1.5 What is an alluvial mining operation?
- 1.6 What is a quarrying operation?
- 1.7 Safety-critical roles and competency requirements

Work at extractives operations can expose workers to many health and safety risks. These guidelines provide advice on how to manage common risks at extractives operations.

1.1 What are these guidelines about?

These guidelines can help persons conducting a business or undertaking (PCBUs) to meet their duties under the Health and Safety at Work Act 2015 (HSWA) and associated regulations. Mine operators and quarry operators are examples of PCBUs. In these guidelines PCBUs are referred to as 'you', unless otherwise specified.

The guidelines are grouped into five parts:

- Part A - Introduction
- Part B - Risk management in extractives
- Part C - Planning and design
- Part D - Managing safety risks for extractive operations
- Appendices.

These guidelines cover applicable requirements under the following legislation:

- [Health and Safety at Work Act 2015 \(HSWA\)](#)
- [Health and Safety at Work \(Mining Operations and Quarrying Operations\) Regulations 2016 \(the MOQO Regulations\)](#)
- [Health and Safety at Work \(General Risk and Workplace Management\) Regulations 2016 \(the GRWM Regulations\)](#)
- [Health and Safety at Work \(Worker Engagement, Participation, and Representation\) Regulations 2016](#)
- [Health and Safety at Work \(Hazardous Substances\) Regulations 2017 \(the Hazardous Substances Regulations\)](#)
- [Electricity \(Safety\) Regulations 2010](#)

Additional legislation applies in specific situations. See the References in Appendix B for a full list of the relevant acts, regulations and standards.

1.2 Who should read these guidelines?

These guidelines are mainly for:

- mine and quarry operators
- mine and quarry managers
- employers
- site health and safety representatives.

However, the guidelines may also be helpful for:

- workers
- contractors
- health and safety advisors
- consultants
- engineers.

The practices suggested in these guidelines provide principles to follow and examples.

The control measures required in a situation will depend on the extent and nature of the risks involved. High-risk situations require higher levels of control measures than low-risk situations. Examples given do not cover every possible situation and may not be relevant to all sites. You should complete your own risk assessments and take competent advice when implementing health and safety management systems.

Alternative methods may be used. These should be as safe, or better, than those set out within these guidelines.

1.3 What operations are covered by these guidelines?

These guidelines apply to opencast mines, alluvial mines and quarries (referred to in this guide as extractives operations). For full definitions for these types of operations, see Schedule 3 of HSWA and Regulation 3 of the MOQO Regulations.

If you are not sure whether your operations meets one of the definitions below, you should get legal advice.

1.4 What is an opencast mining operation?

There are two types of opencast mining operations:

- an **opencast coal mining operation**, which is any mining operation associated with the extraction of coal and where no person works underground
- an **opencast metalliferous mining operation**, which is any mining operation associated with the extraction of minerals and where no person works underground.

In these guidelines, these types are collectively called 'opencast mines'.

For the purpose of these guidelines, an opencast mine includes:

- all the workings when exploring for coal; or mining for coal or minerals
- all the surface extraction workings, including preparatory and abandonment works, associated with the opencast mine
- tips (or dumps), including stockpiles, associated with the opencast mine
- settling ponds or tailing dams associated with the opencast mine
- areas used for the processing of extracted materials (including crushing, screening, washing, drying, bagging and ore processing)
- the buildings and structures at the mine that are used for the working of the mine
- common areas (for example roadways and railways, but not public roads or railways under the control of a rail company)
- an opencast tourist mining operation.

1.5 What is an alluvial mining operation?

An alluvial mining operation is a mining operation carried out above ground associated with extracting:

- gold from river deposits of sand or gravel
- ironsand from sand or gravel.

If you extract and process other minerals found within ironsand deposits, this could mean that the operation is defined as a mining operation.

For the purpose of these guidelines, an alluvial mine includes the following:

- all the surface extraction workings including preparatory and abandoned works
- tips (or dumps) associated with and close to the site where the material is extracted
- working stockpiles associated with and close to the site where the material is extracted
- settling ponds or tailing dams associated with and close to the site where the material is extracted
- areas used for the preparation of extracted materials (including crushing, screening, washing, drying, bagging and ore processing)
- the buildings and structures at the mine that are used for the working of the mine
- common areas (for example roadways and railways, but not public roads or railways under the control of a rail company).

1.6 What is a quarrying operation?

A quarrying operation is an activity carried out above ground for:

- extracting any material (excluding coal or any mineral), from the earth, or
- for processing any material (excluding coal or any mineral) at the place where it was extracted or at a place adjacent to, or in the vicinity of, that place.

It includes the place where the extracting or processing is carried out.

To determine whether your operation is a quarry, ask:

- Do you extract material (excluding coal or minerals) from the earth?
- Do you process the material at the place it is extracted or another place nearby?

If you answered yes to either of these questions, it is a quarrying operation.

For the purposes of these guidelines, a quarry includes:

- all the surface extraction workings including preparatory and abandonment works
- tips (or dumps) at the place (or at a place nearby) where the material is extracted or processed
- working stockpiles at the place (or at a place nearby) where the material is extracted or processed
- settling ponds at the place (or at a place nearby) where the material is extracted or processed
- areas used for processing extracted materials (including washing, drying and bagging), where the processing is carried out at the place (or at a place nearby) where the extraction is undertaken
- the buildings and structures at the quarry used for the working of the quarry
- common areas (for example, quarry roadways and railways, but not public roads or railways under the control of a rail company)
- quarries in a forest, on a farm (see point below for when a farm is not a quarry) or on Crown or public land (for example, council reserves or riverbeds) regardless of whether the extraction is of an intermittent nature or not.

For the purpose of these guidelines, a quarry does not include:

- places on a farm where material is extracted or processed to be used on that farm, or
- areas where material is extracted, processed or moved for roading or other civil, commercial or residential construction projects at the place of the extraction.

1.7 Safety-critical roles and competency requirements

Workers in safety-critical roles must hold a current relevant certificate of competence (CoC) for their role at the operation. Being granted a certificate demonstrates their qualifications and experience for that role.

Opencast mines

RESPONSIBLE PERSON

The responsible person for a tourist mining operation, suspended mining operation or a coal exploration operation is the mine operator.

The responsible person for any other mining operation is the site senior executive (SSE).

SITE SENIOR EXECUTIVE

The mine operator must appoint a site senior executive (SSE). The SSE may be appointed to more than one mining operation if the mine operator has more than one. WorkSafe may advise that the SSE appointment is unsuitable for reasons outlined in Regulation 10 of the MOQO Regulations.

The mine operator must ensure the SSE has the resources and authority to carry out their duties.

The SSE must hold a CoC as a site senior executive. Their duties include:

- developing, implementing and maintaining the health and safety management system (HSMS) at the mining operation
- making sure a risk appraisal and risk assessment process is developed and used in the HSMS
- appointing other safety critical roles.

MINE MANAGER

The mine operator must appoint a person to:

- manage the mining operation, and
- supervise the health and safety aspects of a mining operation

Opencast coal mine managers must have an A-grade opencast coal mine manager CoC.

Metalliferous mine managers with:

- more than four workers (A-grade operation) who usually work at an opencast metalliferous mine, may hold a CoC as an A-grade quarry manager
- four or fewer workers (B-grade operation) who usually work at an opencast metalliferous mine, may hold a CoC as an A-grade quarry manager or a CoC as a B-grade quarry manager.

OTHER SAFETY CRITICAL ROLES

The SSE must appoint workers to carry out other safety critical roles including:

- mine surveyor
- supervisor.

Alluvial mines

RESPONSIBLE PERSON

The responsible person for an alluvial mine is the alluvial mine operator.

ALLUVIAL MINE MANAGER

The alluvial mine operator must appoint a person to:

- manage the alluvial mining operation, and
- supervise the health and safety aspects of the alluvial mining operation.

For an alluvial mine with more than four workers (A-grade operation), an alluvial mine manager must hold one of the following current, relevant CoCs:

- first-class mine manager, or
- A-grade alluvial mine manager, or
- A-grade quarry manager.

For an alluvial mine with four or fewer workers (B-grade operation), the manager must hold one of the following current, relevant CoCs:

- first-class mine manager, or
- A-grade alluvial mine manager, or
- A-grade quarry manager, or
- B-grade alluvial mine manager, or
- B-grade quarry manager.

Quarries

RESPONSIBLE PERSON

The responsible person for a quarry is the quarry operator.

QUARRY MANAGER

The quarry operator must appoint a person to:

- manage the quarry operation, and
- supervise the health and safety aspects of a quarrying operation.

For quarry managers with:

- more than four workers (A-grade operation) who usually work at their site, they must hold an A-grade quarry manager CoC
- four or fewer workers (B-grade operation) who usually work at their site, they must hold a minimum of a B-grade quarry manager CoC.

When counting the number of workers to determine which certificate is needed, only workers (including contractors) who are involved in extracting or processing materials are counted. Office workers, the manager and people transporting materials (for example truck drivers) from the site are excluded.

More information

For more information on the requirements and application process for each of the CoC types, see [New applications](#)

PART B

Risk management in extractives

IN THIS PART

This part of the guide introduces the principles of risk management and the Health and Safety Management System, and helps you identify hazards and assess risks. It also covers aspects of emergency management and work-related health as it applies to extractives operations.

2.0

Health and safety management systems

IN THIS SECTION:

- 2.1 Introduction to risk management
- 2.2 Health and safety management system (HSMS)
- 2.3 Identify hazards
- 2.4 Assess the risk
- 2.5 Manage the risk
- 2.6 What are principal hazard management plans (PHMP)?
- 2.7 What are principal control plans (PCP)?
- 2.8 Review control measures
- 2.9 Respond to reported hazards
- 2.10 Record keeping requirements
- 2.11 Notifications to WorkSafe

This section offers guidance for PCBUs on ways to apply good risk management principles in extractives operations.

2.1 Introduction to risk management

Risks to health and safety arise from people being exposed to a hazard (a source or cause of harm). Risk has two components – the likelihood that it will occur and the consequences (degree of harm) if it happens.

Under the Health and Safety at Work Act 2015 (HSWA), risks to health and safety must be eliminated so far as is reasonably practicable. If the risk cannot be eliminated, it must be minimised so far as is reasonably practicable.

'Reasonably practicable' means what is or was reasonably able to be done to ensure health and safety taking into account and weighing up relevant matters including:

- the likelihood of the risk concerned occurring or workers being exposed to the hazard
- the degree of harm that might result
- what the person concerned knows, or ought reasonably to know, about:
 - the hazard or risk
 - ways of eliminating or minimising the risk
- the availability and suitability of ways to eliminate or minimise the risk
- after assessing the extent of the risk and the available ways of eliminating or minimising the risk, the cost associated with available ways of eliminating or minimising the risk, including whether the cost is grossly disproportionate to the risk.

For more guidance read our fact sheet [Reasonably practicable](#) and see Appendix D.

Risk management is about:

- identifying hazards and assessing risks
- applying control measures to eliminate or minimise those risks
- regularly reviewing control measures.

You must engage with workers on health and safety matters that will – or are likely to – affect them and provide reasonable opportunities for workers to participate effectively in improving health and safety on an ongoing basis. For more information, see Appendix F.

If you are planning work that is likely to be done by contractors and subcontractors, consult with them where reasonably practicable, to clarify responsibilities and plan how to manage risks. For more information, see Appendix E.

2.2 Health and safety management system (HSMS)

All extractives operations must have a documented health and safety management system (HSMS) in place to help them keep workers and other persons safe.

This involves the development and use of processes to:

- identify hazards at the operation (systematic identification of hazards)
- assess the risk of harm from the identified hazards and identify the control measures required to manage that risk (risk assessment).

Workers must have reasonable opportunities to participate in developing and reviewing the development of the HSMS.

The responsible person must develop, document, implement and maintain the HSMS so that it complies with regulations.

Who is the responsible person?

- For a tourist mining operation, suspended mining operation or a coal exploration operation – **the mine operator**.
- For a quarry – **the quarry operator**.
- For an alluvial mine – **the alluvial mine operator**.
- For any other mining operation – **the site senior executive (SSE)**.

An HSMS must be in place for the whole duration of the operation. This includes from the start of the physical development of the operation and the construction of the infrastructure, including earthworks, until the operation is shut down.

The level of detail in the HSMS should match the type, size and complexity of the operation.

Content requirements for the health and safety management system

The HSMS must include:

- a health and safety policy
- processes for identifying hazards and the control measures required to manage the risk of harm to workers
- processes for the investigation of notifiable events
- a description of the systems, procedures, and other risk control measures in place to manage hazards and to respond to increased levels of risk (for example, shift reports)
- principal hazard management plans and principal control plans required for the operation (for more information, see Section 2.6)
- a description of arrangements to monitor the health and safety of workers
- arrangements for the monitoring, assessing and inspecting of workplaces.

For a complete list of minimum content required, see Regulation 56 of the MOQO Regulations.

2.3 Identify hazards

With your workers, identify hazards that could be associated with the work activity.

A hazard is a potential source or cause of harm. It could be an object, activity, event or even a person's behaviour.

Every work environment or work activity will be different. Looking at your work environment and thinking about things that could go wrong will help you to identify hazards.

To gather information, you could:

- have a look around your workplace, and observe workers while they work (for example, carry out safety observations and workplace inspections)
- look at your incident, accident and near miss registers, and the findings of your investigations into them
- ask your workers to help to identify hazards
- use qualified professionals to assist with analytical techniques for calculating the hazard (for example, geotechnical data for ground stability)
- use available guidance from WorkSafe or others (including industry representatives and membership organisations).

What is a principal hazard?

A principal hazard is any hazard that could create a risk of multiple fatalities in a single accident, or that could create a risk of multiple people being exposed to potentially fatal health risks.

Principal hazards in mining operations can include:

- ground or strata instability
- inundation and inrush of any substance
- mine shafts and winding systems
- roads and other vehicle operation areas
- tips, ponds, and voids
- air quality
- fire or explosion
- explosives
- gas outbursts
- spontaneous combustion in underground coal mining operations
- any other hazard that has been identified by the responsible person as a hazard that could create a risk of multiple deaths in a single event, or multiple people being exposed to potentially fatal health risks.

Principal hazards in A-grade quarrying operations and A-grade alluvial mining operations can include:

- ground or strata instability
- roads and other vehicle operating areas
- explosives
- any other hazard that has been identified by the responsible person as a hazard that could create a risk of multiple deaths in a single event, or multiple people being exposed to potentially fatal health risks.

The responsible person at a mining operation, A-grade quarrying operation and A-grade alluvial mining operation, must carry out an appraisal of the operation to identify principal hazards and ensure that there is a principal hazard management plan (PHMP) for each one identified. For information on what PHMPs are, see Section 2.6.

For any other hazards not considered principal hazards, use the general risk management process outlined in this section.

2.4 Assess the risk

You will need to carry out a risk assessment for each hazard you have identified. You should involve your workers in this process.

To identify and assess the risks arising from your work hazards think about:

- who might be exposed to the hazard
- what the potential consequences of exposure to the hazard are (for example, what severity of injuries or ill-health could result? Could people be killed or develop long-term health issues?)
- how likely the consequences are (for example very likely, likely or unlikely under usual business conditions).

When deciding which risks to deal with first, prioritise risks with potentially significant consequences such as serious injury or death, chronic ill-health, or those with a high likelihood of happening.

Some hazards that have exposure standards, such as noise and airborne contaminants, may need scientific testing or measurement. This is to accurately assess the risk and to check the relevant exposure standard is not being exceeded (for example, noise meters to measure noise levels and dust deposition meters to measure airborne dust).

2.5 Manage the risk

You must, so far as is reasonably practicable, eliminate risks to health and safety.

If elimination is not reasonably practicable, you must minimise those risks so far as is reasonably practicable.

The ways of managing risks are ranked from the highest level of protection and reliability to the lowest. This ranking is known as the hierarchy of control measures.

Using the hierarchy of control measures to manage risks will help you make sure you are using the most effective control measures first (see Figure 1).

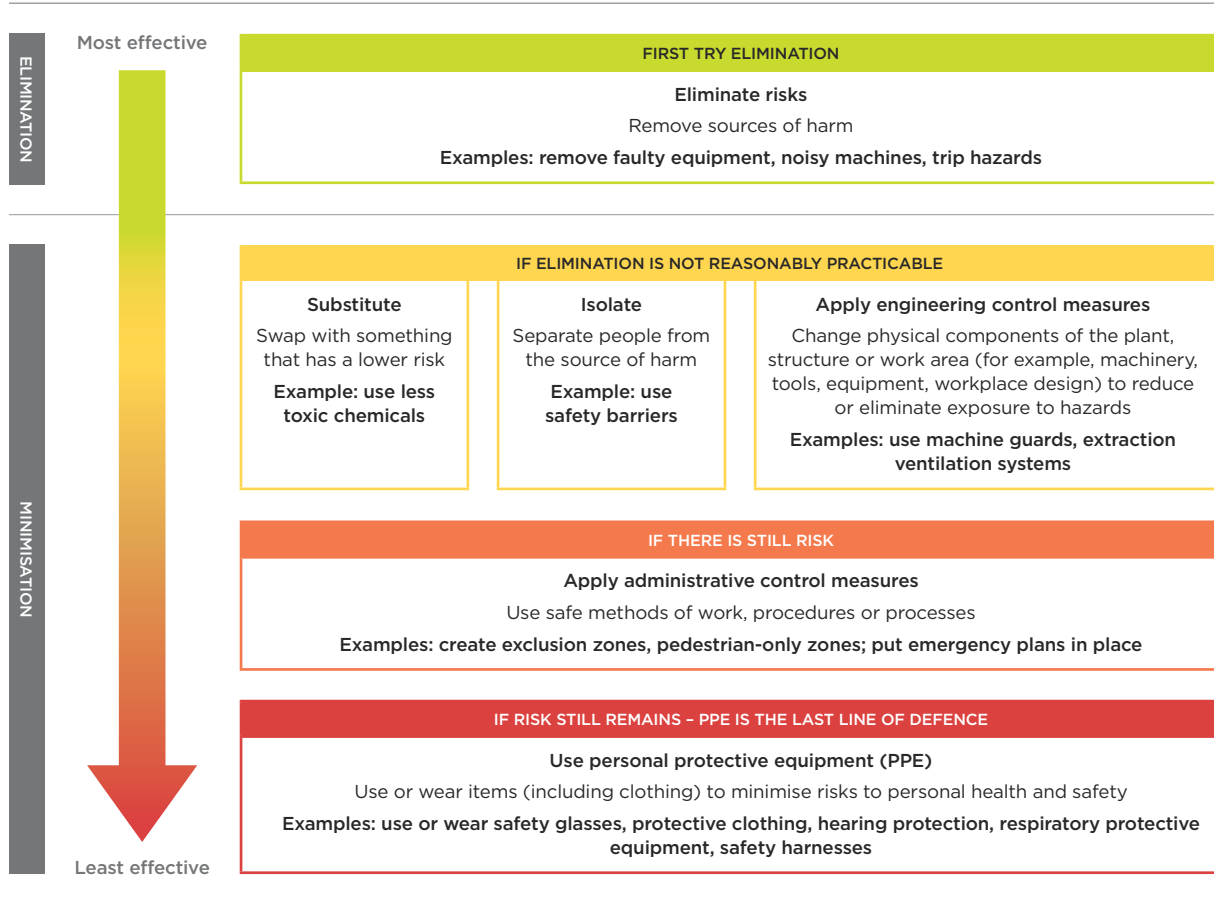

FIGURE 1: Hierarchy of control measures

You should use a combination of control measures. Using multiple control measures means that if a single control measure fails, there are other layers of protection for workers.

2.6 What are principal hazard management plans (PHMP)?

PHMPs apply only to mining operations, A-grade quarrying operations and A-grade alluvial mining operations, unless stated otherwise.

A PHMP sets out the measures that will be used to effectively manage each principal hazard identified. It should be documented and include:

- the nature of the principal hazard
- the roles, responsibilities, and competencies required to implement the PHMP
- any other matter required by the MOQO Regulations in relation to particular principal hazards.

It must also include a description of:

- how risk assessments will be conducted and the results
- the control measures to manage the hazard and the risk of harm it presents
- emergency preparedness
- the review and audit processes for the PHMP.

For a full list of requirements, see Regulation 68 of the MOQO Regulations.

2.7 What are principal control plans (PCP)?

A PCP explains the control measures, systems and processes in place to manage risks associated with more than one hazard. This may include principal hazards and other significant hazards, and the control measures that are applied to the whole operation.

If you do not have any principal hazards, you do not need a PCP.

If there are one or more principal hazards that apply to the mining operations, A-grade quarrying operations and A-grade alluvial mining operations, the responsible person must ensure there is a PCP that complies with managing that type of hazard or control. For example, if a principal hazard has been identified, you must have an emergency management PCP. If a principal hazard has been identified that could cause long-term health effects for workers, you must have a worker health PCP.

2.8 Review control measures

Control measures need to be regularly reviewed in consultation with your workers or their representatives, to make sure they remain effective. For more information on worker engagement, see Appendix F.

If there is a change in the workplace or work, check that your existing control measures are still the most appropriate ones to use.

There are also duties under the MOQO Regulations to audit and review control measures. Regulations 57-59, 69, 70, 75, 82, 89, 94, 95 of the MOQO Regulations outline the process of review and auditing for extractives operations.

For more information on general risk management, see our guidance [Managing risks](#)

2.9 Respond to reported hazards

If a worker reports a hazard, the relevant operator (mine, quarry or alluvial mine operator) must ensure:

- the reported hazard is investigated, and
- the worker who reported the hazard is advised of the result of the investigation.

Hazards include actions taken or not taken that conflict with any control measures in place. For example, not following documented procedures.

2.10 Record keeping requirements

All operations must keep certain records as a part of assessing and managing risks and tracking changes to the operation and past notifiable events.

Operation records

These must be kept at the site office and available for workers, and in the case of mining operations, the SSE, to inspect at any time. There is information that must be included, for example records of CoCs and other training records, statutory notices from WorkSafe and the PCBU's responses, and results of operation examinations (workplace inspections).

For a complete list of required operation records and requirements, see Regulation 219 of the MOQO Regulations.

Shift reports

A written report must be completed that includes:

- the current state of the workings and plant at the operation
- material matters, related to work done during the shift, that may affect the health and safety of workers
- issues and hazards identified during the shift
- any control measures implemented.

For a mining operation, the report must be written by the person appointed to be supervisor under Regulation 31 of the MOQO Regulations.

For quarrying and alluvial mining operations, the report must be written by the person supervising the relevant shift.

The shift report must be communicated to the person supervising the incoming shift and the workers on the incoming shift.

The procedure for writing and communicating the shift reports must be included in the HSMS.

For more information, see Regulation 221 of the MOQO Regulations.

Examination of operation

The site must be examined before the start of each working shift and at suitable times during the shift, in areas where workers are or will be present. Every accessible area of the operation (including vehicles) must be examined at least once a week.

Examinations must be carried out by a competent person to help manage potential hazards and prevent harm.

There must be a written procedure for conducting these examinations included in the HSMS, and it must include:

- matters to be covered by the examination
- a timetable for carrying out examinations
- the process for recording findings
- the process for taking action as a result of findings.

For more information, see Regulation 222 of the MOQO Regulations.

Who is a competent person?

A competent person means a person who has the knowledge, experience and skills to carry out a particular task under the MOQO Regulations and has a relevant qualification or (in the case of employees) certificate from the employer showing this.

2.11 Notifications to WorkSafe

The relevant operator (the mine, quarry or alluvial mine operator) must ensure WorkSafe is notified of:

- the commencement, recommencement, installation, suspension or abandonment of the operation
- any of the notifiable events set out in Schedule 5 of the MOQO Regulations
- any of the high-risk activities set out in Schedule 7 of the MOQO Regulations.

The relevant operator must:

- ensure written notice of the appointment of a manager or acting manager, are given to WorkSafe

- notify WorkSafe about certain events (for example, commencement of operations) a specified length of time before the proposed date it happens
- provide quarterly reports on the information listed in Schedule 8 of the MOGO Regulations.

Minimum time required for notifications

The mine operator must give written notice to WorkSafe of the appointment of an SSE and make sure that written notice of the appointment of an acting SSE is given to WorkSafe.

Commencement – new site

For new operations, notification of commencement must be given no later than 2 months before the proposed date of commencement.

Definition of commencement

Commencement refers to the start of specific activities for different types of operations, as defined in HSWA. Here is what it means for different types of operations:

Mining operations: beginning one or more of the activities listed in clause 2(a) and (b) of Schedule 3 of HSWA.

Quarrying operations: beginning one or more of the activities listed in clause 3(1)(a) of Schedule 3 of HSWA.

Tunnelling operations: starting to extract material with the purpose of creating, enlarging, or extending a tunnel or shaft.

Alluvial mining operations: beginning one or more of the activities described in paragraphs (a) and (b) of the definition of 'alluvial mining operation' in clause 1 of Schedule 3 of HSWA.

Some operations, which will only operate intermittently, may notify WorkSafe no later than 24 hours before the proposed date of commencement.

Operations that have not yet commenced must give PHMPs and PCPs to WorkSafe

Operators of mining operations and A-grade operations that have not yet commenced, must give all PHMPs and all PCPs for the operation to WorkSafe at least two months before they commence.

There are exceptions to this requirement.

- If the quarry operator at an A-grade quarrying operation changes, the new quarry operator must submit the documents to WorkSafe at least 14 days before they commence.
- If a quarrying operation is being worked on a short-term basis by using mobile crushing units and the quarry operator has already provided the documents to WorkSafe, they can be submitted one week before the operation commences.
- If an A-grade quarry needs to begin operating at very short notice as part of an emergency response to help preserve life or critical infrastructure, the quarry operator must submit the documents to WorkSafe as soon as possible after the need for the quarrying operation arises.

If you are unsure of the requirements you must meet, check with WorkSafe by emailing hhu.extractives@worksafe.govt.nz

New operator for an existing site

The new operator must notify WorkSafe about the change of operator for all sites. They must also notify WorkSafe about the safety-critical roles for the operation.

Suspension

When operators plan to suspend a site, the notification period depends on how long the site has been operating.

Definition of suspension

Suspended refers to operations that are temporarily not carrying out certain activities but have not been abandoned. Here is what it means for different types of operations:

- **Mining operations (excluding tunnelling):** maintenance work may still be happening to ensure the operation can resume activities in the future (such as those listed in clause 2(a) and (b) of Schedule 3 of HSWA) or while the operation is winding down in preparation for abandonment, but:
 - the activities listed in clause 2(a) and (b) of Schedule 3 of HSWA (other than maintenance) are not being carried out for the time being, and
 - the mining operation has not been abandoned.
- **Tunnelling operations:** tunnelling activities are not currently being carried out, but the operation has not been abandoned.
- **Quarrying operations:** the activities listed in clause 3(1)(a) of Schedule 3 of HSWA are not currently being carried out, but the quarrying operation has not been abandoned.
- **Alluvial mining operations:** alluvial mining activities are not currently being carried out, but the operation has not been abandoned.

For an operation that has been operating for fewer than 12 months, WorkSafe must be notified at least 24 hours before the proposed date of suspension.

If the site has been operating for more than 12 months, WorkSafe must be notified at least 14 days before the proposed date of suspension.

However, quarry operators are not required to notify WorkSafe of the proposed date of suspension until:

- the operator knows that the quarrying operation will be suspended for 6 months or more, or
- the operation has been suspended for 6 months.

Operations that are not suspended must undertake statutory inspections and other regulatory requirements, such as quarterly reporting.

Recommencement

If operations have notified WorkSafe of suspension, WorkSafe must be notified at least 14 days before recommencing if:

- mining operations have not operated in the last two months before the proposed recommencement date, or
- quarrying operations or alluvial mine operations have not operated in the last six months before the proposed recommencement date.

Abandonment

For an operation that has been operating for fewer than 12 months, WorkSafe must be notified at least 24 hours before the proposed date of abandonment.

If the site has been operating for more than 12 months, WorkSafe must be notified at least 14 days before the proposed date of abandonment.

Quarterly reporting

Reports must be given to WorkSafe for each quarter of every year, beginning on 1 January, 1 April, 1 July, and 1 October. Reports should be submitted in the first month of the new quarter.

If a new operation commences in November, they need to submit their first report in January. This report will be on the time they worked in the previous quarter – in this example, for November and December.

The report must include information about the operation, workers, and any injuries. For a complete list of information to include, see Schedule 8 of the MOQO Regulations.

For more information, see Regulation 230 of the MOQO Regulations.

Notifiable events

Extractives operations must report any notifiable events. This includes the death of a person, injuries, illnesses, and incidents to do with:

- ground, geotechnical and structural failures
- emergency, escape and rescue
- vehicles and plant
- shotfiring
- electricity.

For more information on what needs to be notified for extractives operations, see Schedule 5 of the MOQO Regulations.

For examples of other notifiable events, see our guidance [What events need to be notified?](#)

Records of every notifiable event at the operation must be kept, including incidents where emergency, escape and rescue are needed.

For more information on what needs to be included in records, see Schedule 6 of the MOQO Regulations.

Investigation findings for notifiable events

Reports of any investigation findings must be provided to WorkSafe within 30 days after the date of the notifiable event.

3.0

Emergency management

IN THIS SECTION:

- 3.1 What the law says
- 3.2 What the emergency plan needs to contain
- 3.3 Emergency plans for lone workers and small operations
- 3.4 Coordinated Incident Management System (CIMS)
- 3.5 Developing an emergency plan
- 3.6 Step 1: Assess potential emergencies
- 3.7 Step 2: Work out resources, people and skills required
- 3.8 Step 3: Develop the plan
- 3.9 Step 4: Test, practice and review the emergency plan

Emergencies occur when control measures for risks fail, putting workers or other people at an immediate risk of harm.

3.1 What the law says

All PCBUs must have an emergency plan

Under the Health and Safety at Work (General Risk and Workplace Management) Regulations 2016 (GRWM Regulations), all PCBUs must ensure that an emergency plan is prepared for the workplace. For general information on what to include in an emergency plan see Section 8.0 of our guidance [General risk and workplace management – part 1](#)

All extractives operations have specific duties relating to emergencies.

Regulations 124 to 126 of the MOQO Regulations lists specific duties all extractives operations must have in place even if they do not have a principal hazard and do not need an emergency management principal control plan (PCP).

Emergency management principal control plans

Under the MOQO Regulations, mining operations, A-grade quarrying operations and A-grade alluvial mining operations that identify one or more principal hazards at their site must have an emergency management PCP. Section 3.5 of these guidelines describes the minimum requirements that should be addressed in the plan. See Regulation 105 of the MOQO Regulations for the full requirements.

Note: Other regulations have additional or separate requirements for emergency plans (for example, the Hazardous Substances Regulations). For more information on emergency management, see our guidance [Your practical guide to working safely with hazardous substances](#)

3.2 What the emergency plan needs to contain

Emergency plans must include the following:

- Emergency procedures including:
 - an effective response to an emergency
 - evacuation procedures
 - procedures for notifying emergency services at the earliest opportunity
 - medical treatment and assistance procedures
 - procedures to ensure effective communication between the person authorised by the PCBU to coordinate the emergency response and all other persons at the workplace.

- The testing of the emergency procedures, including the frequency of testing.
- The information, training, and instruction to be given to relevant workers in relation to implementing the emergency procedures.

When working out how to do this, you must consider all relevant matters including the:

- size and location of the operation
- number and composition of the workers
- nature of the work being carried out and the hazards
- views of workers.

When thinking about what emergency procedures should be included in the emergency plan, consider the types of emergency situations the operation may face, for example, fire or natural disasters.

3.3 Emergency plans for lone workers and small operations

A PCBU must manage risks to the health and safety of remote or isolated workers. Small operations and lone workers have different emergency needs than larger operations. There may not be enough people on site with the worker or nearby to the work to respond to an emergency. Advance planning and preparation is very important for lone workers.

Consider the following steps when determining first response for the site:

1. Notifying emergency services of your location and how to get in.
2. Share your GPS location with emergency services.
3. Make sure you have a way to communicate.
4. Keep your first aid training up to date and have enough first aid supplies.
5. Mark a safe area where a helicopter can land.
6. Provide a list of important phone numbers for emergency help.

For lone workers, no one will be there to call for help if you are injured or trapped. If there is no service for mobile phones, carry a personal locator beacon. This can send a distress signal to emergency services.

It may take longer for help to arrive when using a personal locator beacon, so good risk management is critical.

See Figure 2 for an example of an operation with a lone worker. They have:

- an emergency station set up with a first aid kit and buoyancy aid
- located it where emergency services can easily see it when they arrive
- equipment needed for responding to the immediate risks - it is not kept in the digger
- a personal locator beacon with them.

For the size and scope of this operation, the emergency station is fit for purpose.

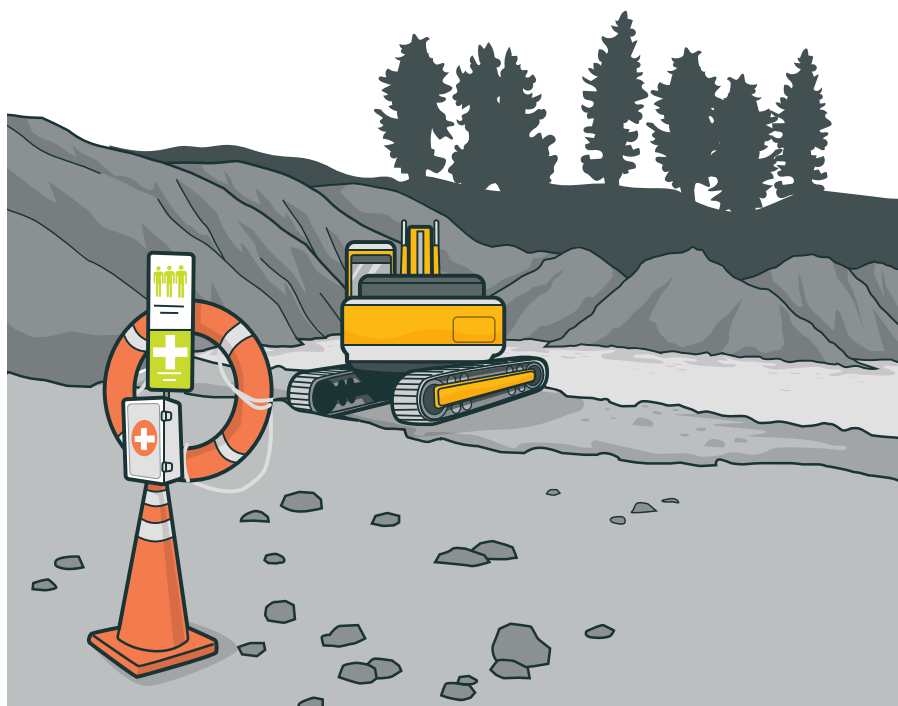

FIGURE 2:
Example of an
emergency station
for an operation
with a lone worker

3.4 Coordinated Incident Management System (CIMS)

Sometimes, emergencies can escalate from a minor, site level incident to requiring a large multi-agency emergency response. At other times, the incident may be so serious that a large multi-agency response is required immediately. A large response uses the Coordinated Incident Management System (CIMS). This system is best supported when operators base their entire emergency management plan on this system.

CIMS is an emergency response system that describes:

- how emergency agencies coordinate, command and control their response to an incident of any scale
- how the response can be structured
- the relationships between the respective CIMS functions
- the relationships between the levels of response.

CIMS can expand or shrink to fit any type of emergency. However, it is easier for CIMS to support large scale emergencies when the fundamental principles are used in the emergency management plan. For more information on the principles of CIMS, see the National Emergency Management Agency webpage [Coordinated Incident Management System \(CIMS\) third edition](#)

3.5 Developing an emergency plan

Below are things to consider when developing an emergency plan (see Figure 3). Sections 3.6 to 3.9 provide more detail of each step.

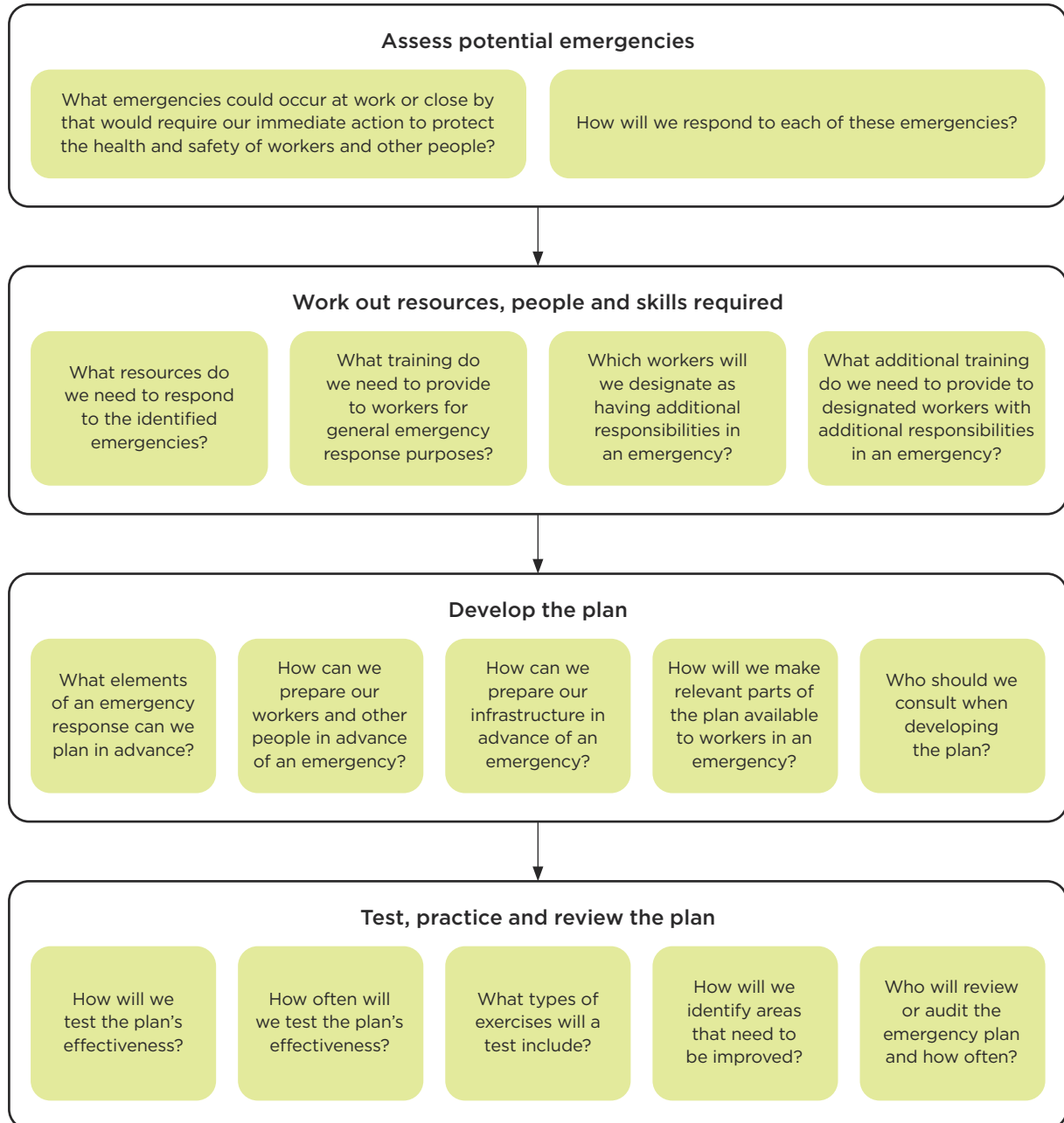

FIGURE 3: What to consider when developing an emergency plan

3.6 Step 1: Assess potential emergencies

To do this, identify hazards on or near the site. This includes environmental risks such as bushfires near forested areas or flooding near rivers. Hazards can also be identified in past risk assessments or incident reports.

Then consider the worst-case scenario for each hazard as well as who could be affected and how you would respond to prevent or minimise damage. If the control measures for the hazard fail, and urgent action is needed to protect the health and safety of workers or other people, you must have an emergency plan for that hazard.

If principal hazards have been identified, an emergency management PCP must be developed in line with the MOQO Regulations, see Section 3.5 for more information.

3.7 Step 2: Work out resources, people and skills required

After you have identified possible emergencies and how to respond to them, the next step is to work out what is needed to make those responses work. This includes deciding what equipment and facilities are required, what specific people or roles need to do in each emergency and making sure the people are trained to do it.

Consider what resources you need to respond to emergencies

Resources include:

- the equipment needed to respond to emergencies, such as fire extinguishers, lifting equipment or first aid equipment
- the written material that should be provided to workers, such as procedures and duty cards
- the people that will be needed including emergency services
- for operations with principal hazards, the infrastructure that will be necessary to carry out a full scale, multi-agency response.

Consider who needs to have a specific role or job during an emergency

The most common emergency role is providing first aid. In smaller operations, this might be a trained first aider. In larger operations, it could be a more qualified medic, such as a paramedic or someone trained in pre-hospital emergency care. A PCBU must ensure that an adequate number of workers are trained to give first aid at the workplace. In small operations, a worker with a workplace first aid certificate may be enough.

If your operation has a principal hazard (and therefore must have an emergency management PCP), your plan must include training for workers in firefighting.

You should have someone responsible for making sure all workers are evacuated and accounted for.

Think about assigning people to:

- communicate with emergency services until they arrive
- secure the site and stop the public from entering
- talk to workers' families.

In large-scale emergencies, especially if emergency services are far away, you may also need incident controllers or other trained experts to start a CIMS-based emergency response before emergency services arrive.

Consider what training workers and visitors will need for emergencies

Once you have worked out what roles and equipment are needed for an emergency response, the next step is making sure the right people are trained. This is essential for making sure your emergency plan works.

A good rule to follow is that if a worker needs to know something for an emergency that is not part of their usual job, they will need training. For example:

- a first aider must be trained in first aid
- a worker in an area with fire extinguishers for first response must know how to use them
- an incident controller or specialist who gives advice to emergency services should have CIMS training
- a lone worker might need training in how to properly use a personal locator beacon.

Some training can be informal. For instance, showing workers:

- how to secure the site quickly and safely
- who to let onto the site during an emergency
- how to raise the alarm when there is an emergency
- what information needs to be provided to emergency services during a 111 call.

You should induct regular visitors such as inspectors, contractors, couriers and delivery workers, so that they understand the hazards on site.

3.8 Step 3: Develop the plan

Once you have worked out the key parts of your emergency plan, the next step is to bring everything together into a formal emergency plan.

Involve workers and emergency services in planning

Workers should always be consulted when developing an emergency plan. Frontline workers often know the risks best and can offer valuable insights to help shape the plan.

If principal hazards are identified at your site you must consult with emergency services, this includes the fire, police and ambulance services for the area where your operation is located. It is still good practice to consult with emergency services even if you do not have principal hazards. It is also good practice to consult the New Zealand Mines Rescue Service.

Talking with emergency services early helps with planning. For example, they will learn:

- that your operation is in the area
- what hazards are on site
- what emergency response capability you have
- your GPS location
- where there is mobile phone coverage.

These conversations mean a lot of planning is already done before an emergency happens. Emergency services may also suggest other steps to take.

What elements of an emergency response can be planned?

Most emergency responses can and should be planned. Regulation 105(1) of the MOQO Regulations provides minimum requirements for an emergency management PCP, this is described below.

COORDINATION AND CONTROL

The plan should clearly state who is in charge during an emergency – usually the manager. There should be backups in case key people are unavailable. The plan should align with CIMS principles for larger-scale emergencies and outline what additional resources may be needed.

ROLES AND RESPONSIBILITIES

Identify roles or positions responsible for:

- coordinating the response and contacting emergency personnel
- accounting for people on site
- managing emergency supplies and facilities
- providing transport for casualties and emergency workers
- operating communication systems
- communicating with workers, families, regulators and media
- fire wardens and site emergency teams.

These responsibilities will vary depending on site risks.

EMERGENCY SERVICES

Include details for contacting all relevant emergency services. List phone numbers and organisation roles (not individual names unless regularly updated). Consider travel times and response delays.

THE EVENTS THAT TRIGGER THE ACTIVATION OF THE PLAN

List events that trigger activation, for example, fire, medical emergency or rock fall. Workers should be trained and empowered to activate the plan immediately – it is better to have a false alarm than delay.

COMMUNICATION SYSTEMS IN EMERGENCIES

Outline how communications will be used, including:

- clearing radio channels
- ending all non-essential calls
- using backup devices such as satellite phones and police communication systems.

It is important to have a plan for how you will communicate the emergency to all workers and others on site.

Reliable communication is vital, especially for remote or lone workers. Ensure communication systems are suitable for the environment (for example, do not use mobile phones where flammables or explosives are present. They are a potential ignition source.)

GIVING TIMELY NOTICE, INFORMATION AND WARNINGS TO ANYONE AFFECTED

Have systems for:

- notifying next of kin and emergency contacts
- contacting neighbouring properties
- sharing status updates.

Emergency contact details for all workers must be kept up to date.

ISOLATING THE AREA

Pre-plan how to isolate the emergency area, for example using barriers to block access or fire breaks to prevent fires from spreading.

ACCOUNTING FOR PEOPLE

Have a reliable system to account for all workers and visitors (for example, sign-in registers, tag boards or radio frequency identification (RFID) tags). Choose methods based on the size of the operation or site, working times and shifts and the risks that may be present.

EVACUATION

Define when and how to evacuate. This may include self-escape, aided escape or rescue. Also include evacuation triggers (for example, smoke alarms or ground movement) and the risks people may face when escaping.

TRANSPORT

Plan how to move all people, including casualties and visitors, to a safe area. Do not rely solely on walking.

FIRST AID

Identify and prepare suitable equipment, facilities and trained first aiders. For more information on how to do this, see our guidance [First aid at work](#)

FIREFIGHTING

Make sure everything needed to effectively fight fires is in place. This can include procedures, training and suitable equipment (for example, fire extinguishers for fuel fires in vehicles).

WORKER TRAINING AND PROCEDURES

Any part of the plan requiring worker action should have clear procedures. Workers must be trained in the emergency management PCP and a record of this training should be kept.

EMERGENCY EQUIPMENT

Provide equipment based on likely emergencies, site layout, and distance from emergency services. Examples include:

- breathing apparatus (for confined space entry)
- ropes
- ladders (rigid or rope)
- tripods, winches
- tools (such as pickaxe, crowbar, shovel, cutters)
- stretchers and blankets
- buoyancy aids (lifejackets or lifebuoys)
- rescue boats
- chemical spill kit
- fire extinguishers
- fire hose reels
- bush fire kits
- first aid supplies
- self-rescuers
- a mobile generator to power emergency lighting
- lifting and cutting equipment such as hydraulic props, hardwood wedges in various sizes, lifting bags and cylinders, pneumatic pick
- resuscitation equipment
- defibrillator
- detachable personnel basket for large earthmoving equipment

- lifting hoops
- a sanitary area designated for the provision of first aid, such as a first aid room.

ESCAPE ROUTES

Design workplaces with escape in mind. Mobile plant should have alternative exits such as purpose-built hatches or windows that can be easily removed or broken. Fire extinguishers should be fitted where there is a risk of fire.

SITE ACCESS

So far as is reasonably practicable you should maintain roads into and within the workplace. Provide enough space for multiple fire appliances. Assign someone to meet emergency services at the entrance.

HELICOPTER ACCESS

For remote sites, so far as is reasonably practicable, plan a suitable landing area and inform emergency services in advance.

Important

Have a back-up plan. For example, if a fire suppression system fails, use an extinguisher and if that fails, withdraw workers and let the fire burn out safely.

When developing procedures, you should always ask the question 'if it fails, then what?'.

How will workers access the plan during an emergency?

Emergency response and evacuation plans should be easy to access and use in any emergency. These plans should explain clearly what actions to take and in what order. They should be written in everyday language and easy to follow under pressure.

Some parts of the plan can be displayed as signs or bullet point lists near key areas, like doorways or places where fast action is needed. Use checklists to show the steps to take, in the order they must be taken. Any signage must be clearly visible and easy to read and understand. Make sure they are available to the people who need to use them. You can do this by:

- setting up a dedicated emergency area that holds all emergency procedures and rescue gear (except equipment fixed in specific locations)
- keeping duplicates of instructions and equipment close to where people may need to act quickly.

For large operations

Use Trigger Action Response Plans (TARPs) – these help guide decisions and actions when certain triggers occur.

For small operations

You can use an [emergency response plan flipchart](#)

This is a set of easy-to-use forms that help identify and manage emergency procedures.

Most workers only need to know how to evacuate safely and go to the designated safe area. PCBUs should make sure workers know what to do if there is an emergency. This should be part of training at all operations, including inductions for workers and visitors.

How can you prepare the operation's infrastructure for an emergency?

Getting the site ready for emergencies is part of planning ahead. Below are some ways to prepare the site.

Create a designated emergency station. This should hold all emergency procedures and equipment and be easy for workers and emergency services to find when they arrive.

Place equipment where it is needed. For example, fire extinguishers should be inside trucks, on barges or in other key areas.

Put extra copies of emergency procedures near high-risk areas where they may be needed in a hurry.

Work with the police

When preparing for a large-scale emergency, police may recommend having:

- a room for about 15 people
- good communication systems
- plenty of whiteboard space.

This space is known as the incident control point. If the site is too small to have this kind of room, follow the advice given by police and adapt where possible.

Map the site

A site map should show:

- the outer perimeter which marks the boundary of the site
- the inner perimeter which marks out the hazardous area that only trained rescue teams should enter
- the safe forward point which is the closest point to the hazard that is safe for others to reach
- the staging area which is where emergency services gather and are briefed. This should be between the inner and outer perimeters and not too close to the incident control point, so it does not disrupt the emergency response team.

Emergency equipment and signage

First aid equipment should be placed in easy to reach locations and marked on the site map. Use clear signs to show where specific emergency items are kept (for example, where to find a defibrillator).

3.9 Step 4: Test, practice and review the emergency plan

An emergency plan is not effective until it has been tested. Practice drills (scenario training) help confirm the plan works and gives workers the chance to practice. Once the plan is working well, regular practice is still important.

You should also review the plan when:

- it has been tested and practiced
- new hazards are found
- an emergency happens on site, and
- as part of an annual audit.

How will the emergency plan be tested?

The emergency plan must be tested regularly with practice drills, and these must involve emergency services. This helps identify gaps in training or the plan itself, and checks that the plan actually works.

Test every part of the plan. For larger operations this includes:

- notifying families
- accounting for all people on site
- letting managers know about the emergency (on and off site).

If something in the plan does not work, update it and test it again in the next drill.

Practice drills should be based on real hazards from your operation and should consider how emergencies can develop and change over time.

How often should drills happen, and what types are needed?

The responsible person must ensure workers are trained in the emergency management plan and that this training is recorded.

Practice drills are essential for everyone – including contractors. For short-term contractors or visitors, a lighter training option may be appropriate, but they should always be accompanied by someone with appropriate emergency training.

Drills should happen at least every three months. This helps build confidence and automatic responses in an emergency.

There should be a mix of planned drills for training and surprise drills to simulate real experience.

Focus more often on the most likely and most dangerous emergencies.

Some parts of the plan should be included in every drill, such as contacting all managers (on and off site) and accounting for everyone on site.

How will improvements be identified?

No emergency plan is perfect. There will always be things to improve.

After each drill, hold a debrief so workers and managers can share what went well and what did not. Observers from emergency services, where present, can also provide feedback.

If something goes wrong during a drill or an emergency response, consult with your workers and, together, identify areas for improvement. The problem might be:

- a procedure not being clear and easy to follow
- equipment being unavailable or in the wrong place
- inadequate training.

Finding and fixing these issues helps make the plan better and more effective in future emergencies.

Who will review or audit the plan, and how often?

Emergency plans should be reviewed and updated regularly (at least once a year) so they remains effective.

For emergency management PCPs for mining, A-grade quarrying and A-grade alluvial mining operations, the responsible person must review the plan every two years and if any of the following happen:

- there is an accident involving a hazard that the PCP was intended to manage
- there is a major change in how the operation is managed that could affect the PCP
- there is a major change to the equipment or machinery used that could affect the PCP
- something else happens that the PCP identifies as needing a review.

The PCP must be audited every three years by a competent person who is independent of the mining operation.

If the plan changes significantly, emergency services may need to be consulted again.

Knowing and using your emergency plan can save lives – including your own.

4.0

Managing work-related health

IN THIS SECTION:

- 4.1 What the law says
- 4.2 Managing work-related health risks
- 4.3 Worker health principal hazards and control plan

Work can affect health, just as health can affect a worker's ability to work safely.

All extractives operations should have a worker health control plan in place that describes how worker health risks are managed for the site. See *What to include in your worker health PCP* in Section 4.3 for a list of things to consider.

The hazards in the list are specific to worker health PCPs but can be useful for all extractives operations to consider when developing their own worker health control plans.

A-grade operations and mining operations may be required to have a worker health PCP if they have identified one or more principal hazards at the operation that could have long-term effects on worker health. See Section 4.3 for more information on this.

4.1 What the law says

Under GRWM Regulations PCBUs must manage health risks in the workplace

Under Part 1 (general duties) PCBUs must:

- identify hazards that may be a risk to the health and safety of workers (and other people)
- ensure that effective control measures are set up to eliminate risks so far as is reasonably practicable, or where elimination is not reasonably practicable, implement control measures to minimise risks to health and safety. These control measures must be maintained so that they remain effective.

Under Part 2 (management of particular risks) PCBUs must:

- ensure that health monitoring is provided to workers who carry out work involving substances hazardous to health.

Duties to provide health monitoring for workers under the MOQO Regulations

Medical examinations must be offered to each worker:

- immediately before the worker starts work at the mining operation
- immediately before the worker ceases working at the operation, if the worker has not been examined within the 12 months before that date
- periodically throughout the time that the worker is working at the operation, but no less than once every five years.

You must also ensure:

- if a worker wishes to be examined, that they are examined at your operation's expense by a medical practitioner or nurse chosen after consultation with the worker
- every worker is given all results of monitoring of their health

- all workers are given results of general monitoring of conditions at the operation or the health or safety of workers there
- records of the monitoring are made available to WorkSafe on request (make sure that no record identifies or discloses anything about any individual worker except with their consent)
- records of the monitoring are kept for any hazard the worker may have been exposed to that is known to have a cumulative or delayed effect, for at least 30 years
- for all other hazards, records of the monitoring are kept for at least seven years after the record is made or until the worker stops working at the operation
- records of first aid provided to workers who are seriously injured at the operation are kept for at least seven years after the date of the incident.

For more information on health monitoring as well as exposure monitoring, see Section 4.0 of our guidance [Managing health risks in the extractives industry](#)

4.2 Managing work-related health risks

There are a range of risks at work that can affect a worker's health. These include physical, chemical, biological, ergonomic and psychosocial risks.

When managing work-related health risks you must follow the general risk management process of identifying hazards, assessing the risk, implementing control measures and reviewing control measures. You must also make sure that workers' health is monitored to prevent injury or illness from work. For more detailed information on doing this, see Section 3.0 of our guidance [Managing health risks in the extractives industry](#)

4.3 Worker health principal hazards and control plan

Identifying principal hazards with long-term health effects

To find out if there are principal hazards that may have long-term effects on a worker's health, or the health of a group of workers, look at the different situations they may be exposed to. This includes but is not limited to:

- materials, substance or fumes workers might be exposed to and what the consequences of exposure could be (for example, coal dust, silica dust, diesel particulates, welding fumes and chemicals)
- types of work being done and where it is being done (for example, working outdoors, working in extreme temperatures or doing physical tasks such as manual handling)
- equipment and tools being used and how workers interact with them (for example exposure to noise or vibration)
- how long workers are exposed to potentially hazardous material, fumes, substances or situations
- hours of work (including travel time to and from sites, and shift work) and fatigue
- individual workload
- the possible effects of drugs or alcohol on a worker's ability to stay healthy and safe at work.

What to include in your worker health PCP

The worker health PCP must, at a minimum, address how the following hazards are to be monitored and controlled where they are present at the operation:

- [noise](#)
- [vibration](#)
- [dust](#) - including asbestos dust, coal dust, silica dust or mixed dust (being dust that contains mixtures of more than one different kind of dust)
- diesel particulates
- [fumes](#) - including exhaust fumes, welding fumes, and other fumes arising from metallic sources
- [temperature](#) - including extreme hot and cold temperatures and humidity
- changes in atmospheric pressure
- [manual handling and lifting](#)
- hours of work and [fatigue](#)
- [psychosocial hazards](#)
- [ultraviolet radiation](#)
- ionising radiation
- biological hazards
- any other hazard that may adversely affect the health of workers who work at the operation.

For examples of how to identify these hazards and manage the risks at an extractives operation, see our guidance [Managing health risks in the extractives industry](#)

For more comprehensive information on dealing with each of the hazards, see our guidance [Work-related health](#)

The worker health PCP must also:

- provide for the development of strategies to deal with fatigue or consumption of drugs and alcohol (proportionate to the hazards present at the operation and to how a worker's behaviour may affect the worker's safety or the safety of others at the mining operation)
- set out a detailed process for obtaining urgent medical treatment for workers who suffer serious injury or illness at the mining operation, taking into account the nature of the terrain where the operation is located and the remoteness of the operation from the nearest hospital or other place where medical assistance may be provided.

The worker health PCP should be developed in the context of your health and safety management system, not separate to it. This will help identify gaps and overlaps when implementing control measures.

More information

WORKSAFE GUIDANCE

Managing health risks in the extractives industry [Managing health risks in the extractives industry](#)

MINEX HEALTH AND SAFETY IN NZ EXTRACTIVES

MinEx Guide to Worker Health in Extractives [Documents & guidelines](#)

5.0

Hazardous substances

IN THIS SECTION:

- 5.1 How hazardous substances are classified
- 5.2 Control measures for managing hazardous substances

Many chemicals and fuels used in extractives operations are hazardous and are controlled under the Health and Safety at Work (Hazardous Substances) Regulations 2017.

Hazardous substances used in the extractives industry include:

- explosives and detonators
- compressed gases
- petrol, diesel and liquefied petroleum gas (LPG).

You must manage risks to health and safety associated with using, handling, manufacturing or storing a hazardous substance or group of substances with the same hazardous properties at your workplace. You must eliminate risks to health and safety so far as is reasonably practicable. If you cannot eliminate a risk, you must minimise it so far as is reasonably practicable.

5.1 How hazardous substances are classified

Hazardous substances are classified based on the hazards they pose to people and the environment due to their hazardous properties. This helps determine how to manage the risks they cause. Each new hazardous substance imported into New Zealand or manufactured in New Zealand must be approved by the Environmental Protection Authority (EPA) and classified.

Hazardous substances may have one or more the following properties:

- explosive - hazard class 1
- flammable - hazard classes 2, 3 and 4
- oxidising - hazard class 5
- toxic - hazard class 6
- corrosive - hazard class 8
- toxic to the environment (ecotoxic) - hazard class 9.

5.2 Control measures for managing hazardous substances

Follow the control measures that apply for a substance's classification or classifications to manage the risks it poses.

The control measures vary depending on the risk of the hazardous substance, its hazardous properties, how much of it there is and how it is used.

The best way to know which control measures you have to follow is by creating an inventory listing what hazardous substances you have and in what quantities. Enter these details into the Hazardous Substances Calculator which will list the key control measures that apply to your substances. You can find the calculator here [Hazardous Substances](#)

More information

For more information on managing hazardous substances see [Your practical guide](#)

PART C

Planning and design

IN THIS PART

This part of the guide provides guidance for designing safety into extractives operations. It describes in detail how to plan excavations, tips, ponds, dams, roads and vehicle operating areas.

6.0

Planning safe excavations

IN THIS SECTION:

- 6.1 Introduction to planning safe excavations
- 6.2 Terminology
- 6.3 Identifying whether ground or strata instability is a principal hazard
- 6.4 Geotechnical assessments for mining operations, A-grade quarrying operations and A-grade alluvial mining operations
- 6.5 Geotechnical advice for B-grade operations
- 6.6 PHMP for ground or strata instability
- 6.7 Slope design
- 6.8 Ground support and reinforcement systems

Planning for safe excavations requires a good understanding of ground conditions and determining the ways in which potential ground failure could be avoided.

6.1 Introduction to planning safe excavations

A systematic approach to managing ground instability is very important.

When planning safe excavations, consider the unique characteristics of your site, the excavation method, and whether a geotechnical assessment should be done.

Planning also requires identifying hazards at your site, assessing risks and deciding suitable control measures often in consultation with workers and other PCBUs.

Ground conditions will significantly impact the excavation method you use and the control measures you put in place. The potential harm caused by unplanned and uncontrolled ground movements includes, but is not limited to:

- loss of life to workers or other people
- injuries to workers or other people
- collapse of, or damage to, nearby infrastructure
- interference with natural drainage and damage to surrounding land, natural habitats, wildlife or conservation initiatives and programmes
- unplanned failure of a slope occurring within proximity of a terminal boundary, encroaching on areas outside the approved area and breaching approval conditions
- loss of income, damaged business reputation, increased risk of prosecution
- disrupted operations, equipment losses, increased stripping and clean-up costs, lost customers, reduced business for your operation.

A geotechnical assessment can identify the type of ground conditions that exist at your site and tell you how these will most likely affect the ground stability of your operation.

In the planning phase, a competent person may be required to carry out a geotechnical assessment or provide geotechnical advice on ground conditions at your site. Information from the geotechnical assessment or advice will help you do an informed risk assessment and select appropriate control measures for your site. For more information on geotechnical assessments, see Sections 6.4 and 6.5.

6.2 Terminology

Slopes are generally designed as a series of **batters** separated by **benches** at predefined vertical height intervals (see Figure 4).

To keep a slope stable, make sure batter heights, bench widths, batter angles, inter-ramp slope height and slope angles are carefully designed.

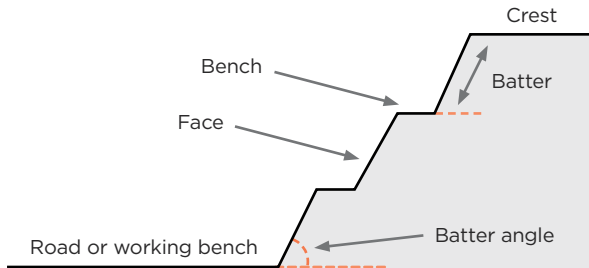

FIGURE 4:
Slope design terminology

Access to an excavation can be by a road or ramp, which may spiral around or be located on one side of the excavation with switchbacks at each end.

An **inter-ramp slope** is a series of batters between two access ramp sections or between a ramp section and the floor or crest.

The inter-ramp slope angle is always flatter than the **batter angle** in that slope.

The **overall slope** is the full height of a slope, from the toe to the crest, including several batters separated by benches (and access road sections if the road is on that slope). See Figure 5.

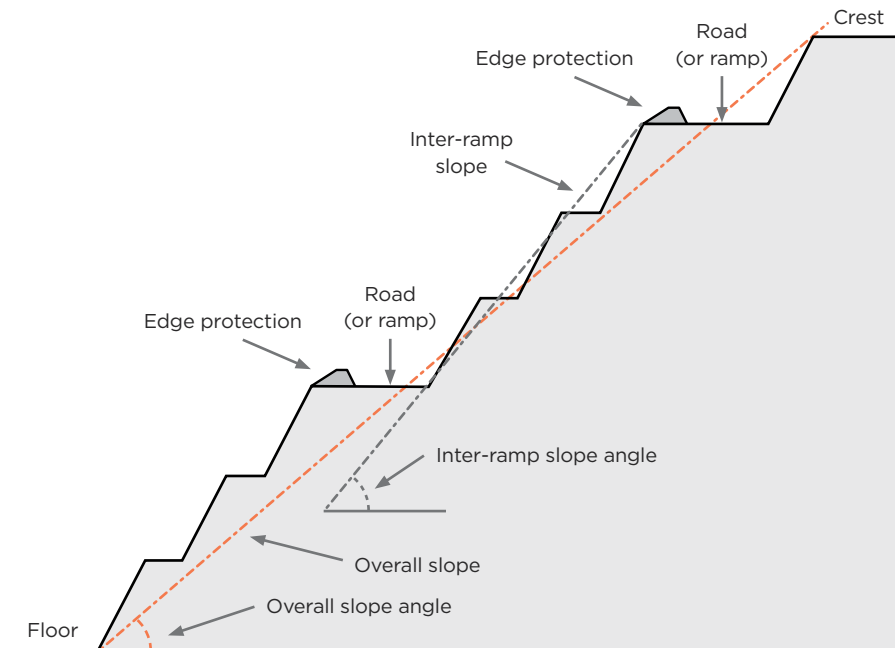

FIGURE 5:
Slope design
- inter-ramp and overall slope details

6.3 Identifying whether ground or strata instability is a principal hazard

The responsible person (SSE, alluvial mine operator or quarry operator) must carry out an appraisal of the operation to identify whether ground or strata instability is a principal hazard at mining operations and A-grade operations. Complete the appraisal with a cross-section of the workforce, and any other skilled and experienced people who can provide input about the hazard, as required.

During the appraisal, consider how an excavation might possibly fail and the likely consequences of such a failure. The consequences will depend on the scale of the failure (the size of the failure and the area it affects) and whether people could be killed or injured.

If ground or strata instability is identified as a principal hazard at your operation, the responsible person must make sure a competent person completes a geotechnical assessment. For more information on geotechnical assessments for A-grade operations, see Section 6.4.

For B-grade operations, geotechnical advice must be obtained if there are high-risk working faces present at the operation. For more information on geotechnical advice for B-grade operations, see Section 6.5.

For mining operations and A-grade operations, a principal hazard is more likely to be present where:

- the height of any individual face is more than 15m
 - there are soils and very weak rock where the height of any part of an excavation is more than 3.5m, and the overall slope angle is steeper than two horizontal to one vertical (27° to the horizontal) (see Figure 6)
 - the bottom of the excavation is more than 30m below the surrounding ground level (see Figure 7)
 - regardless of the excavation face height, depth or angle, other factors could create a principal hazard. For example, fractured rock mass or geological discontinuities (such as poor rock mass quality) or the location or proximity of a tip
 - there is unweathered, high-strength rock and well-cemented gravels.
- A geotechnical assessment should be carried out where the overall:
- height of any adequately benched slope, from toe to crest, is between 15m and 30m
 - slope angle is steeper than one horizontal to one vertical (1v:2h = 45° to the horizontal) (see Figure 7).

For more information on slope design, see Section 6.7.

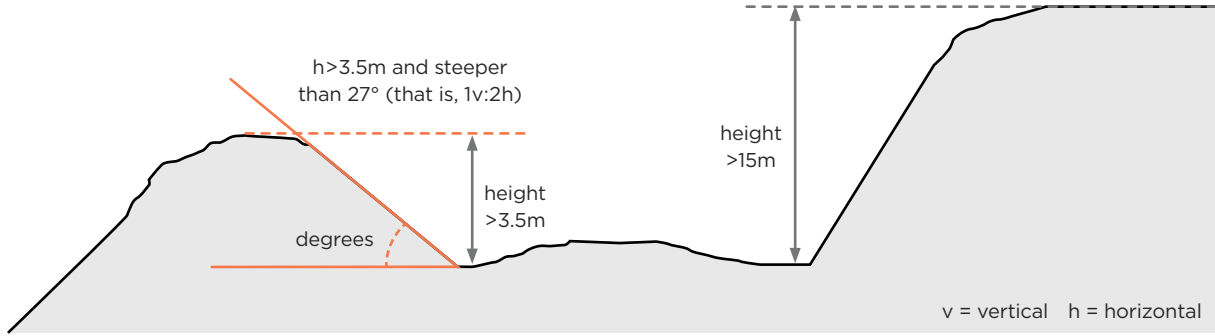

FIGURE 6: 'Soils and very weak rock' guidance

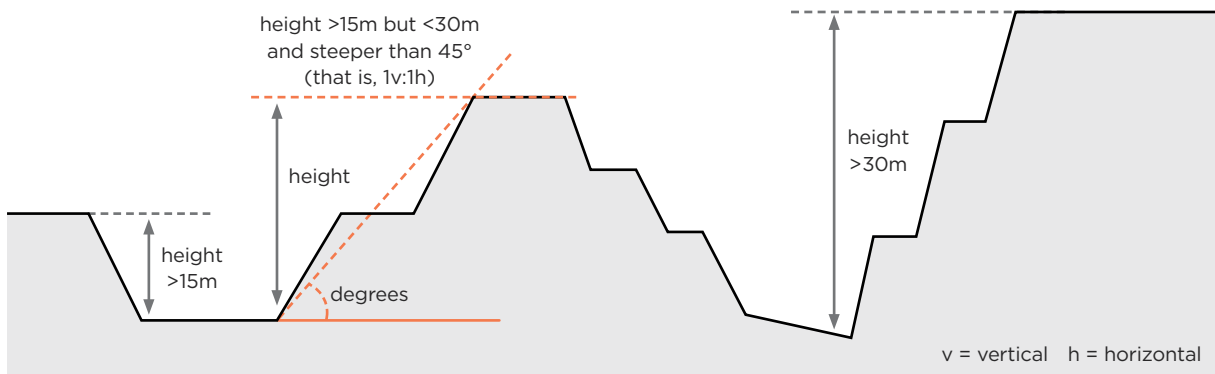

FIGURE 7: 'Stronger rock' guidance

Soils and very weak rock definition

The definitions of very weak and extremely weak rock are shown in Table 1.

TERM	FIELD IDENTIFICATION OF SPECIMEN	UNCONFINED UNIAXIAL COMPRESSIVE STRENGTH q_u (MPa)	POINT LOAD STRENGTH $I_{s(50)}$ (MPa)
Very weak	Crumbles under firm blows with point of geological hammer	1-5	<1
Extremely weak (also needs additional description in soil terminology)	Indented by thumbnail or other lesser strength terms used for soils	<1	

Note: No correlation is implied between q_u and $I_{s(50)}$

TABLE 1: Definition of soils and very weak rock as defined by the *New Zealand Geotechnical Society Incorporated Field Description of Soil Analysis Guideline (Dec 2005), Table 3.5 Rock Strength Terms*

Stronger rock definition

The definitions of stronger rock is shown in Table 2.

TERM	FIELD IDENTIFICATION OF SPECIMEN	UNCONFINED UNIAXIAL COMPRESSIVE STRENGTH q_u (MPa)	POINT LOAD STRENGTH $I_{s(50)}$ (MPa)
Extremely strong	Can only be chipped with geological hammer	>250	>10
Very strong	Requires many blows of geological hammer to break it	100–250	5–10
Strong	Requires more than one blow of geological hammer to break it	50–100	2–5
Moderately strong	Cannot be scraped or peeled with a pocketknife Can be broken with single firm blow of geological hammer	20–50	1–2
Weak	Can be peeled by a pocketknife with difficulty Shallow indentations made by firm blow with point of geological hammer	5–20	<1

Note: No correlation is implied between q_u and $I_{s(50)}$

TABLE 2: Definition of stronger rock as defined by the *New Zealand Geotechnical Society Incorporated Field Description of Soil Analysis Guideline (Dec 2005) Table 3.5 Rock Strength Terms*

6.4 Geotechnical assessments for mining operations, A-grade quarrying operations and A-grade alluvial mining operations

If ground or strata instability is identified as a principal hazard at a mining operation, A-grade quarrying operation or A-grade alluvial mining operation, the responsible person must make sure a competent person completes a geotechnical assessment to determine the level of ground or strata support needed to safely conduct the operation.

A geotechnical assessment of ground conditions is critical to developing a comprehensive PHMP.

The data collected during the assessment will be the foundation for:

- slope design and stability
- a suitable ground support system (where required)
- ongoing monitoring requirements suitable to the size and scale of slope design.

The geotechnical assessment should provide an indication of the risks and consequences of failure of your site. This may involve applying a factor of safety (FOS) calculation but could include more extensive probability analysis.

The geotechnical assessment should include information about:

- field data collection
- the geological features of the deposit, including:
 - the strength of the rock mass
 - hydrogeology
 - the orientation of geological structures
- formulation of a geotechnical model
- slope design, including the design of bench heights and bench widths, taking into account the excavation method and equipment
- the probability of failure or the factor of safety (FOS) of the overall excavation
- how to position the quarry faces for stability during blasting and excavation, including consideration of failure modes and how they will be managed
- the suitability of the design for short and long-term stability, and for maintenance of the faces
- the design of adequate space for haul roads, with provision for safety features as necessary, for example:
 - suitable road widths
 - inner rock trap and berms
 - outer edge protection (windrow)
 - face edge stand-off
- design, control and monitoring of blasting
- design, installation and quality control of rock support
- design of suitable monitoring systems
- inspection and monitoring requirements.

The geotechnical assessment may also include information about:

- possible seismic (natural or induced) or geothermal activity
- previously excavated or abandoned workings
- subsidence or settlement
- equipment and procedures used for scaling (cleaning)
- the effects of time and oxidation on ground support and stability
- geotechnical design life requirements during and after extraction.

Field data collection

Field data includes all the information which might affect the design, construction and performance of excavations such as:

- site history
- topography and geomorphology
- local climate
- hydrogeology and drainage
- physical geology and geologic structure
- lithology and rock mass properties.

Field data should be collected by a competent person, or a trained geotechnician who is supervised by an engineering geologist or geotechnical engineer.

There are several tools and techniques available for field data collection. These include:

- **surface geophysical** data collection methods which provide initial identification of major lithological units and structural features, such as fracture zones
- **downhole geophysics or logging** that provide data to determine lithological boundaries, structures and the in-situ mechanical, physical and chemical properties of the rock mass
- **core drilling** which enables an adequate understanding of the subsurface conditions for input to geotechnical design. The number of boreholes required depends on:
 - the level and reliability of already available geological and geotechnical information
 - the complexity of site geology
 - the size and operating life of the quarry or mine.
- **core samples** retrieved from boreholes which can be logged using direct observation, or with downhole cameras and digital photography
- **field testing**: geotechnical data collection from exposed rock can be carried out using 3D digital photogrammetric techniques
- **laboratory testing**: rock samples can be tested in a laboratory to determine intact rock properties.

6.5 Geotechnical advice for B-grade operations

A B-grade quarry operator or a B-Grade alluvial mine operator must obtain geotechnical advice from a competent person about any high-risk working face at the operation. A high-risk working face is one that:

- is at least 15m high, or
- poses a significant risk to workers as a result of one or more of the following factors:
 - the height of the working face
 - the ground type at the base of the working face
 - the angle of the working face's slope
 - the strength of the rock on the working face
 - the composition of the rock on the working face
 - the geological structure of the working face
 - the bedding surfaces of the working face
 - the presence of water (for example groundwater or surface ponding) on or around the working face, or
- is part of an excavation that, at its deepest, is more than 30m below the surrounding ground level.

B-grade operators should take geotechnical advice into account when developing, documenting, implementing, and maintaining the operation's health and safety management system (HSMS). After receiving geotechnical advice, a more detailed geotechnical assessment may be needed.

6.6 PHMP for ground or strata instability

At a mining operation, A-grade quarrying operation or A-grade alluvial mining operation, if ground or strata instability is identified as a principal hazard, the responsible person must develop a principal hazard management plan (PHMP). For general information about PHMPs, see Section 2.6.

Developing a PHMP

A PHMP should be developed in the context of your site's HSMS, not separate to it. This will help to identify gaps and overlaps when implementing control measures at your site.

For a full list of requirements for a PHMP, see Regulation 68 of the MOQO Regulations.

For PHMPs specifically for ground or strata instability, see Regulations 71, 117, 118 and 131 of the MOQO Regulations for the requirements.

Assessing the risks

A PHMP must include details of the risk assessment for the principal hazard – in this case, ground or strata instability. Workers should be involved in this process.

Table 3 shows some of the things to consider when carrying out a risk assessment for ground or strata instabilities.

VARIABLE	CONSIDERATIONS
Structure of the rock mass	Such as folding, faulting, strikes and dips
Rock strength	Such as 'very strong' or 'very weak' rock
Slope type	Active or inactive
Slope geometry	Overall slope height, slope angle, bench height, bench slope angle and bench width
Slope material characteristics (including alteration grade)	Rock or soil, structurally controlled, variable alteration or materials present, material or discontinuity shear strength parameters
Soil	Type, contaminated or non-contaminated
Proximity of existing structures	Property or services adjacent to both crest and toe of slope, both external and located on site
Proximity of workers at the site	Vulnerability, location relative to potential failure
Proximity of other people at the site	Proximity of public access, roads, footpaths and walkways
Failure mechanism	Rockfall, planar, wedge, toppling, rotational, flow and travel distance
Speed of failure	Rapid (flows, rockfall), slow (rotational), very slow (rotational)
Water (surface water and groundwater)	Visible signs of seepage or discharge, prevention of detrimental effects by effective surface water management
Past history of failure	History of instability (such as type, location), visible signs of active or previous failure (such as bulging slope surfaces)
Existing remedial measures	Bolting, regrading and pumping (dewatering)
Monitoring	Extensometers, piezometers, closure meters, Electronic Distance Measurement targets, radar
Seismic history	Frequency of earthquakes in the region, liquefaction and rockfalls
Operating variables	Exposure time of workers (duration of shift), excavation method, associated equipment (vehicle) exposure, effects of poor blasting

TABLE 3: Key considerations for risk assessments for ground or strata instabilities

Figure 8 shows what should be included when developing and maintaining a ground or strata instability PHMP. For more information on managing instability, see [Ground or strata instability in underground mines and tunnels](#)

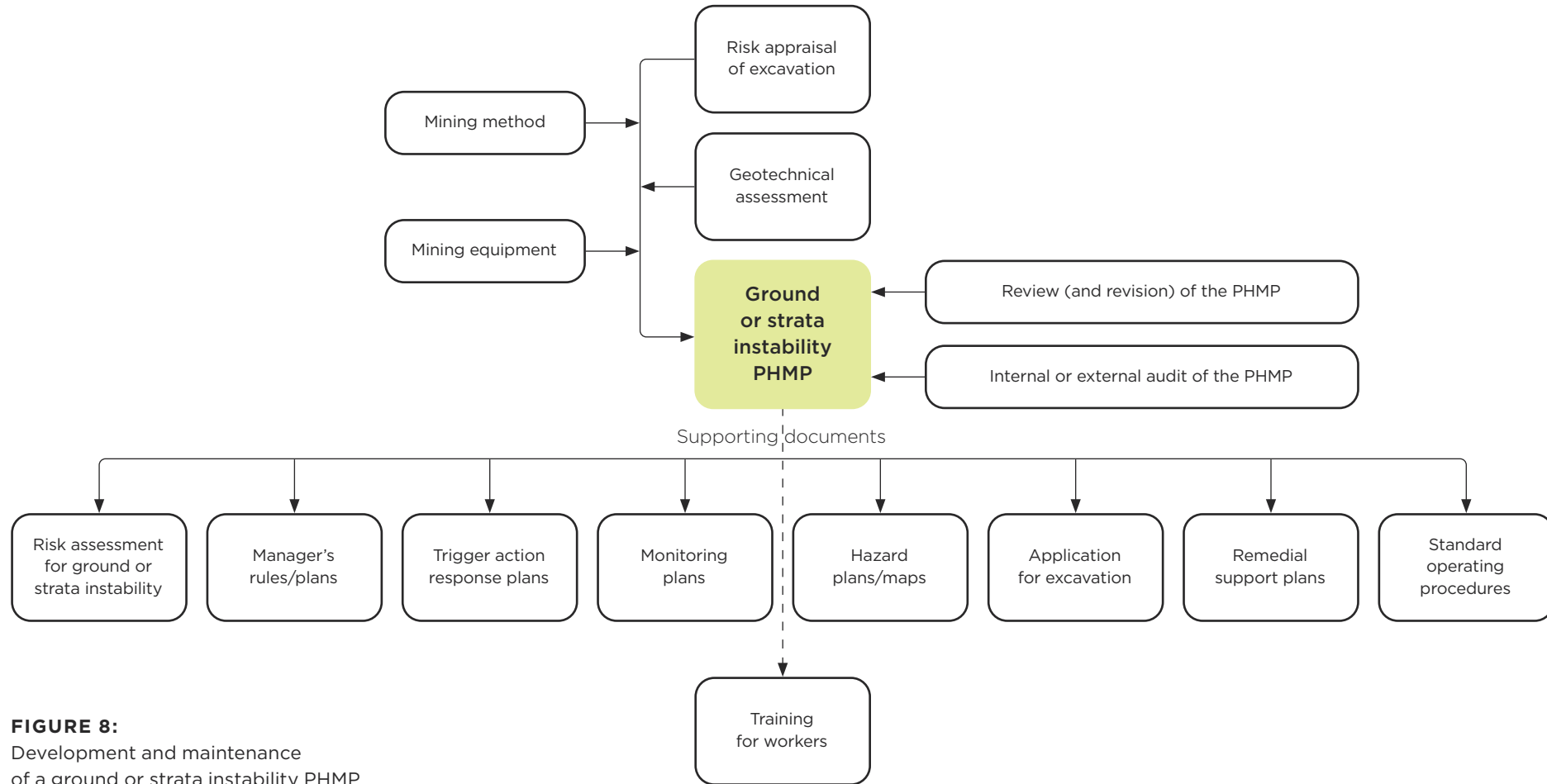

FIGURE 8: Development and maintenance of a ground or strata instability PHMP

6.7 Slope design

Slope designs should be suitable for the ground conditions of the site and, where necessary, include ground support or reinforcement.

There is a tendency to increase the slope angle to decrease waste rock stripping and try to generate a higher return on investment. But increasing the slope angle will weaken the stability of the slope potentially leading to slope failure.

By applying sound geotechnical engineering practices, safe slopes can be designed and maintained in almost any geological environment. An important consideration for designing slopes is the full life cycle of the slope including abandonment.

Varying parameters of bench height, bench width, batter face angle, and inter-ramp slope height and slope angle all contribute to improve overall slope stability. This section provides examples of these.

Slope stability analysis and factor of safety

Fundamental to slope stability analysis are the anticipated modes of failure, the scale of the slope, available data and the perceived risk relevant to the particular stage of the slope.

Whether a particular failure is 'acceptable' depends on its consequence and risk. If the failure of a particular slope has no bearing on its surroundings or safety and production, it is likely to be of minimal concern.

Slope design is governed by two factors: the consequence of failure and the degree of inherent uncertainty. It is good practice to apply a factor of safety (FOS) or probability of failure (POF) to the design. When the consequences of failure or the level of uncertainty are high, the design criteria should be altered accordingly (to a more conservative design). An example of the FOS and POF design criteria approach is shown in Table 4.

WALL CLASS	CONSEQUENCE OF FAILURE	DESIGN FOS	DESIGN POF	EXAMPLES
1	Moderately serious	1.2	10%	Highwalls not carrying major infrastructure
2	Serious	1.5	1%	Highwalls carrying major infrastructure (for example, treatment plant, run-of-mine (ROM) pad, tailings structures, crushing structures)
3	Serious (where a mutually acceptable agreement to allow excavation cannot be made between the quarry or mine owner and the 'owner' of the adjoining structure or plot of land)	2.0	0.3%	Permanent highwalls near public infrastructure and adjoining leases

TABLE 4: Example of FOS and POF design criteria approach

TYPES OF ANALYSIS

When developing stability analysis criteria, it is critical to understand the origins and limitations of the various geotechnical engineering design procedures.

You should also acknowledge that there are risks that can be created by unexpected conditions.

Examples of analysis methods include:

- rock mass rating (RMR) and mining rock mass rating (MRMR) classification systems
- kinematic analysis of structurally controlled failures
- limit equilibrium analysis
- numerical analysis.

Modes of failure

Collecting and interpreting information about major structures and other geological features is important in determining their potential for failure.

Steeper and higher slopes or batters will generate greater driving forces. This increases the potential for rock mass failure and presents a higher risk. Slopes or batters excavated within rock masses that contain persistent geological structures have greater potential to develop large-scale wall failures.

It is more important (and usually more difficult) to control large slope failures than small slope failures. Control measures for a large slope failure include:

- excavating slopes or batters to a shallower angle
- depressurisation of groundwater in the rock mass
- installing ground support and reinforcement.

Basic modes of failures are listed here.

Planar failures occur when a geological discontinuity, such as a bedding plane, strikes parallel to the slope face and dips into the excavation at an angle steeper than the angle of friction.

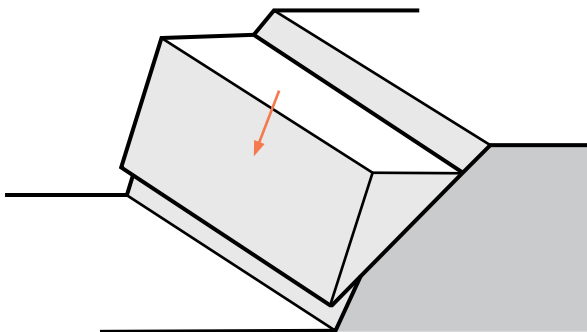

FIGURE 9:
Planar failure

Wedge failures occur when two discontinuities intersect and their line of intersection daylights in the face.

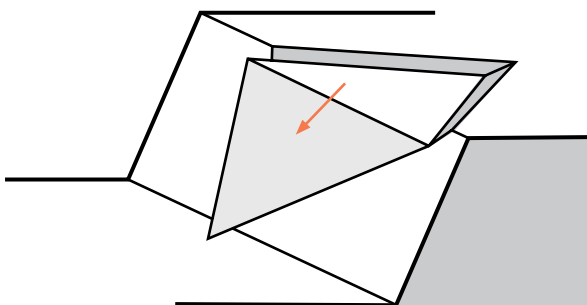

FIGURE 10:
Wedge failure

Step-path failure is similar to planar failure, but the sliding is due to the combined mechanisms of multiple discontinuities or the tensile failure of the intact rock connecting members of the master joint set.

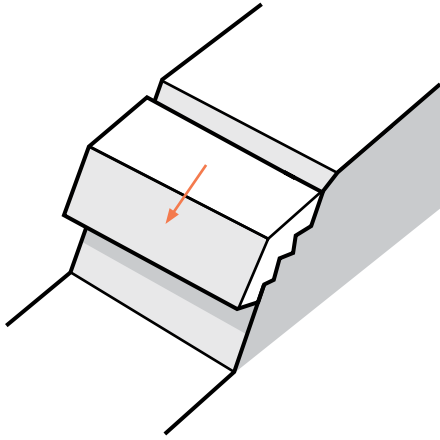

FIGURE 11:
Step-path failure

Ravelling is the weathering of material and the expansion and contraction associated with freeze-thaw cycles are the main causes of ravelling. This type of failure generally produces small rockfalls, not large failures.

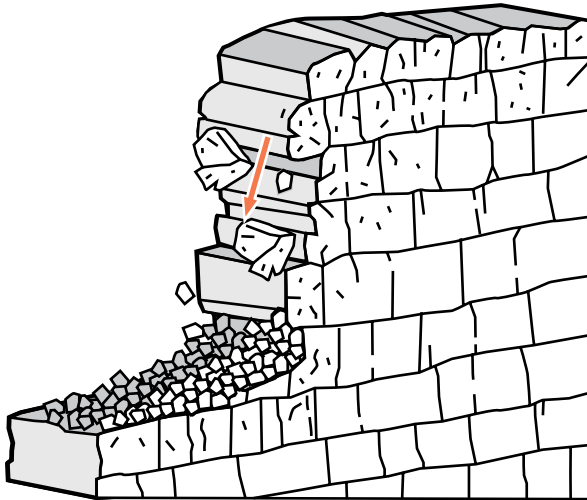

FIGURE 12:
Ravelling failure

Toppling can occur when vertical or near-vertical structures dip toward the pit. In this case, the bench face height should be limited to a distance roughly equal to the bench width. This will help catch any toppling material and reduce the chances of it hitting workers on the pit floor.

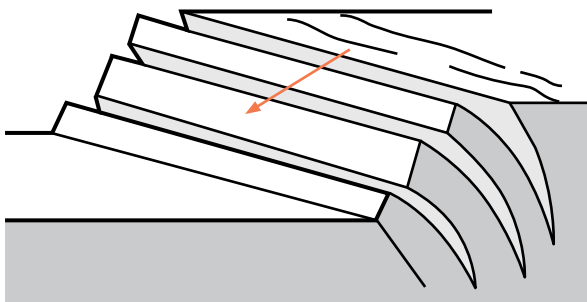

FIGURE 13:
Toppling failure

Circular failures (or slumps) occur in weak rock or soil slopes. They do not necessarily occur along a purely circular arc, but some form of curved failure surface is usual. Failures can occur at the surface (slope failure), at the toe (toe failure), or at depth in a weak zone.

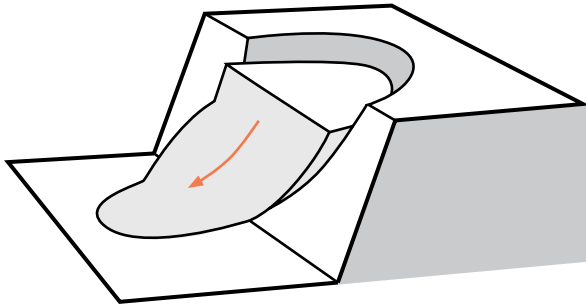

FIGURE 14:
Circular failure

Batter and final bench design

BATTER HEIGHT AND REACH

The height of batters should be determined on an individual basis, based on past extraction conditions of the seam or area, and sound engineering practices.

Maximum batter height should be based on:

- the recommendations of a competent person
- reliability of the batter design (that is, stability under potential failure modes)
- availability of equipment for adequate scaling to remove loose piece of rock.

Batter height should not exceed the safe reach of the equipment available to clean (scale) the face, unless control measures are in place. These control measures could include:

- blasting practices that shoot the face clean
- using mobile plant or equipment capable of working a safe distance from the toe while removing material to the toe
- using mobile plant or equipment to clean the face from the top edge.

BENCH SPACING

Where a slope contains many discontinuities (such as joint sets or bedding planes), having benches at select spacings can increase the stability of the slope.

Benches should be wide enough to stop potentially hazardous rock falls and contain any spills from the batters above from falling into the excavation and harming workers.

Where there is minimum space between benches and small-size rill material is still not contained, review your control measures. Be prepared to revise them to stop material falling into the excavation and workers being exposed to harm.

Control measures to consider:

- providing a bench or additional benches in the slope
- widening bench widths
- modifying blasting techniques
- changing the orientation of mining or extraction
- more effective cleaning methods.

BENCH WIDTHS

The width of benches is determined by several factors.

- If no other control measures are in place (such as rock fences), the bench should be wide enough to stop rockfalls and contain any material that falls from the wall above the bench.
- Extended exposure of the wall can cause rilling material to accumulate on the bench. Cleaning may be needed to maintain the bench's effectiveness. When cleaning benches, the bench width should accommodate any equipment used on it. Safe access to the bench must be provided.
- Bench widths should allow for adequate drainage.

When designing bench widths, consider the likelihood of achieving the design width. Even with good blasting and excavation control, the design may not be achieved.

The width that can practically be achieved depends on the amount of back-break along the crest during excavation. Back-break from blasting can extend into the bench as much as three meters. Presplitting can reduce back-break if the holes are spaced close enough and plugged as near to the top of the hole as possible. This reduces the amount of stemming.

Consult an explosives contractor or supplier about other techniques that can be used to safely manage back-break.

The design of bench widths must also allow adequate space for haul roads with inner rock trap and berm, windrows, and face edge stand-off.

Working bench widths

To determine working bench widths, consider the type of equipment and the method of extraction. Make sure there is enough room to allow:

- exclusion zones to be set up where there are unsafe ground conditions
- bench access to be a suitable distance from the batter face
- excavating mobile plant to work
- trucks to queue safely while waiting to be loaded
- trucks being positioned correctly and safely during loading.

Do not allow workers or other people near hazardous batters or benches. Unsafe ground conditions should be dealt with immediately and corrected or treated as an exclusion zone.

Overall slopes

The methods of analysis for the design of overall slopes are the same as those for batter design, except the scale is different.

In stronger rocks, overall slopes may fail by planar and wedge sliding. In soils and weak rocks, they may fail by toppling and rotational shearing.

More complex collapses involving failure through the rock mass will require analysis by numerical methods.

Batter stability immediately below and above the access ramp should also be considered when designing inter-ramp slopes.

Batter instability immediately below could undermine the ramp and instability immediately above could spill onto the ramp.

Groundwater and surface water control

Mines or quarries excavated below the groundwater table may need dewatering and depressurisation. The most significant problem is the effect water pressure has on slope stability. Water pressure in structural defects in the rock mass and pore spaces in rock material reduces effective stress and, consequently, shear strength.

At some sites with minor groundwater inflow from slopes or floor, dewatering may occur simply through evaporation. At other sites, major pumping operations may be necessary. Groundwater can also be controlled with methods such as:

- production bores (used before and during extraction)
- sumps or trenches
- sub-horizontal drainage holes drilled into the slopes.

Each method can be used individually or in combination. The most appropriate method for your site will depend on:

- local and regional hydrogeological conditions
- the relative importance of depressurisation to the specified design, and
- the required rate of production.

At large sites, all three methods may be needed to control groundwater.

Where complex groundwater issues could have a direct impact on ground stability, this may require input from an engineer specialising in geohydrology.

Control of surface water drainage is also an important aspect of slope design.

Surface water drainage paths through and around the site should be designed, constructed and maintained so water does not pond at the crest or toe of critical slopes.

To stop scouring on a face, do not discharge water over a face except in a single controlled point. If possible, the water should be directed along the bench to the roadway and along an open drain to a collection point, sump or settling pond.

6.8 Ground support and reinforcement systems

Ground support generally includes rock or cable bolts installed in the ground. Reinforcement systems (artificial support) can include retaining walls, drilled or cast in-place piles, earth and rock anchors, or reinforced earth.

Responsibilities for ground or strata support

The manager of the operation must make sure that:

- suitable ground or strata support or stabilisation systems are designed and used in all working areas, as required by Regulation 117 of the MOGO Regulations
- plans showing the ground or strata support or slope stabilisation arrangements are displayed where workers can easily access them.

Installing ground or strata support

A relevant operator must make sure that:

- no person enters areas with unsupported or unstable ground unless they are:
 - installing or supervising ground or strata support
 - carrying out or supervising slope stabilisation work
- temporary support is provided to keep workers safe when:
 - installing or supervising the installation of ground or strata support
 - carrying out or supervising slope stabilisation work.

Design considerations

When designing a ground support and reinforcement system, it should match the ground conditions of your site. Also consider:

- the function of the support (such as to prevent rock fall, slope failure or rockslides)
- the geological structure in and around the slope
- in-situ rock mass strength and behaviour of the rock support or reinforcement system under load
- groundwater regime and chemistry, rock stress levels and the changes in rock stress during the life of the excavation
- the potential for seismic events such as earthquakes or blasting
- retaining the overall factor of safety.

TIMING OF INSTALLATION

Generally, the earlier ground support is installed, the more effective it is.

Install the system as soon as practicable to limit potential loosening and unravelling of the rock mass. Long delays in installation may weaken the system's effectiveness.

Ideally, potentially unstable wedges or blocks should be secured as excavation continues, with ground support being progressively installed.

CORROSION

Due to corrosion, no ground support system will last indefinitely. Using galvanised components may prolong its usefulness.

QUALITY CONTROL

Each element or layer of artificial support should be combined so that the overall system is well matched to the ground conditions for the design life of the excavation.

Develop a quality control procedure to make sure the standard of installation of artificial support meets the design expectations for all ground conditions at the site.

Artificial support measures

Artificial support can be categorised into four main groups:

- rock bolting systems
- retaining type structures
- surface treatments
- buttressing.

Table 5 details these four categories of artificial support measures.

TYPE OF SUPPORT	DESCRIPTION
ROCK BOLTING SYSTEMS	
Rock bolting systems typically fall into three categories: rock bolts, dowels (shear pins) and cable bolts. These systems can be improved by connecting individual components by welded mesh or strapping.	
Rock bolts	Tensioned once anchorage is achieved, to actively set up a compressive force into the surrounding rock. This axial force increases the shear capacity and is generated by pre-tensioning of the bolt. In essence, rock bolts start to support the rock as soon as they are tensioned. Commercially available rock bolts include cone and shell, grouted and chemically (resin) anchored rebar.
Rock dowels	Can be used instead of rock bolts, when installation of support can be carried out very close to the excavated face or in anticipation of stress changes that will occur at a later excavation stage. Rock dowels are passive reinforcements that need some ground displacement for activation.
Cable bolting	An established technique used extensively for reinforcement of the rock mass adjacent to surface excavations. They can be tensioned or un-tensioned and may be fully or partially grouted. Thread-bar rock anchors or multi-strand tendon cable anchors can be used where higher loads are required.
Shear pins	Reinforcement bars or larger steel, concrete or post sections that may be grouted in situ. They are designed to be placed perpendicular to a particular discontinuity and to act mainly in shear. The support provided by the shear pin is equal to the shear strength of the steel bar and possibly the cohesion of the rock/concrete surface. Although shear pins are mainly installed perpendicular to the potential slide plane, there are some other applications. These can involve horizontal installations to provide shear support to blocks defined by flat-lying underground workings intersecting the pit wall, or unstable clay seams within an eroded rock wall.
Mesh	Where bolting alone is insufficient and support is required for small, fractured material, welded or arc mesh secured to the rock bolts, dowels or cable bolts is a suitable form of support. Usually, a 100mm x 100mm mesh is used, but the size is determined by the desired bag strength. The use of mesh in very blocky ground reduces the potential for unravelling and can be a very useful ground support method.
W strapping	Used to connect the collars of rock bolts. They are nominally 2-3mm thick and 200-300mm wide and can be bolted to follow the contours of the rock face. Support tension can be exerted between bolt sets through the strap.
RETAINING TYPE STRUCTURES	
Retaining walls are typically formed from precast concrete or in situ poured concrete, steel sheet piling or bored piles. Walls can be reinforced or un-reinforced and can be tied back with tendons into the rock. Proper drainage behind the wall is critical to their performance. Drainage material will reduce or eliminate the hydraulic pressure and increase the stability of the fill material behind the wall.	
Gabion walls	A traditional, effective and practical means of stabilising cuts and slopes. As they apply a surcharge load to the underlying pit wall, they must be installed upwards from a location where there is strong enough rock for a suitable foundation.
Stacked tyres	An alternative to gabions and may be simpler and cheaper to install. Each stack of tyres should be filled and secured.
Reinforced earth	Retaining walls are gravity structures consisting of alternating layers of granular backfill and reinforcing strips with a modular precast concrete facing. Because of their high load-carrying capacity, reinforced earth is ideal for very high or heavy-loaded retaining walls.
Tied-back walls	These generally comprise a concrete wall, often reinforced with mesh or reinforcement bars tied back into the rock wall using cable bolts, or rock bolts in smaller structures. These walls are particularly suited to mining applications where they can be constructed progressively as the benches are mined, using cable bolting meshing and a shotcrete application.
Steel sheet piling	Often used in soft soils and tight spaces. They are made of steel, vinyl, fibreglass or plastic sheet piles driven into the ground and can require a tie-back anchor 'dead man' tied by a cable or a rod. For more detailed information on shoring methods, see our guidance Excavation safety

TYPE OF SUPPORT	DESCRIPTION
SURFACE TREATMENTS	
Shotcrete lining	Provides ground support and can lock key blocks into place. It also protects the rock against erosion by water and weathering. To protect water-sensitive ground, the shotcrete should be continuous, crack-free and reinforced with a wire mesh or fibres.
Fibrecrete (steel fibre reinforced shotcrete)	Where steel fibres are incorporated in the shotcrete to improve its crack resistance, ductility, energy absorption and impact resistance characteristics. Properly designed, fibrecrete can reduce or eliminate cracking, a common problem in plain shotcrete.
Slope erosion protective measures	These are about protecting slopes that are highly susceptible to erosion from rain and wind. A rock or cobble cover of 300mm thickness is usually sufficient to protect against wind and rain. Alternatively, grasses can be used.
Rock netting	Linked steel wire and rings connected into sheets. Draped over a face, they limit rock movement and the energy in any movement. Useful in poor ground where fretting needs to be controlled.
Hydro-seeding	A popular method of quickly establishing grasses on steep batters.
BUTTRESSING	
Buttressing is a simple method of increasing slope stability to increase the weight of material at the toe, creating a counterforce that resists failure. A berm or buttress of earth or rock fall can simply be dumped onto the toe of the slope.	
Broken rock or riprap	Preferred to overburden because it has a greater frictional resistance to shear and is free draining, reducing problems with plugging groundwater flow.
Shear trenches or shear keys	Provide increased shearing resistance to failure and also serve as a subsurface drain. A shear trench is frequently a good supplement to flattened slopes and berms. Shear trenches should extend the full length of the slope.

TABLE 5: Artificial ground support measures

7.0

Planning for tips, ponds, voids and dams

IN THIS SECTION:

- 7.1 Identifying tips, ponds, voids and dams as principal hazards
- 7.2 PHMP for tips, ponds or voids
- 7.3 Planning and design criteria for tips
- 7.4 Planning and design criteria for ponds or dams
- 7.5 Construction of a tip or pond
- 7.6 Rehabilitation of tips

A well-designed and constructed tip, pond or dam will have the lowest long-term operational risk, such as structural failure.

7.1 Identifying tips, ponds, voids and dams as principal hazards

At a mining operation, an A-grade quarrying and alluvial mining operation, the responsible person for the operation must carry out an appraisal of the operation to identify principal hazards. The responsible person should seek technical advice from a competent person, as required.

To determine whether tips, ponds, voids or dams are a principal hazard, the responsible person should consider how they might fail, and the likely consequences if they do.

The consequences will depend on:

- the size of the failure and the area affected
- whether people are likely to be killed.

Typically, a principal hazard exists where:

- the tip is, or will be, in a wholly or mainly solid state and not in solution or suspension (that is, not likely to flow if it is not contained), and:
 - the area of the tip exceeds 10,000m², or
 - the height of the tip exceeds 15m, or
 - the average gradient of the land covered by the tip exceeds 1 in 12 (see Figure 15)
- the tip or pond contains, or will contain, any liquid or material wholly or mainly in solution or suspension (that is, likely to flow if not contained), and:
 - the contents of the tip or pond is more than 4m above the level of any land which is within 50m of its perimeter, or
 - the contents of the pond exceeds 20,000m³ (see Figure 16)
- regardless of the size of the tip, pond or void, other factors (for example the geology, location of or proximity to an excavation) means there is a principal hazard
- vehicles operate near the edge of the tip, pond, void or dam.

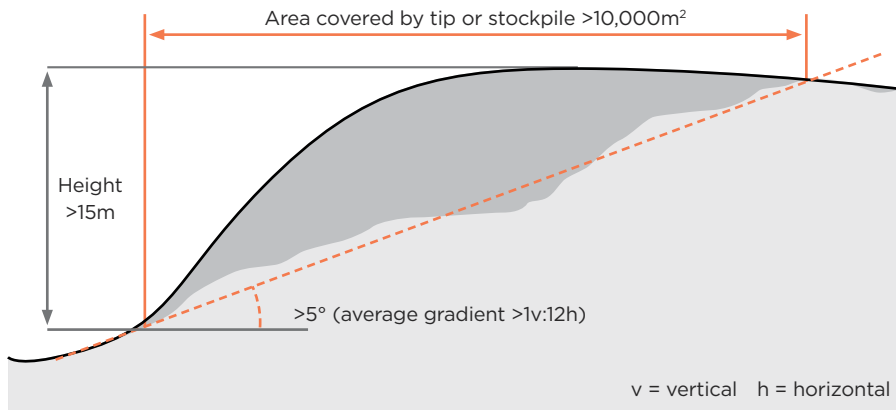

FIGURE 15:
How to determine if tips (solid) are a principal hazard

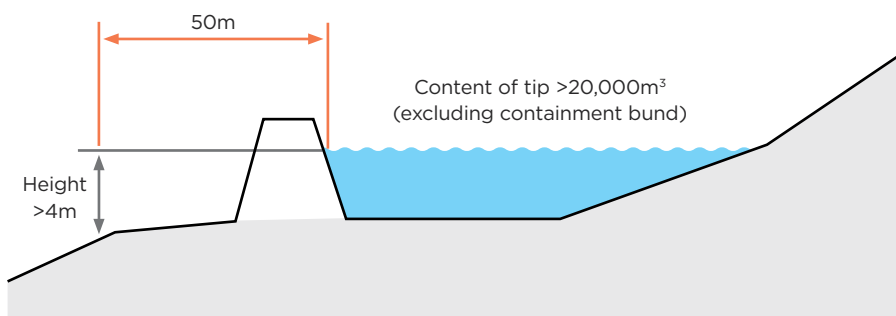

FIGURE 16:
How to determine if tips (liquid) and ponds are a principal hazard

7.2 PHMP for tips, ponds or voids

If the risk appraisal finds that tips, ponds or voids are a principal hazard at your site, the responsible person must ensure there is a PHMP. For general information about PHMPs, see Section 2.6.

A description of how the risk assessments will be conducted, as well as the results of the risk assessment, must be included in the tips, ponds and voids PHMP.

In addition, the responsible person must make sure a reassessment of the stability of the tip, pond or void is carried out by a competent person:

- at least once every two years after the date the PHMP is made
- when the construction of a tip, pond or void deviates from the geotechnical design
- if a new tip, pond or void is created.

WHEN THE RESPONSIBLE PERSON MUST PUT A PHMP IN PLACE

For mining operations, a PHMP must be in place, if a tip is or will be:

- located on a slope
- greater than 15m in height, and
- greater than 100,000m³ in volume.

WHAT THE RESPONSIBLE PERSON MUST INCLUDE IN THE PHMP

PHMPs for tips, ponds or voids must contain the general PHMP requirements listed in Section 2.6 of these guidelines and Regulation 68 of the MOQO Regulations.

It must also include:

- procedures and processes to ensure the safe design, construction and maintenance of tips, ponds or voids
- a geotechnical assessment
- road design and traffic movement
- tipping rules
- records of tipped material
- an inspection and monitoring regime.

For a full list of requirements for tips, ponds or voids PHMPs, see Regulation 81 of the MOQO Regulations.

Where the PHMP requires regular inspections, the PHMP must specify:

- the nature and interval of inspections
- the appointment of a competent person to supervise tipping operations, including a requirement that this person supervises every tip inspection.

Develop the PHMP in the context of your entire HSMS. This helps identify any gaps and overlaps when putting control measures in place for tips, ponds and voids.

Geotechnical assessment

If you identify a tip, pond or voids as a principal hazard at your site, you must arrange for a geotechnical assessment.

This assessment must be proportionate with the type and scale of tipping operations and consider the:

- underlying geotechnical structure at the tip site
- properties of the material being tipped
- creation of any ponds or voids.

The geotechnical assessment should tell you the type of foundation and surface treatment needed, which may include:

- removing unsuitable, weak material from the foundation
- benching of the foundation
- installing under-drains and final slope toe drains
- installing surface cut-off drains.

Data from the geotechnical assessment should be used to develop a geotechnical design that establishes an appropriate foundation for your site. The assessment should also recommend maximum lift heights, depths, volumes and maximum overall tip height.

Records to be kept

If you identify a tip, pond or void as a principal hazard at your operation, the PHMP must include record keeping of materials being tipped.

7.3 Planning and design criteria for tips

You should consider tipping and storage of waste material at your site. This should occur during the project's planning phase, not towards the end or after the site design is finalised.

When choosing control measures to manage risks at tips, consider:

- the geology of the area (particularly the foundation of the tip, foundation materials and tip materials)
- the quantity, type, and rehabilitation of overburden
- the type and size of mobile plant to be used
- access roads for vehicles and pedestrians
- preparation of the receiving area
- settling requirements, drainage and runoff controls
- stabilising methods, including inspections
- the risk of spontaneous combustion
- controlling public access
- any other hazards (for example, overhead power lines).

Tip sites should be able to safely receive waste material. This includes removing vegetation and topsoil, and keying into the substrata to ensure the stability of the material placed above.

Tree felling

Where tree felling is needed, only competent people with appropriate tree felling qualifications should undertake the work. WorkSafe must, so far as is reasonably practicable, be notified at least 24 hours before you intend to undertake tree-felling.

The following guidelines from Safetree may be useful [Safetree](#)

Subsoil drainage

Subsoil drainage should be considered to ensure there can be no liquefaction of the material placed there.

This can be as simple as placing large rocks to allow moisture to 'wick' through, or using drain coils and piping to capture and carry moisture through the waste material to a controlled discharge located below the tip.

Water diversion and drainage structures should be designed and implemented according to acceptable engineering standards and be functional for the life of the tip.

If tip rehabilitation is needed, it should be completed as soon as possible to prevent scouring and water damage through erosion.

Access roads

Access roads and other vehicle operation areas should be designed according to engineering standards. Criteria should include:

- road width
- road gradient
- edge protection
- signage
- speed limits

- lighting
- overhead hazards
- passing rules.

For more information on roads, see Section 8.

Adjacent stockpiles

Adjacent stockpiles can influence each other (for example, stability may be altered when they overlap). The adequacy of vehicle routes should also be considered when planning the position and size of stockpiles. In particular, the risk of collision can be minimised by making sure drivers have a clear field of view. For more information, see Section 14.10.

7.4 Planning and design criteria for ponds or dams

You must eliminate risks at your pond or tailings dam, so far as is reasonably practicable. If the risks cannot be eliminated, you must minimise them, so far as is reasonably practicable. This includes during operations, decommissioning and after the pond or dam has been abandoned. Some common hazards include:

- seepage
- dust generation
- exposure to chemicals or hazardous particulates
- erosion
- overtopping
- abrupt failure of a retaining structure
- impediment of surface water flows
- pollution.

When designing and selecting the site for a pond or dam, some things to consider include:

- hydrology (potential for flooding and catchment area characteristics)
- topography (influence of watershed, streams and creek systems)
- foundation material (water tightness, strength and liquefaction potential)
- foundation conditions (physical, geochemical and geotechnical properties)
- characteristics of construction (suitability, availability and proximity)
- characteristics of tailings material (physical, geochemical and geotechnical properties)
- climate (rainfall patterns, evaporation rates and prevailing winds)
- geology (faults, fractures, shear zones and areas of instability)
- hydrogeology (potential impact on ground water resources)
- seismicity
- minimum freeboard
- seepage control methods
- characteristics of embankment or other retaining structures (stability, erosion resistance, resistance to dynamic or static liquefaction and integrated waste landform)
- operating strategy
- access requirements
- characteristics and availability of cover and rehabilitation methods
- whether there are any populated areas downstream which may be adversely affected in the event of a failure.

Planning should ensure the pond disposal area is left in a condition where it will:

- maintain an acceptable level of risk control (for example, for dust control or access)
- remain structurally stable
- resist deterioration through erosion and decay
- prevent loss of containment.

7.5 Construction of a tip or pond

Develop and put in place a construction plan to make sure the tip or pond construction meets design specifications and tolerances. This should include quality assurance procedures.

The plan should also include systems of work and procedures to make sure the proposed construction can be carried out safely.

Use a competent person to ensure construction of tips or ponds meet design specifications and tolerances. They should document:

- the conditions encountered during construction (including field and laboratory testing), verified against the design assumptions
- corrective measures taken where conditions did not meet the original design or specifications
- all changes required that deviated from the original design
- the testing and measurement regime used to validate the design parameters
- survey data and drawings of the tip or pond construction.

The design should show the true locations of:

- borrow pits and embankments
- drains and seeping trenches
- topsoil stockpiles and capping material sources
- process water and return water ponds
- monitoring instrumentation
- decant towers
- buried pipework and cables.

The construction records and monitoring data form the basis for the design of subsequent stages. If construction is staged, prepare a separate construction report for each stage.

Your tip or pond may also be considered a dam under the Building Act 2004.

You can view the Building Act 2004 at legislation.govt.nz

For more detailed information on dam notifications, dam classification, dam safety assurance programmes or dam compliance certificates, see [Dam safety requirements](#)

Drainage of a tip

If sufficient water is present, either from heavy rainfall or other sources, some or all of a tip can become saturated. In this case the water in the saturated portion has a buoyant effect and reduces the strength of the material, making the tip more prone to sliding. Therefore, measures should be taken to make sure water drains away.

Water should never be allowed to accumulate against or on any part of the tip, unless it is specifically designed as a dam or pond. Seal off the surface of a tip, using mobile plant to compact the surface and minimise the water penetrating into the fill material.

If tips are constructed above an existing water course, the water course should be diverted or culverts of sufficient size provided to channel the water through the tip area.

The tip should have internal drainage to deal with expected rainfall. This is usually provided by under-tip drains or coarse, permeable layers positioned at appropriate levels. Internal drainage systems should be designed by a suitably competent engineer or hydrologist.

Drainage systems should be maintained.

Dam safety scheme

For storing water or another fluid under constant pressure you must comply with the requirements of a dam, as set out in the Building Act 2004.

Structures at extractives sites that may fit the definition of a dam include settling ponds, tailing dams and reservoirs.

7.6 Rehabilitation of tips

When the site is temporarily (suspended) or permanently closed (abandoned), it should be left in a safe condition.

Typically, rehabilitation is carried out progressively. This means parts of the site can be abandoned, while other parts are still operational. For example, rehabilitation of overburden tips that have reached capacity.

The objectives of abandonment of all or part of a site are:

- to make sure the public is safe by preventing inadvertent access to site infrastructure
- to provide for the stable, long-term storage of overburden and tailings
- to make sure the site is self-sustaining and prevent or minimise environmental impacts
- to rehabilitate disturbed areas for a land use (for example, returning disturbed areas to a natural state or other acceptable land use).

Rehabilitation should address water runoff, air quality, stability of material, erosion control, and treatment and containment of all possible hazardous substances.

Stability of material and control of water runoff are the most important factors as they will be the first indicators of any problems in the rehabilitated area. Stability should be monitored by a study of the toe area of any overburden tip. Make sure the toe area is well compacted and not bulging or moving out from its original placement. Another indicator of movement would be cracks appearing around the crest or top of the rehabilitated tip.

Rehabilitation tends to be a condition for all new resource consents and most current resource consents.

Rehabilitation should be considered and incorporated into all aspects of site planning, construction, and operation. This allows key aspects of the abandonment to be planned for throughout the site's life cycle. Plans should identify measures to be undertaken during the operations phase, aimed at progressive rehabilitation of disturbed or developed areas of the site.

Review and revise rehabilitation plans as necessary throughout the site's life cycle. The plans may become more detailed, incorporating more site-related activities and consideration of other site conditions.

8.0

Planning for roads and other vehicle operating areas

IN THIS SECTION:

- 8.1 Appraisal of roads and other vehicle operating areas
- 8.2 PHMP for roads and other vehicle operating areas
- 8.3 Design and layout of roads
- 8.4 Traffic management plan

Roads and other vehicle operating areas can create significant hazards at an extractives site.

A well-designed and maintained site will make workplace vehicle accidents less likely.

This section is useful for all extractives sites when designing roads and other vehicle operating areas.

For mining operations and A-grade quarrying and A-grade alluvial mining operations, this section will assist with the drafting of the principal hazard management plan (PHMP) for roads and other vehicle operating areas.

To determine what hazards may be present, consider what vehicle activities will take place on a road or other vehicle operating areas.

Hazards associated with roads and other vehicle operating areas include:

- vehicles rolling over or going over edges
- trays flipping over on articulated dump trucks
- ground failure onto or below vehicles
- collisions between vehicles and between vehicles and pedestrians
- uncontrolled movement of vehicles
- vehicles coming into contact with overhead power lines or other structures.

8.1 Appraisal of roads and other vehicle operating areas

For mining operations, A-grade quarries and A-grade alluvial mining operations, the responsible person must carry out an appraisal of the operation to identify principal hazards.

To determine if roads and other vehicle operating areas are a principal hazard, the responsible person should consider:

- how a road or other vehicle operating area could fail (for example, collapse or slips) and the likely consequences of a failure
- the type of vehicles using the road or other vehicle operating areas
- the activities that take place and the consequence of any interactions between vehicles and pedestrians, structures or other vehicles, for example:
 - vehicles carrying passengers
 - light and heavy vehicle interactions
 - travelling under overhead power lines
 - loading over a cab where a driver may be present

- how a vehicle may lose control and the likely consequences (for example, driver falling asleep, mechanical failure or tip over)
- the hazards on the road or other vehicle operating area (for example, sharp corners, steep gradients or large drop-offs)
- any other hazard involving vehicles.

The responsible person should consult a competent person for technical input and advice as required when considering whether a principal hazard exists.

A risk assessment must be completed for the roads and other vehicle operating areas principal hazard. A description of how you will conduct the risk assessment, as well as the results of any risk assessments completed, must be included in the roads and other vehicle operating areas PHMP.

8.2 PHMP for roads and other vehicle operating areas

Where an appraisal has identified a principal hazard, the responsible person must make sure there is a PHMP.

What the responsible person must include in the PHMP

The PHMP must contain the general PHMP requirements listed in Section 2.6 of these guidelines and Regulation 68 of the MOQO Regulations. Before drafting the PHMP, the responsible person must take into account:

- the characteristics of the vehicles and other mobile plant to be used
- the conditions of the road or other vehicle operating areas at the operation (including time of day, visibility, temperature and the effects of the weather).

For a full list of requirements for roads and other vehicles, see Regulation 80 of the MOQO Regulations.

The responsible person should develop the PHMP in the context of the entire HSMS. This will help identify gaps and overlaps when putting control measures in place for roads and other vehicles.

There will likely be some similarities between this PHMP and your mechanical engineering control plan.

8.3 Design and layout of roads

Every site is different and likely to present different hazards and risks. However, a well-designed and maintained site with suitable separation of vehicles and people will make vehicle accidents less likely.

You must eliminate risks so far as is reasonably practicable. If the risks cannot be eliminated, you must minimise them, so far as is reasonably practicable. The risk of pedestrians and vehicles interacting should be eliminated and, if not reasonably practicable, minimised. The most effective way to achieve this is to provide separate pedestrian and vehicle routes and, where practicable, keep light and heavy vehicles separate.

The life of the operation and future extraction designs should be considered when determining durability, size and maintainability of the roads. Locating roads in places that will not be impacted by future activity avoids rebuilding costs.

Terrain and geotechnical considerations

When designing and establishing roads, consider the terrain and geotechnical issues. They will affect the type of operation, the mobile plant used, and where infrastructure can be located.

With a geotechnical report and advice from a competent person, you can determine the best locations for roads, extractions and processing areas.

Operational parameters

Before construction, consider how operating parameters affect the design, layout, materials and maintenance requirements of the road. These parameters include:

- the vehicle manufacturer's recommendations for the use of each vehicle
- the characteristics of the vehicle and the type of load that will use the road
- expected traffic volume
- operating hours
- setting vehicle operating speed limits in conjunction with windrow design
- gradients (including super-elevation)
- road camber
- materials available for road construction and maintenance
- typical weather conditions.

Autonomous mining equipment

Careful planning is needed when using autonomous equipment, particularly the interaction between machines, people and the environment.

For more information, see the *ISO 17757 Earth-moving machinery and mining* standard. The following guidelines from Global Mining Guidelines Group may also be useful [Guideline for the Implementation of Autonomous Systems in Mining - Version 2 - Global Mining Guidelines Group](#)

Design of roads

Design roads that are:

- adequate for the number, type and size of the largest vehicles that may use them
- suitable for various driver positions including height and cab position (for example, right, left or centre position).

Roads should:

- be constructed with suitable material to provide firm surfaces, adequate drainage and safe profiles to allow for safe vehicle movements
- be clearly signposted including speed limits and radio telephone call point areas
- where appropriate, have edge protection and road markings (for example, sealed roads) or delineators showing the right of way
- have speed limits and speed control measures specific to site conditions and the types of vehicles using the route
- have adequate protection against rockfalls (for example, a catch ditch, catch bench or suitable barrier)

- be clearly delineated when it is dark, by using lighting, reflective marker pegs or similar devices, or have suitable access restrictions to hazards (for example, ponds or other water-filled hazards or steep drop-offs)
- allow for back break of the bench crest during the life of the road, as this may cause risks to stability near the crest. The amount of back break will depend on the geotechnical characteristics of the bench
- use one-way systems and turning points to minimise the need for reversing
- accommodate the turning circles of vehicles likely to use the road.

Also consider:

- access to the site including weight restrictions on bridges and narrow roads
- height limitations for traversing under overhead structures
- where distribution points will be (for example, processing areas, weighbridge locations, load covering areas, loading areas, points of sale to the public)
- the impact of land adjacent to the road (for example seepage from adjacent wetlands).

Where reasonably practicable, haul road design should avoid:

- office facilities and parking areas for light vehicles
- unstable areas
- hazards such as excavations, ponds, structures, fuel or chemical storage areas, underground working or voids, and overhead power lines
- steep gradients and tight bends
- one-lane two-way routes.

You may need to consult a specialist traffic engineer for complex traffic flows, especially at sites with large processing operations.

Road widths

The width of a road should be based on the size of the largest vehicle in use. The larger the vehicle, the more clearance is needed.

Each lane of travel should be at least 1.5 times the width of the widest vehicle or mobile plant that would normally use the road. For a two-lane road, the width should be at least three times the width of the largest vehicle. Provide extra room for drains, windrows or centre windrows. See Figure 17 for an example of this.

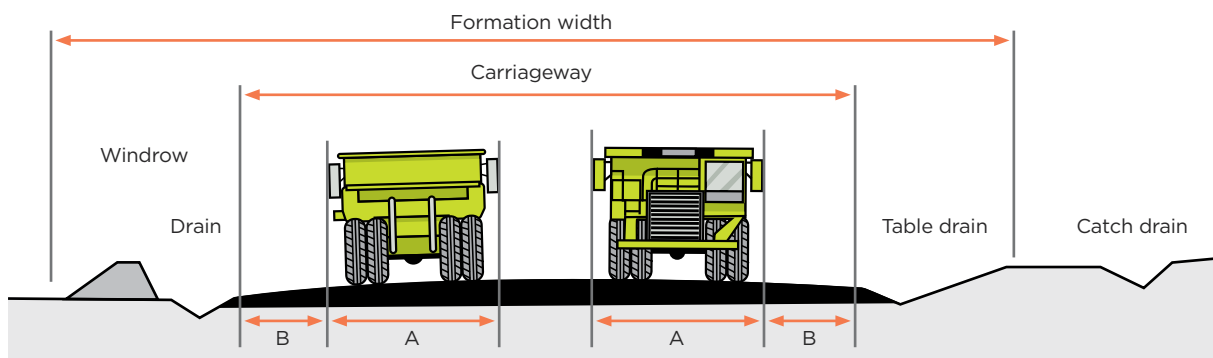

A = Width of widest truck using road
B = Half width of widest truck

FIGURE 17: Example of road layout with clearance between lanes

If it is not reasonably practicable to have two-lane roads, provide adequate passing bays and turning points. One-lane roads and turning points are not recommended on haul roads.

It may be appropriate to use turning bays to allow vehicles to turn and drive forwards most of the time. Turning bays would ideally be a roundabout or a 'banjo' type, although 'hammerhead' and 'stub' arrangements may be acceptable, see Figure 18 for examples.

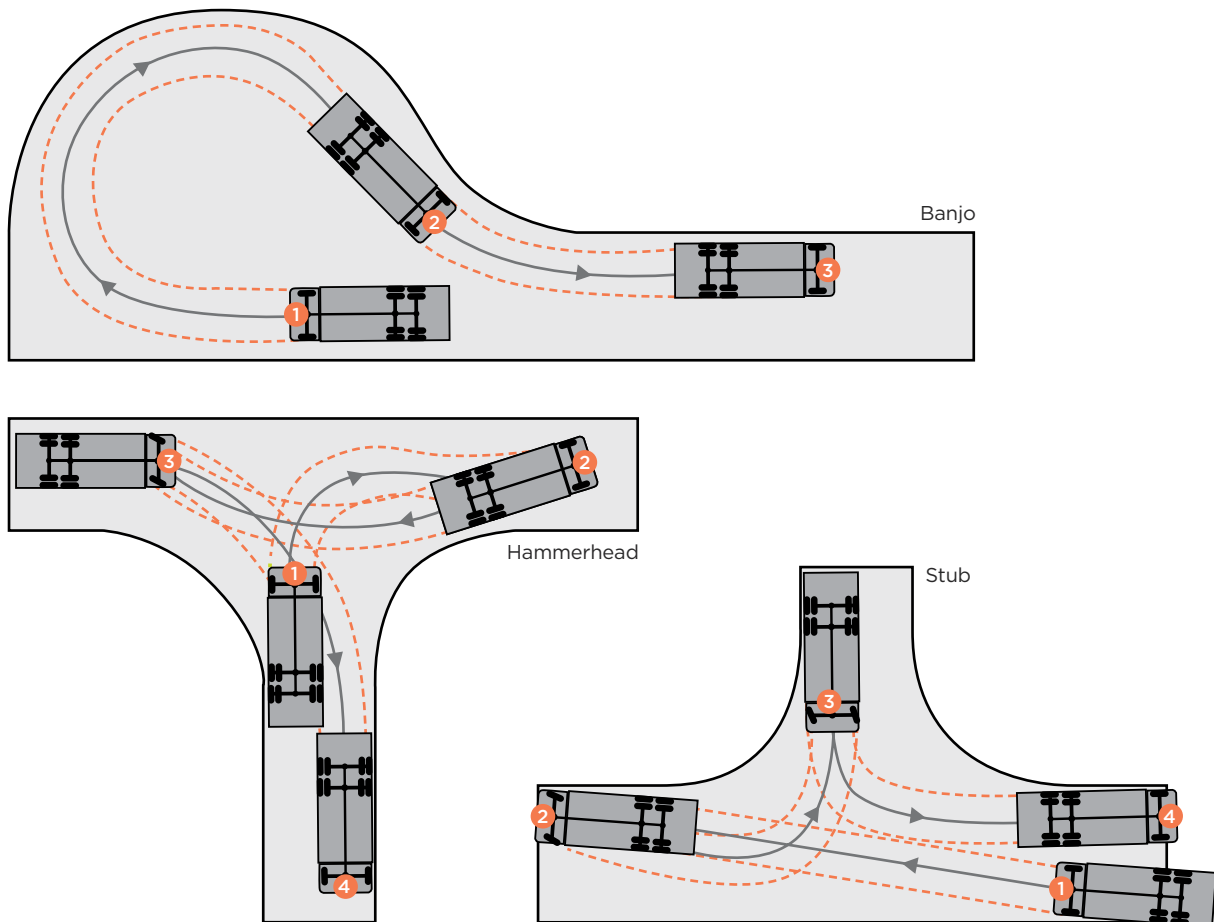

FIGURE 18: Turning arrangements

Where reasonably practicable, interactions between light and heavy vehicles should be eliminated. Do this by providing segregation of light vehicle on roads also used by off road dump trucks.

Where elimination is not reasonably practicable, minimise interactions between light and heavy vehicles using the following control measures:

1. Separation (different haul road).
2. Segregation (bund separation on the same haul road). See Figure 19.
3. Administrative control measures (for example, traffic lights or boom gates).

Consider the interactions of light and heavy vehicles when entering and leaving haul roads.

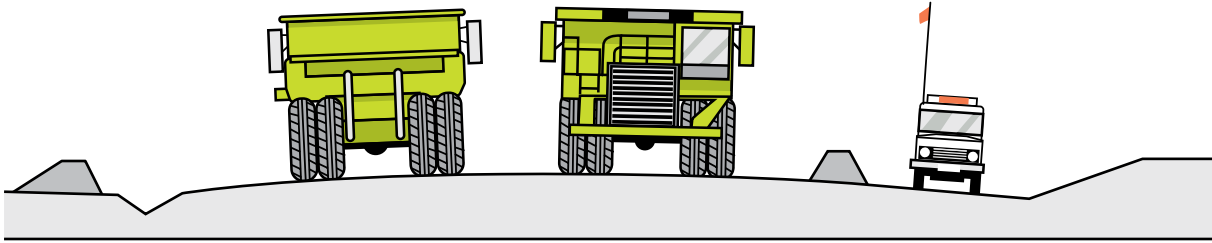

FIGURE 19: Segregation of light vehicles

Bends on haul roads should be designed wider than the straight stretch to allow for the overhang of vehicles using it.

Switchbacks or other areas on haul roads requiring sharp curves should be designed to take into account the minimum turning radius of the haul trucks.

Road gradient

Important aspects of the steepness or grade of a roadway include:

- compatibility with the braking capabilities of the vehicles (with a factor of safety)
- compatibility with the performance capabilities of the vehicles
- effect on a vehicle's stopping distance
- ability of a vehicle to operate safely in wet conditions
- speed around bends, which is affected by super-elevation.

DETERMINING THE GRADE OF A ROAD

The steepness of a road is normally expressed as a ratio which is determined by measuring the distance travelled along the road in relation to the vertical height change (see Figure 20). For example, a road with a 1m vertical change over a travelling distance of 10m has a ratio of 1:10.

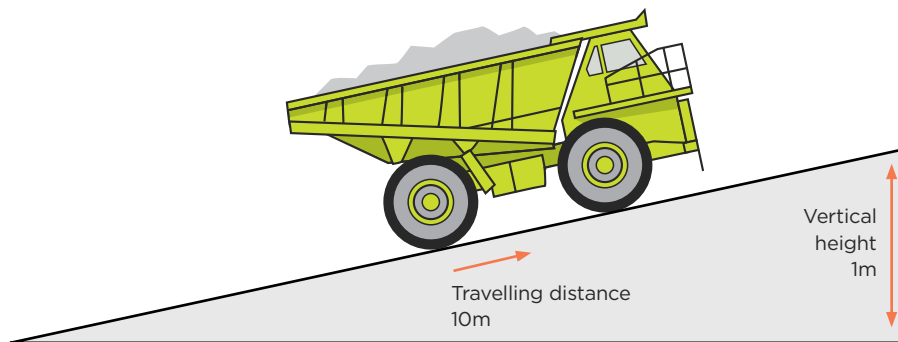

FIGURE 20:
Road gradient

Information in vehicle manuals about braking and performance abilities on slopes may be provided as a grade percentage (see Figure 21).

The steepness of a road should be measured using surveying equipment. The grade should be determined over a portion of the road where the grade is constant. Where the steepness varies, the grades should be determined for different segments.

The orange numbers on the right are angles in degrees. The numbers in black show the angle expressed as a ratio and a grade. For example, a '1 in 4' slope is a 25% grade.

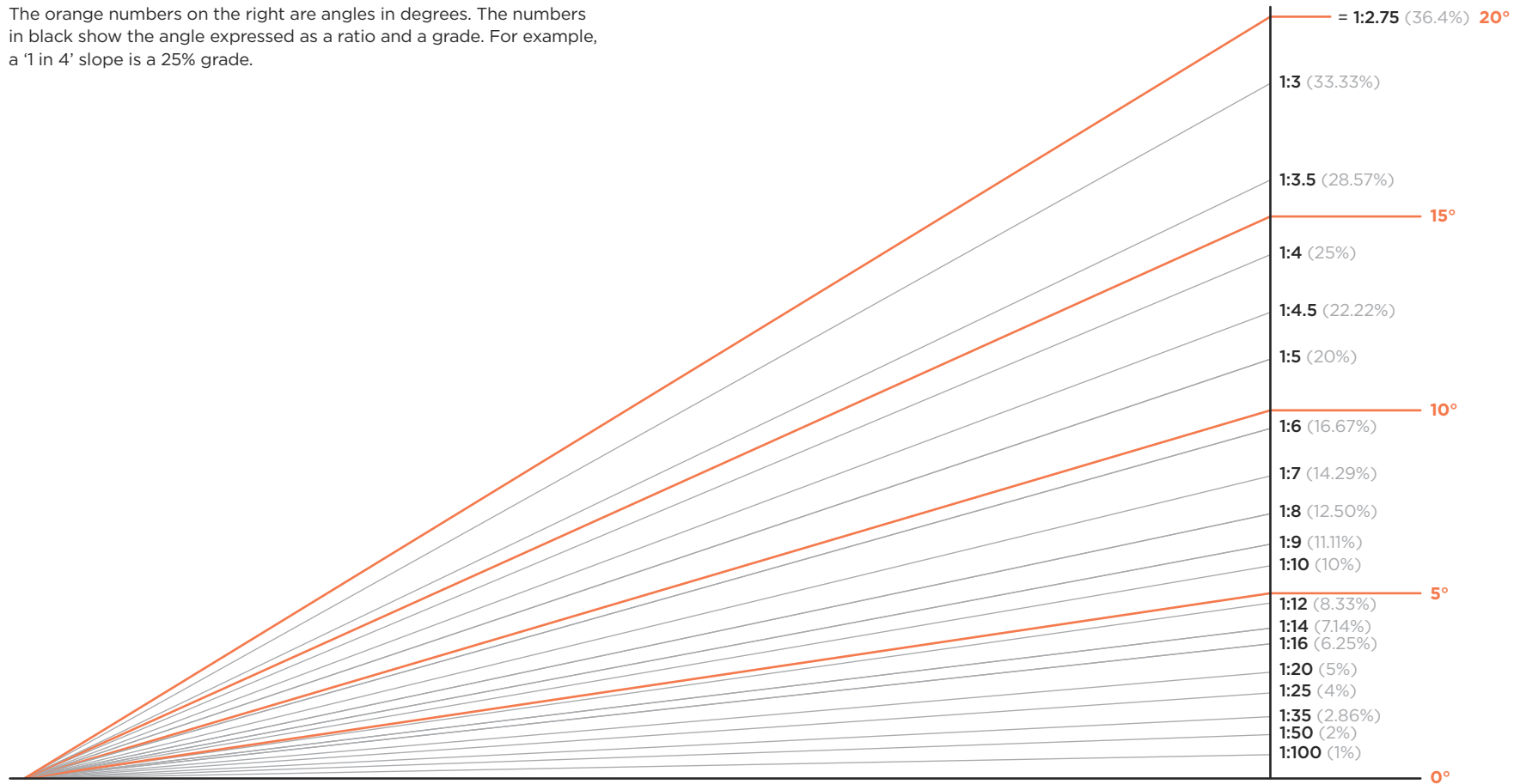

FIGURE 21: Ratio to percentage grade conversion

GRADE AND VEHICLE COMPATIBILITY

The grade of a road should be compatible with road conditions, the type of road surface and the vehicle capability. Vehicle brakes should be able to stop in the worst-case scenario without losing control of the vehicle. Particular attention should be paid when loads are moved downhill.

Different vehicles with different performance characteristics will use the roads. Roads should be designed to allow all vehicles to operate within their safety parameters. Road grades should never be designed to the maximum climbing or descending capacity of the vehicles that use them.

It is important vehicles are not overloaded as brake or retarder performances depend on the grade and the vehicle's total weight (see Section 14.6).

GRADE SITUATIONS TO AVOID

Avoid road alignments that result in a sharp bend near the top of a grade. These are hard to see at night, when headlights tend to shine up into the darkness. If this cannot be avoided, the bend should be defined, for example, by using extended reflective markers.

Also avoid sharp bends near the bottom of a grade. Here, vehicles tend to pick up momentum, making it more difficult to maintain control around the bend. If you cannot avoid a sharp bend, a safe speed for descending the grade should be posted and adequate restraining measures such as large windrows or runaway provisions should be used.

SUPER-ELEVATION

Super-elevation is the banking of the road pavement at bends. It can assist vehicles to manoeuvre safely around corners. It allows the vehicle taking the corner to counteract forces towards the outside of the bend, by directing the vehicle's weight towards the centre, or radius, of the bend. The amount of super-elevation on a bend is directly related to the radius of the corner and the desired vehicle speed through the corner.

Table 6 is a guide for providing the super-elevation necessary to reduce lateral forces. The maximum super-elevation should be regarded as 1:20.

TURN RADIUS (m)	Speed (km/hr)			
	16	24	32	40
45	1:25			
60	1:37.5			
90	1:50	1:20		
150	1:100	1:37.5	1:20	
215	1:100	1:50	1:25	
300	1:100	1:50	1:37.5	1:25

TABLE 6:
Recommended
super-elevation

Super-elevation is an important design consideration for switchbacks on haul roads as they typically have a small turn radius. On switchbacks, which have the centre of the bend located on the up-side of the road, a well-chosen super-elevation rate prevents material being spilled from laden trucks and improves vehicle control.

As with changes in grade, transition into and out of super-elevated bends should be smooth so vehicles can be eased into corners. Super-elevation transition lengths depend on the cross-fall change and the design speeds. The larger the change in road alignment, the longer the transition should be. Transition lengths should be applied so that one-third is on the bend and two-thirds are on the tangents (see Figure 22). Table 7 outlines the recommended lengths.

VEHICLE SPEED (km/hr)	16	24	32	40	48	56
Cross slope change per 100m pavement	0.08m	0.08m	0.08m	0.07m	0.06m	0.05m

TABLE 7:
Recommended transition lengths

Example of how to use this table

Assume a vehicle is travelling at 32km/hr on normal pavement with a cross-fall of 2%. The vehicle is approaching a switchback with super-elevation of 4% the opposite way. The total cross slope change here is 6% (2% plus 4%). For a vehicle travelling at 32km/hr, the recommended change is 0.08m per 100m. Therefore, the total transition length is 75m ((6%/0.08m) x 100 = 75m).

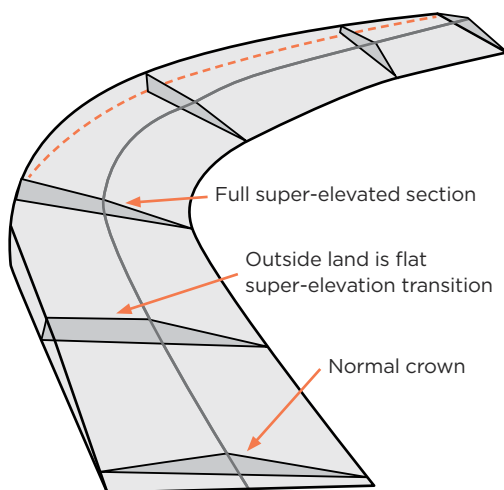
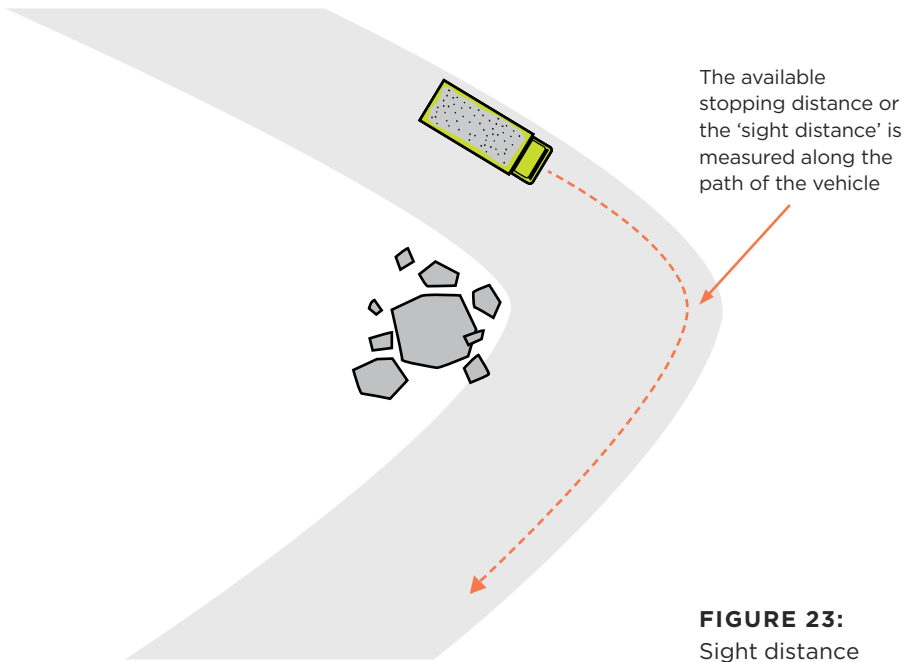

FIGURE 22:
Super-elevated bends

Sight distance

Sight distance is how far along the road a driver can see ahead of their vehicle (see Figure 23). Roads should be designed to give drivers a sufficient distance of clear vision ahead to avoid unexpected obstacles. At intersections, consider the windrow design to ensure good visibility. A basic rule of safe driving is that, at all times, a driver should be able to stop the vehicle within their sight distance. If a driver sees a problem, such as a boulder on the road or a stalled vehicle, they should be able to stop in time to avoid it.



Roads should be designed with viewing distances and alignments. This ensures that a vehicle rounding a bend, cresting a hill, descending a grade, or approaching a junction can stop in time to avoid an obstacle or another vehicle pulling onto the road (see Figure 24). Consider the seated height of a driver in different vehicles.

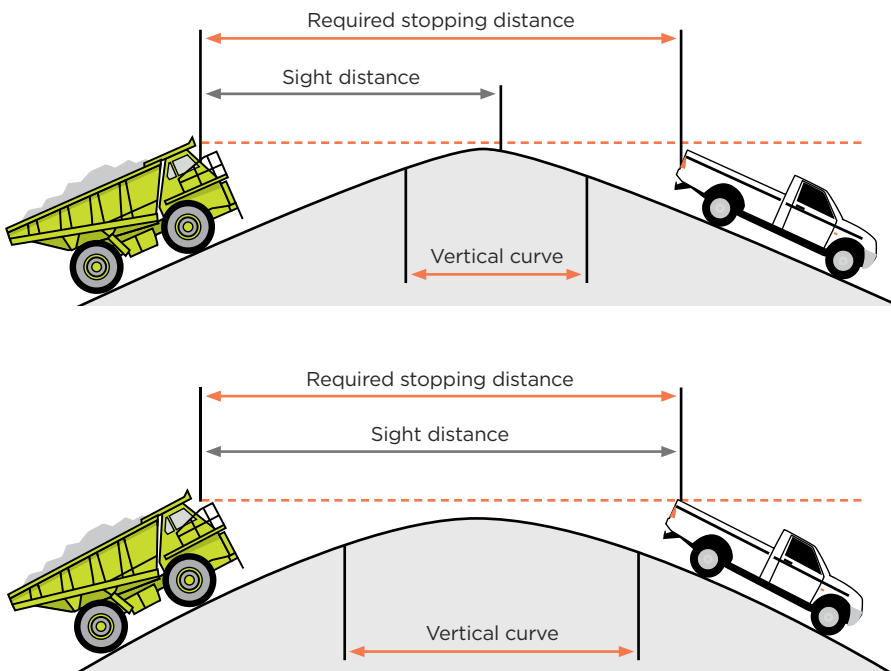

SIGHT DISTANCE IN BAD WEATHER OR AFTER DARK

Sight distance can be reduced during inclement weather such as rain, snow or fog. In these conditions, drivers should slow down enough to stop within the available sight distance. Effective headlights, flashing beacons and spotlights improve the ability to see and be seen.

When driving after dark, sight distance can be defined by the distance illuminated by the vehicle's headlights. Drivers should reduce their speed so they can bring the vehicle to a stop within the illuminated distance. This distance will vary with the type of headlight. To be most effective, headlights should be kept properly aimed and clean. Speed should be reduced at night because drivers typically have reduced depth perception, peripheral vision and reaction times.

There is often little contrast in brightness between the background and other objects at an extractives site, especially in snow. Roadside reflectors should be installed to help define the roadway and intersections. Vehicles used at night should have lights that can be seen from the side of the vehicle, as well as the front and rear.

SIGHT DISTANCE AT INTERSECTIONS

Sight distance is important at intersections. A driver should be able to see oncoming vehicles far enough away to safely turn onto or cross the road. Ideally, drivers should be able to pull onto the road, or cross the road, without requiring approaching vehicles to slow down. The main factors in the safe sight distance at intersections are the acceleration ability of the vehicles pulling onto the road and the speed of the oncoming traffic.

Because of the limited acceleration ability of trucks, especially when laden, ample sight distance should be provided. The higher the speed on the road, the longer the sight distance should be.

Avoid locating intersections near hill crests or sharp curves. In these situations, sight distance will be limited. Intersections should be kept as flat as possible and sight distance should be considered in all directions.

In laying out intersections, consider the effect of the large blind spot to the right or left side of haulage trucks (depending on the position of the driver's seat). Intersections where trucks need to stop or give way to other vehicles should be angled to optimise the driver's ability to see vehicles coming from both the right and left sides (see Figures 25 and 26).

For roads used by haulage trucks, avoid roads that intersect at an angle of less than 90° on the opposite side of the driver. Alternatively compensating measures should be taken (for example, convex mirrors, reduced speed zones, communication systems or on-board cameras).

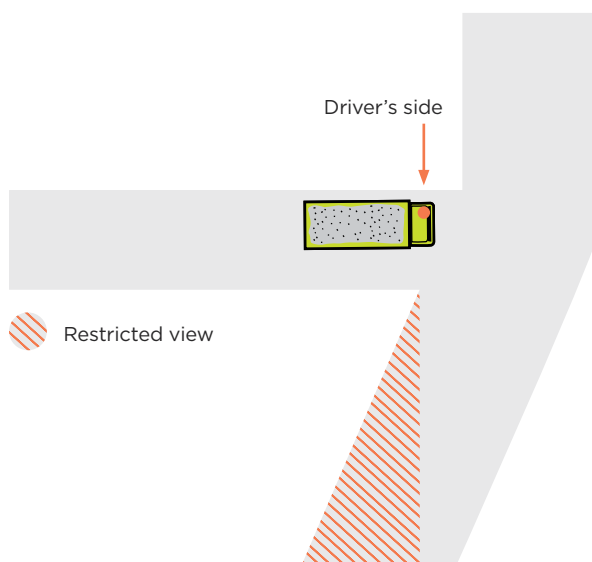
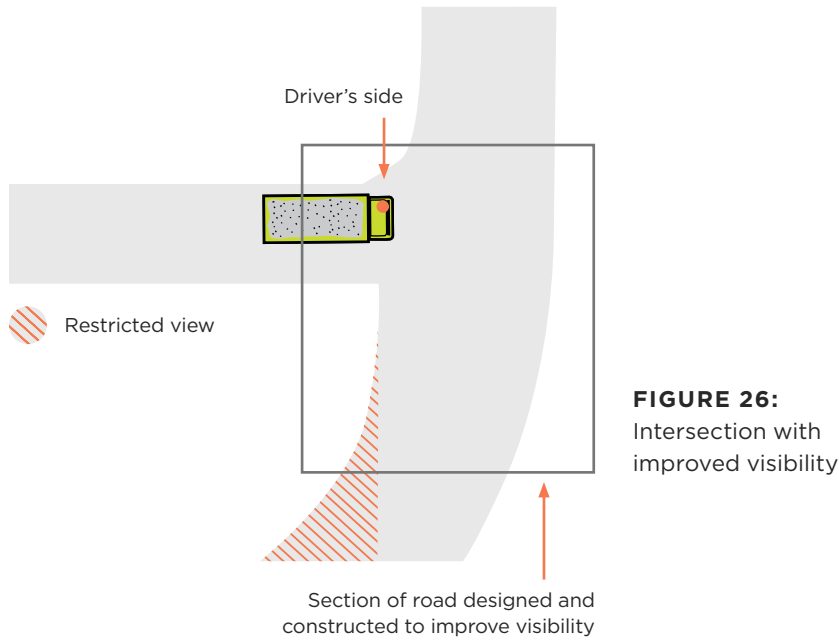
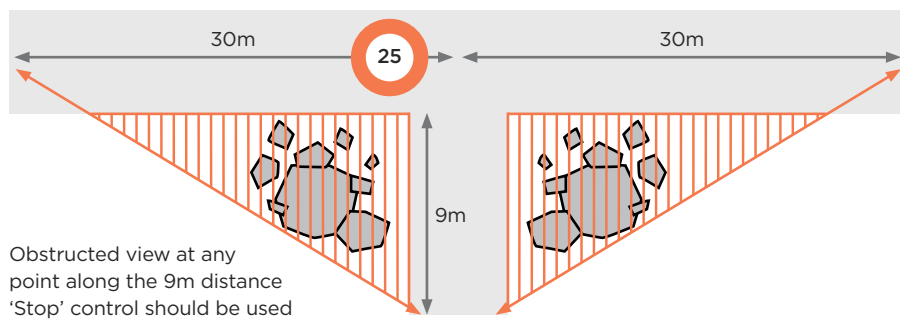
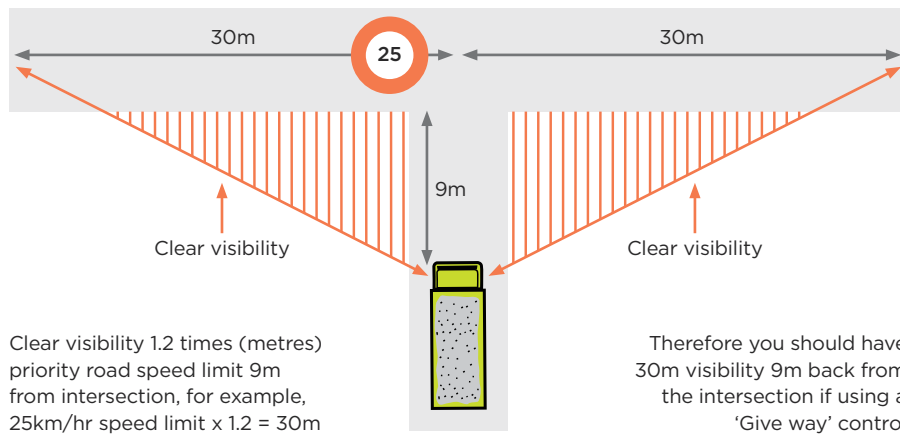

FIGURE 25:
Intersection with
restricted view



When using 'give way' controls at an intersection, there should be visibility clearance of 1.2 times the priority road speed limit, 9m back from the intersection (see Figure 27). Where this is not possible, a 'stop' control should be used that requires vehicles to come to a complete stop (see Figure 28).



Drainage

Having good drainage systems will:

- prolong the life of the road
- reduce maintenance costs on roads and vehicles
- minimise downtime
- minimise adverse health effects on drivers
- improve tyre life.

Drainage is generally provided using the following:

CROSS FALL (OR CROSS SLOPE)

Surface drainage is designed to cause the water to leave the road as shallow, non-erosive sheet flow in a way suited to the road material, slope and terrain. To promote drainage, either the road surface should be sloped from one side to the other, or the road should be crowned (or raised) in the centre.

Typical cross-falls for unpaved roads in New Zealand are 3.5% to 4% and 2% to 4% for paved roads. On haul roads, a cross-fall between 2% and 4% is preferred. Steeper crowns can increase tyre wear and metal fatigue in trucks. Cross-falls should not be carried around a bend. Instead, there should be a transition zone between the normal cross-fall road and the start of the super-elevation of the bend.

FREE-DRAINING ROAD MATERIALS

These allow water on the road surface to drain down and out.

ROADSIDE DITCHES

These collect drainage from the road surface and intercept runoff from adjacent hillsides.

CULVERTS

Culverts carry runoff under the road surface to a drainage course. They vary in size from 300mm concrete or corrugated metal pipes to large shapes 3m or more in diameter. The inlets and outlets for the larger sections usually have concrete headwalls and wing walls to reduce erosion. The smaller pipes usually have bevelled end sections for the same reason.

Culverts should be buried deep enough to prevent them being crushed by vehicles passing over them. Manufacturers can provide information about suitable depth.

Unless the culverts lead to additional diversionary ditching, provide water run-outs to reduce the velocity to where the water is non-erosive. On shallow slopes (less than 10%) with limited water flows (<0.5m/s), this can be done with vegetated outflow areas. Energy dissipaters (riprap or tipped rock) may be required where flow rates are higher.

Provide and maintain good drainage to make sure low water levels in the road fill in areas of a naturally occurring high water table (for example, swamps or watercourses).

Temporary in-pit roads with high ground water levels can be improved by placing gravel or rockfill over the area, or by installing pumping wells to lower the water table. Pumping wells may be cost effective if they also reduce the water level in, and improves the stability of, the working area.

Make drainage features large enough, and space them apart so they can handle the greatest expected demands on them.

During or right after rain is a good time to check that drainage is working properly.

Road pavement

Surface and drain all roads adequately to make sure vehicles can be driven safely.

The materials that make up the road pavement and road base should provide:

- adequate traction
- support for vehicles without excessive sinking or rutting.

TRACTION

A road pavement of gravel or crushed stone is preferred. While some other materials provide better traction when dry, a gravel road pavement offers good traction in wet and dry conditions.

You may have to import gravel or crushed stone if it is not available on site. Alternatively, if all weather pavements are not practicable and roads become untrafficable due to weather or underfoot conditions, you should have procedures that outline when operations should stop and restart. For example, a Trigger Action Response Plan (TARP). You should base these procedures on technically sound risk assessments.

The forces required for accelerating, turning, or stopping vehicles are caused by the friction generated between the tyres and the road pavement. The amount of friction available varies with different road pavements and is indicated by a friction coefficient, which is a measure of how well the tyre grips the road pavement.

The friction coefficient indicates how much of the total weight of the vehicle can be generated as a force between the tyre and the road pavement. The higher this force, the better the grip on the road and the more control the driver has in climbing, steering and stopping.

Table 8 shows some typical friction coefficients for different road pavements. Notice the significant differences in values, varying from concrete (0.9) down to ice, which can be practically zero. The value of 0.9 for rubber tyres on concrete means 90% of the weight on a tyre is available as braking force (assuming the brake components themselves can provide this much braking force).

PAVEMENT MATERIAL	DRY	WET
Clay	0.60–0.90	0.10–0.30
Concrete	0.90	0.60–0.80
Gravel road, firm	0.50–0.80	0.30–0.60
Gravel road, loose	0.20–0.40	0.30–0.50
Ice	0.00	0.00
Sand, loose	0.10–0.20	0.10–0.40
Snow, packed	0.10–0.40	0.00

TABLE 8:
Typical friction coefficients for road pavements

The different values show how important it is that drivers adjust their speed to suit the road conditions. All other factors being equal, it will take a longer distance to stop when traction is low. If the friction coefficient is reduced by half, the stopping distance is doubled once the brakes are applied. Friction values also affect steering ability. Reduce speed when traction is low.

The road pavement coefficients given in Table 8 are the maximum values for the indicated conditions. Maximum tyre grip occurs when the tyre is still rolling and just before the tyre would lockup and slide. Once a tyre locks up and goes into a skid, the available friction is reduced. This reduction can be as much as 50% under poor road conditions. This is why antilock brakes are so beneficial. They help prevent tyres from locking up, so the available friction remains high. Brakes stop the wheel, but it is the grip between tyre and road pavement that stops the vehicle.

SUPPORT

Rutting of a soft pavement can create a hazard by affecting a driver's ability to control their vehicle and exposing them to rough or jarring conditions. Rutting occurs when tyres sink into the pavement because the road pavement does not offer adequate support. Fine-grained soils, even when well-compacted, may not support the tyre loads imposed by large haul trucks, especially in wet conditions.

To eliminate or minimise rutting, a road base material should have sufficient strength to support tyre loadings. A layer of gravel or crushed stone, for example, has higher bearing strength and will distribute the tyre loadings over a larger area. A layer of geotextile can help provide a road base with good support for tyre loadings. If a road base is not strong enough to support tyre loadings, the road will need a lot of maintenance to keep it in good condition.

Roadside edge protection

Edge protection helps protect drivers and others at risk if a vehicle leaves the road.

Provide adequate windrows or guardrails where there is a change of level, drop, pond or any other hazard.

Roadside windrows are a common safety feature along elevated roadways.

Windrows help:

- the driver see the edge of a roadway
- give the driver a sense of contact if the vehicle makes contact with them
- restrain an out-of-control vehicle, allowing the driver to regain control and keep it from leaving the road
- keep a vehicle away from the edge of the roadway by a distance equal to at least the width of the windrow.

Windrows on roads should be of sufficient height and width, constructed with suitable material, and be steeper on the roadside.

EARTHEN WINDROWS

Windrows are often built of earthen material and need to be designed and constructed to a pre-determined standard to be effective. Their suitability depends on factors such as height, width (or thickness) and firmness.

In some cases, windrows that are half the wheel height of the largest vehicle may be too low to prevent certain vehicles from going off course. For example, an articulated dump truck travelling 30km/h may require a windrow at least 66% of its wheel height to be redirected back onto the intended route (see Figure 29). The shape and width of the windrow also plays a crucial role (see Figure 30).

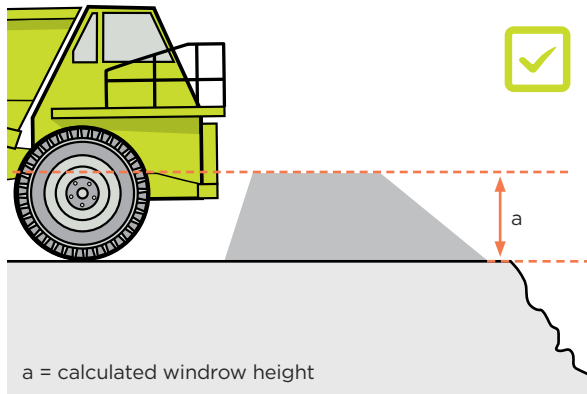

FIGURE 29:
Suitable windrow
- firm material big
enough to absorb the
vehicle's momentum
with a steepened
inside slope

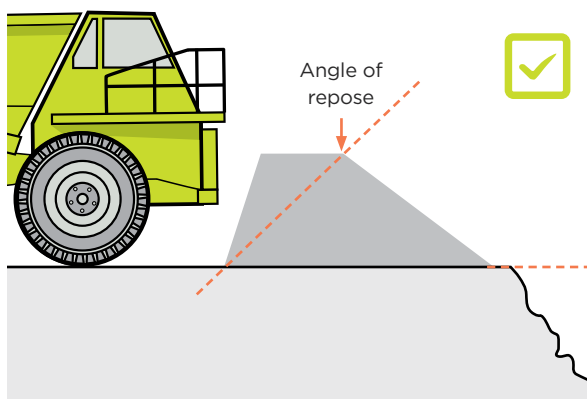

FIGURE 30:
Suitable windrow
- the width of the
windrow is as wide
as the normal angle
of repose

Windrows that are too low or have curved slopes can act as ramps, making them ineffective. Before installing or constructing windrows, consult a competent person for advice.

When designing windrows, consider:

- the type of vehicle, for example rigid or articulated
- the mass of the vehicle
- the operating speed of the vehicle
- the size of the tyres
- where the vehicle is required to operate
- the type of material available to build the bund.

Windrows can deteriorate due to weathering and should be regularly inspected and maintained to make sure they continue to be effective. This should be done as part of the manager's daily site inspection.

CONSTRUCTING WINDROWS

One way for a windrow to provide restraint is by deflecting the tyre and redirecting the vehicle back onto the road. To do this, make the windrow material firm, and the inside slope as nearly vertical as possible (a slope greater than 40° is recommended). When cutting the inside slope to steepen the windrow, make sure enough material is initially placed so, once the windrow is acute, the base width is still adequate. Make the base width at least the width the windrow would have been if both its outside and inside slopes were at the material's angle of repose. Maintain a full base width to serve the function of keeping vehicles back from the edge.

Windrows constructed of broken rock mixed with bonding materials will normally provide restraint due to the interlocking and frictional resistance of the rock pieces. If a windrow is too loose, it will provide little restraint, and the vehicle may plough straight through it. If a windrow is firm, but is not steep on the roadway side, the vehicle could ride up and over it.

A windrow can also impede the passage of a vehicle by a combination of the tyre sinking into and raising up as it climbs the windrow material. The vehicle may get bogged down as it ploughs through. To effectively impede a vehicle in this way, a windrow should generally be larger than axle height. In general, when finer materials are used, less effort is made to compact and shape a windrow, so the windrow should be larger to provide similar restraint.

If there is significant risk that mobile plant could breach windrows, consider having more substantial windrows. For example, the typical axle-height berms might not be enough to stop large and heavy vehicles. Windrows much larger than axle-height are required to completely stop a vehicle for all possible conditions of speed and impact. For vehicles under 85t, windrows should be constructed to a height three times the axle height. For vehicles over 85t, windrows should be constructed to a height four times their axle-height. This is based on a vehicle contacting the windrow at 48km/hr at a 30° angle of contact.

The amount of restraint offered by a windrow depends on the conditions under which the vehicle hits it. The greater the vehicle speed, or the more head-on the vehicle contacts the windrow, the larger the windrows have to be. Use larger than typical windrows in areas where it is reasonable to expect more adverse conditions, such as where vehicles would have more speed or would contact the windrow head-on. For example, where there is a curve at the bottom of a grade. In these cases, increase the windrow size or consider other provisions, such as runaway lanes or double windrows.

Make roads wide enough so windrows are constructed on a firm foundation that is level with the roadway (see Figure 31). If the road width is inadequate and a portion of the windrow extends over the hillside, the windrow will be more likely to give way when hit and offer little restraint.

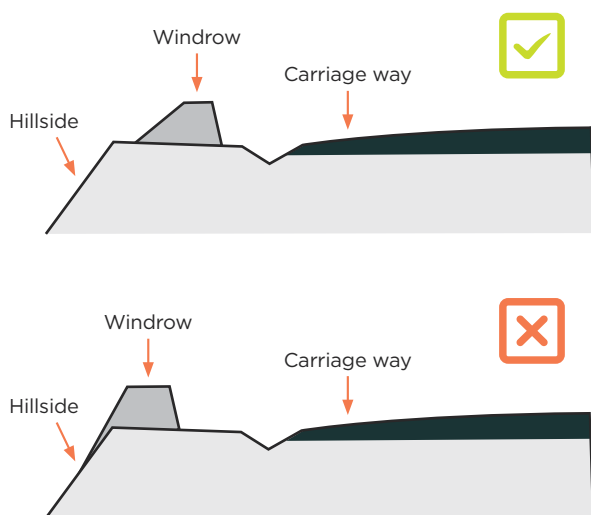

FIGURE 31:
Windrow constructed
on firm foundation

Leave gaps in the windrow or other drainage systems provided where necessary, to allow drainage of surface water (see Figure 32). Make sure any gaps are not wide enough for a vehicle to pass through. Design them so a vehicle's wheel cannot be trapped at an angle leading away from the travelling direction.

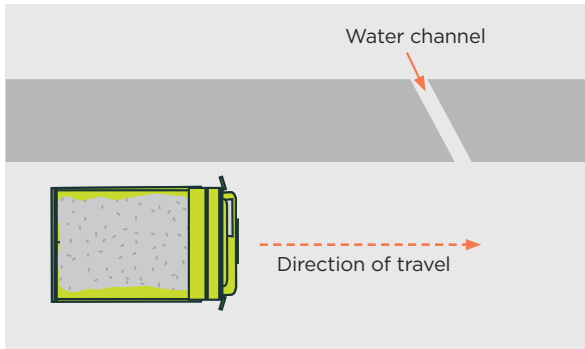

FIGURE 32:
Suitable windrow – gaps
in windrow for drainage

Boulder windrows

Sometimes a continuous row of boulders is used to form a windrow. When a vehicle hits a boulder windrow, the restraint comes from the frictional forces involved in sliding the boulder ahead of the vehicle.

Boulders cannot be placed right at the edge of the drop off because there has to be a distance available for the vehicle to push the boulders. This distance will depend on the size of the boulders and the size and speed of the vehicle.

For that reason, stone blocks or tyres placed individually along the edge of a road, which can be easily pushed out of the way by a vehicle or increase the risk of injury to the driver, are not suitable for windrows (see Figure 33).

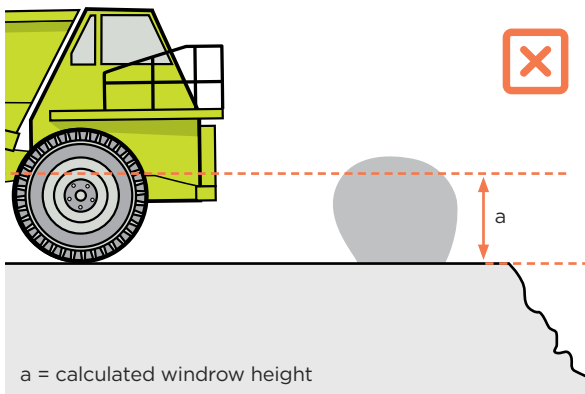

FIGURE 33:
Unsuitable edge
protection – blocks of
stone can be pushed
out of the way

Blocks of stone or tyres may be used, provided you heap materials (such as scalplings) between the blocks or tyres so they can safely absorb the impact of a vehicle and will not be easily pushed (see Figure 34).

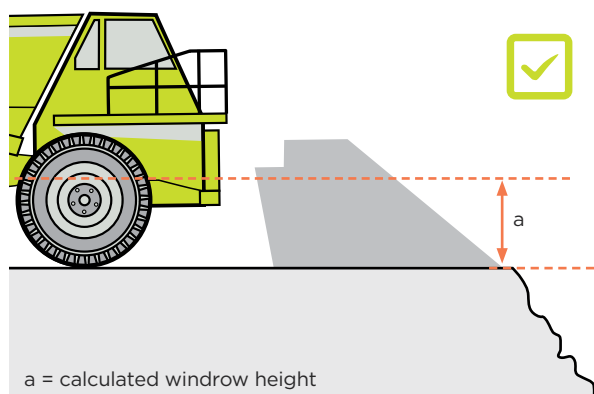

FIGURE 34:
Suitable edge protection
– a rock with material
in between which can
safely absorb the impact

Guardrails

When using guardrails instead of windrows, they should:

- clearly indicate the edge of the road
- give the driver a sensation of contact if they accidentally hit the guardrail
- deflect the vehicle back onto the road
- prevent the vehicle from driving over the edge.

Consult a qualified engineer with suitable experience to determine the adequate design and construction of guardrails.

Because of the large size and mass of haul trucks, guardrails generally need to be higher and stronger than those typically used on public roads.

Embed guardrails deep enough to provide adequate resistance. Guardrails should be strong enough to stop or deflect the vehicle back onto the roadway.

Installation and use should not exceed the manufacturer's recommended limits in respect to vehicle type, size and weight.

Keep guardrails easy to see by adding reflective material. This helps drivers spot them at night and recognise them as edge barriers.

Control measures for runaway vehicles

Safety features should be incorporated into road design to control runaway vehicles. Typical edge-of-road windrows alone should not be relied on to stop a large haul truck. Other methods such as centre berms and escape lanes can bring a runaway vehicle to a safe stop and prevent a more serious outcome.

Centre berms are piles of loose granular material placed strategically along the centreline of the road (Figure 35). In the case of brake or retarder failure, the driver manoeuvres the vehicle in line with the berm, so the vehicle straddles the berm and is brought to a halt.

When installing centre berms, consider:

- the nature and size of the laden weight of the vehicle that might need to be driven onto or straddle the centre berm
- using material that provides sufficient drag on the vehicle
- positioning the centre berms so that vehicles have limited time to pick up speed
- allowing adequate space between berms so that the driver has time to position the vehicle.

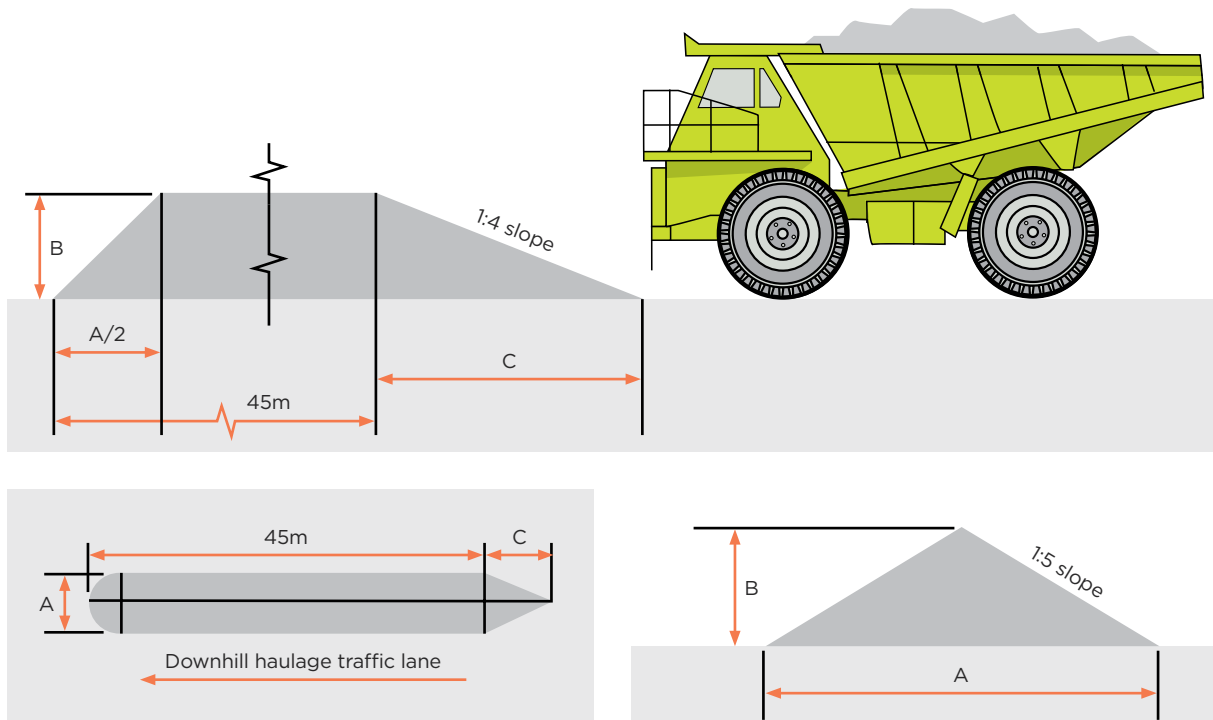

GROSS VEHICLE WEIGHT	A	B	C
Less than 45,000kg	3.5m	1-1.2m	4.5-5m
45,000-91,000kg	3.5-4.5m	1.2-1.5m	5-6m
91,000-181,000kg	4.5-5.5m	1.5-1.8m	6-7m
More than 181,000kg	5.5-10m	1.8-3.5m	7-13m

FIGURE 35: Runaway vehicle centre berm

When installing escape lanes, consider:

- the size and expected speed of a laden runaway vehicle that might enter the lane
- alignment of the lane and the road
- that the driver of the runaway vehicle should be able to steer it into the lane
- the size and length of the lane. The lane needs to be wide enough and long enough to allow vehicle access and time for it to slow and stop
- that the lane should be constructed of material that offers a high rolling resistance that will not compact (for example, loose gravel or crushed aggregate).

For examples, see Figures 36 and 37.

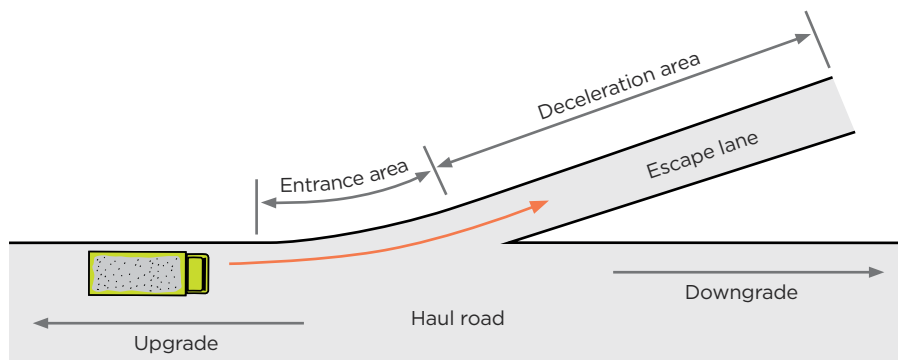

FIGURE 36:
Plan view - haul road
escape lane

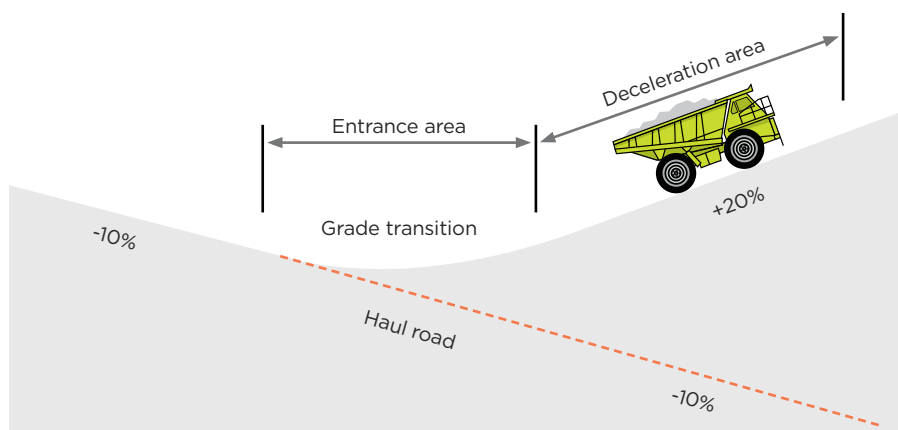

FIGURE 37:
Profile view - haul road
escape lane

Parking areas

When establishing parking areas, consider:

- separating pedestrians, and light and heavy vehicles, including private vehicles (for example, workers' cars)
- locating the parking area on flat ground if possible and avoid locations where buildings, such as offices, could be struck by vehicles
- using consistent design and layout
- using one-way systems to limit the need for reversing
- using stop blocks or spoon drains to prevent unintended vehicle movement
- having clear signs.

For more information see Section 14.5.

Tips or stockpiles

When establishing tips or stockpiles, think about the vehicle activities that will occur in these areas and set up control measures to manage the risks. For example:

- ensure sufficient room for vehicles to operate
- use one-way systems where possible
- manage stockpiles so they do not encroach on vehicle operating areas or restrict drivers' lateral vision
- restrict access for light vehicles and pedestrians
- provide adequate lighting if operating at night.

For more information on tips and stockpiles, see Section 11.

Workshops and fixed plant areas

A vehicle collision with a pedestrian, machinery or another vehicle is much more likely in workshops and process plant areas due to the restricted vision around fixed plant and doorways. To reduce the risk of this occurring:

- provide specific parking areas
- restrict vehicle access as much as practicable
- have clearly marked pedestrian crossings and walkways
- install bollards or barriers to protect infrastructure close to roads
- set appropriate speed limits with clear signs
- locate workshops away from production areas and haul roads.

Ground instability hazards above and below roads

Road hazards can be created due to unstable material above or below the road. Rockfalls or slides of material onto the road could endanger passing vehicles.

Avoid constructing roads on unstable or weak ground (such as those constructed on fill areas) as they may not be strong enough to support the vehicles that use them. When building a road against a slope, plan for it to be wide enough to accommodate catch trenches or bunds that will protect workers from falling material.

Road design should account for the potential of slope failure due to water, slumping or erosion.

Pay attention to the stability of any area where water is seeping out of a slope – the presence of water tends to make slopes less stable. For more information on drainage and depressurisation and on slope hazards, see Section 6.7.

ROCKFALLS

Where roads are adjacent to any highwalls, slopes or tips containing large rocks, make sure vehicles are protected from potential rockfalls.

Rock slopes tend to become less stable over time due to factors such as weathering and the effects of water. Regularly check slopes for overhangs, open joints or other evidence of unstable rock. Unstable material should either be removed, supported, or the area isolated (for example, with catch bunds or rockfall fences) so drivers are not at risk of a potential rockfall.

Consider how high and how far out from the wall the structure must be if using catch bunds or rockfall fences. This will help prevent passing vehicles being exposed to the hazard by absorbing and dissipating the energy of the falling rock.

How far a piece of rock will fall from a wall depends mainly on the steepness of the wall and the presence and condition of any structures. With a vertical wall, a rockfall would tend to end up near the base of the wall. With a sloping wall, or a wall with benches that have a build-up of material on them, the falling material will tend to bounce and be propelled further out from the base of the wall.

Maintenance should include clearing slips or rockfalls that could reduce the catchment area if left to build up. For more information on ground support, see Section 6.8.

CUT AND FILL ROADS

Filled roads should be constructed in compacted, horizontal layers. When fill is placed on an existing slope, the layers should be tied in by first removing vegetation and cutting horizontal benches into the existing slope material. Any springs or seepage areas should be collected in a drain to prevent the fill becoming saturated. Repair eroded fill slopes before they become a risk to road users.

Watch for signs that the ground below the road may be unstable (for example, tension cracks or settling). Slopes may become unstable as they absorb rainfall, become eroded, or are loaded by the weight of heavy vehicles.

8.4 Traffic management plan

Regardless of the size of your site, you should produce a traffic management plan that identifies the risks associated with vehicle movements on site and how to control them.

Traffic management plans usually show vehicle routes, flow, access points, parking areas and other vehicle control areas such as assembly points.

The plan should include roads and other key features of your traffic management system. It will form part of your roads and other vehicle operating areas principal hazard management plan (PHMP) if you are a mining operation, A-grade quarry operation or an A-grade alluvial mining operation.

Update your traffic management plan to reflect changes at your site and communicate these changes to all workers and visitors, for example, during induction or toolbox talks, or at sign-in.

For more information on traffic management plans, see our [guidance Managing work site traffic](#)

Traffic signs and markings

Use signs (including delineators) and line markings for drivers and pedestrians, consistent with those used on public roads (where a suitable sign or marking exists). This is to ensure instructions are easily recognisable to drivers and pedestrians.

Keep signs clean to make sure they continue to be effective. Maintaining signs should form part of your road maintenance programme.

Use illuminated or reflective signs, markings or delineators where driving is likely to be carried out in the dark.

Use delineators suitable for the size of the largest vehicle using the road.

Consider taller delineators (road markers) in areas that receive snow to make sure they are always visible where snow can drift or where graders may otherwise bury them.

Signs could be used to inform drivers or pedestrians about the routes to use and how to behave safely (for example, whether they should use protective equipment, and how). See Figure 38.



FIGURE 38:
Example of sign helping arriving drivers know what to expect

Warning signs to show hazards along the way could also be appropriate. See Figure 39.

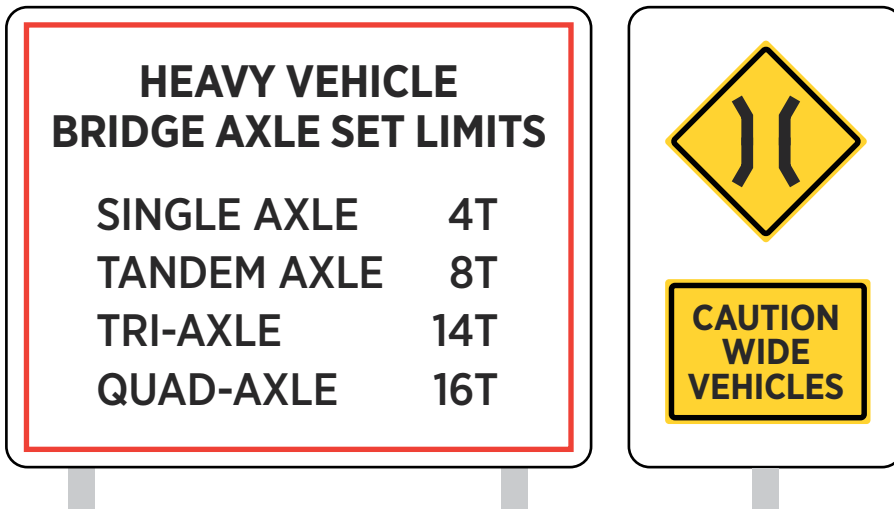

FIGURE 39:
Example of weight restriction sign and narrow bridge sign

Speed limits

Speed limits should be established based on a risk assessment carried out by a competent person. The assessment should consider the layout and condition of the roads, and the capabilities of the vehicles using the roads.

For any given section of a road, the speed limit should be the speed at which, under normal conditions, sight distances are adequate, curves can be safely negotiated, and any downgrades can be travelled without exceeding the vehicle's braking capabilities. Speed should be consistent with the width and smoothness of the road so the driver can drive safely with a reasonable level of comfort and control.

Speed limits should be set at a level that allows for changeable weather visibility conditions.

SPEED ON DOWNHILL SECTIONS

The speed limit posted on downhill sections should take into account the braking capabilities of the vehicles using the road.

On haul roads, speed limits should be reduced in advance of a downhill section to account for the lag time involved before retarders are engaged (if fitted). Consult the vehicle's operator manual to determine braking capability and retarder lag time requirements.

It is common to have different speed limits for uphill or downhill travel. Signs recommending gear selection may be required.

SPEED AROUND A BEND

Speed limits around bends can only remain the same as at the straight sections of road where the super-elevation and radius has been designed to allow this to happen. Where this is not possible, reduce speed limits. Speed limits will need to be sign-posted accordingly.

Lighting

Lighting an extractives site is more difficult than lighting a public road because of the uneven surfaces and the deceptive effects of shadows. Provide adequate lighting to enable workers to move safely around places of work.

In addition to vehicle-mounted lights, lighting should be provided:

- around plant, services and buildings
- on pedestrian routes
- where loading and unloading takes place
- at tip points
- at water bodies where access is required, for example to pontoons and pumps
- where practical, such as at important instructional signs.

A vehicle's lights should be sufficient to enable it to be driven safely. Additional lighting may be required for manoeuvres such as reversing, dumping, or at intersections.

Position lights so they do not dazzle the driver when they come around a corner or drive over a crest. When using diesel- or petrol-powered lighting systems, make sure they:

- are positioned safely (for example, off road lanes)
- will last the shift without needing to be refuelled
- form part of your maintenance schedule.

Maintaining control over roads and other vehicle operating areas

Regardless of whether your operation has a PHMP or not, you should have identified control measures and implemented them to make sure that what has been planned will be carried out.

Put a structured programme of inspections in place to check and verify that your control measures for roads and other traffic areas are maintained. These should be inspected regularly by a competent person, with the reports reviewed by a supervisor or manager.

There may be times when inspection by a competent person, external to your business, is needed.

PART D

Managing safety risks for extractives operations

IN THIS PART

This part of the guide sets out site safety practices for working with explosives, managing ground instability, tipping and dumping material, storing water and tailings, vehicles and traffic management, as well as managing hazards relating to plant and structures.

9.0

Using explosives

IN THIS SECTION:

- 9.1 Requirements for explosives
- 9.2 Hazard management and emergency planning for explosives
- 9.3 Maintaining, transporting and storing explosives
- 9.4 Shotfiring: safe systems of work
- 9.5 Explosives selection criteria
- 9.6 Drilling, charging and blasting
- 9.7 Firing
- 9.8 Post-firing
- 9.9 Misfires
- 9.10 Minimising blast damage

Using explosives to break rock at a mine or quarry is hazardous. You must manage the blasting process to protect workers and the public from a blast.

This section provides guidance on managing the risks of working with explosives, from planning and preparing, to blasting and disposing.

9.1 Requirements for explosives

Safe and efficient blasting requires extractives operators and supervisors to understand and follow the correct procedures.

Risks to health and safety must be eliminated so far as is reasonably practicable. If elimination is not possible, risks must be minimised so far as is reasonably practicable. This includes having practices in place to prevent premature explosions and mishandling of explosives.

Operators must notify WorkSafe about planned blasting activity at least three working days before the first firing using this form [Intended detonation and deflagration of class 1 substances for the extractives industry](#)

The operator must make sure no person uses, handles or issues explosives unless they are a certified handler and hold a controlled substances licence.

The person in charge on the blast/site is the shotfirer. The shotfirer must be a certified handler and hold a controlled substances licence.

Control measures for transport, storage, packaging, manufacture, and disposal of explosives are set under the Hazardous Substances Regulations and the Hazardous Substances (Disposal) Notice 2017. The Hazardous Substances Regulations also specify control measures to make sure heat, shock, pressure, spark energy and electromagnetic radiation and static energy are safely managed.

For more information on hazardous substances, see Section 5.

9.2 Hazard management and emergency planning for explosives

Principal hazard management plan

Any mining operation, A-grade quarrying operation or A-grade alluvial mining operation where explosives are used must have an explosives PHMP and an emergency management PCP. Sites where explosives are used must have an appointed manager qualified under the MOQO Regulations and [Health and Safety at Work \(Mining Operations and Quarrying Operations – Prescribed Competency Requirements for Certificates of Competence\) Safe Work Instrument](#)

Their certificate of competence may have extra or different requirements for using explosives.

A PHMP for explosives must contain the general requirements listed in Section 2.6 of these guidelines and Regulation 68 of the MOQO Regulations. It must also include the specific explosives PHMP requirements set out in Regulation 86 of the MOQO Regulations.

Emergency management PCP

The emergency management PCP must include the information set out in Regulation 105 of the MOQO Regulations. See also Section 3.0 of these guidelines.

Emergency response plans for explosives should be part of the site's emergency management plans or PCP and should align with the Hazardous Substances Regulations.

Control measures for managing explosives at B-grade operations should be in the operation's HSMS.

9.3 Maintaining, transporting and storing explosives

All equipment used for shotfiring should be checked before use and kept in a safe working condition.

Service the equipment regularly, based on how much it is used and the original equipment manufacturer's (OEM) recommendations.

The explosives PHMP must cover how to inspect and report on the safety of equipment used to make, store, transport, and deliver explosives. It must also explain how to make unsafe equipment safe.

Transporting explosives

The PCBU in charge of transporting explosives must meet all the requirements listed in Part 8 and Part 9 of the Hazardous Substances Regulations.

These include, but are not limited to:

- making sure there is a certified handler personally controlling the transportation or the explosives are secured (see Regulation 9.48 of the Hazardous Substances Regulations for more information)
- meeting the vehicles requirements under Regulation 9.48 of the Hazardous Substances Regulations
- making sure there are sufficient fire extinguishers of the right type
- only carrying people who are needed for the job or an emergency – but if carrying more than 250kg of class 1.1, 1.2, 1.3 or 1.5 explosives, there must be at least two people in the vehicle
- making sure that the amount of explosives transported is within safe load limits

- maintaining separation distances and informing drivers of these both verbally and in writing
- making sure vehicles do not stop unless there is an accident, incident, emergency, need for urgent refuelling or another valid reason. If a vehicle does stop, the duration must be minimised. Explosives must be managed using an emergency response plan according to Part 5 of the Hazardous Substances Regulations.

All operations must include transporting explosives in their explosives PHMP. This must include inspecting and reporting on the safety of transport equipment and how to take the right actions to make the equipment safe.

Storage of explosives

Explosives must be stored according to Regulations 9.17 to 9.30 of the Hazardous Substances Regulations. The regulations cover:

- requirements for magazines
- segregation and separation distances
- emergencies.

For more detailed information on storage of explosives see AS 2187.1-1998 Explosives – Storage, transport and use Part 1: Storage [Australian Standard AS 2187.1:1998 Explosives – Storage, Transport and Use – Storage – VIC – Australian Business Licence and Information Service](#)

Tracking explosives

Tracking means recording what happens to hazardous substances during their lifecycle – from manufacture or import, through distribution, to use and disposal. For more information, see Regulations 19.1 to 19.7 of the Hazardous Substances Regulations.

Explosives must be tracked

All operations must explain how explosives brought in and used at the operation will be accounted for in their explosives PHMP. This should include regular stocktakes of magazine locations and checking against transfer logs.

Security of explosives

Explosives must be secured at a hazardous substance location or designated use zone according to Regulations 9.18 to 9.21 of the Hazardous Substances Regulations.

They must be stored in containers that meet the requirements of Regulation 9.19 of the Hazardous Substances Regulations, unless under the personal control of a certified handler.

All operations must include secure storage for explosives in their explosives PHMP, along with a system for signing explosives in and out.

They must also cover the inspection and reporting on the safety of equipment used for storing explosives in their explosives PHMP. Including steps to make the equipment safe.

9.4 Shotfiring: safe systems of work

You must make sure, so far as is reasonably practicable, to have safe systems of work in place that meet your obligations under HSWA, the Hazardous Substances Regulations, and the MOQO Regulations. Control measures for explosives use should include:

- protection against unintended initiation and how to deal with misfires
- hazard identification and checklist for clearing the blast zone before final connection
- a clear and concise procedure detailing the role of sentry guards at a site
- clearance distances and suitable shelter for all workers and people nearby throughout blasting activities
- face checks (before designing the drill plan and/or face profiling), installing suitable edge protection, and delineation of the blast zone from general operational activities
- storage, transport, and security of explosives (including magazine management if required)
- suitable blast warning signals (visible and audible), isolation barriers, and warning signs
- clear understanding of who should be in attendance throughout the blasting process.

Mining operations, A-grade quarrying operations and A-grade alluvial mining operations should address the identification and control of risks related to blast effects (noise, vibration and fumes) in their explosives PHMP. This should include managing risks during the charging and firing of explosives and in particular places (such as storage bin feeders used to clear blockages).

PCBUs with management or control of a hazardous substance location must control adverse effects of unintended initiation according to Regulation 9.27 of the Hazardous Substances Regulations.

PCBUs with management or control of a class 1 substance must meet the requirements of Regulation 9.30 of the Hazardous Substances Regulations.

Individual blast risk assessment

A formal risk assessment should be completed for each blast, to identify the hazards and control measures at each stage, including the extent of the blast exclusion zone during the firing sequence.

Before blasting, any risk assessment and control measures should be agreed to and approved by all the relevant parties involved in the blasting process.

See Table 9 for a list of factors to consider during the risk assessment.

FACTORS TO CONSIDER IN A BLAST RISK ASSESSMENT

Shot considerations	<ul style="list-style-type: none"> - the type of shot (cast, stand-up, river protection rock and so on) - intended outcome of the shot (such as maximum fragmentation or maximum heave).
Geology of the area	<ul style="list-style-type: none"> - the ground type (hardness of bedding planes) - known geological abnormalities in the blast design area (including the face and any potential cavities and/or caves encountered during loading of explosives).
Blast design	<ul style="list-style-type: none"> - burden and spacing (including blast design) - bench height - maximum instantaneous charge (MIC) weights to control environmental impact - vertical location of the bench - the designed blast powder factor - timing and effects - equipment and personnel safety - access to and from the proposed blast exclusion zone - location of equipment and safety of workers during the blast (flyrock) - location of protected works or associated works - location of external infrastructure potentially affected by the blasting activities (buildings, roads, rail, underground services and power) - initiation timing - declared exclusion zone.
Environmental considerations	<ul style="list-style-type: none"> - historical records of fly rock events - understanding of minimum burden to be blasted to reduce risk of flyrock and overpressure - presence of water - historical or current underground workings - the formation and management of any blast fume - radio communication 'black spots' - the expected weather conditions.

TABLE 9: Factors to consider during a blast risk assessment**Blast design**

Blast designs will vary from site to site as different rock types require different explosives to be effective. The blast design should be tailored for each blast, in view of the conditions on the site. To be successful, evaluate the site-specific conditions for:

- the intended slope design and compliance with the mine plan
- geology - especially structure, hardness and other potential geological structures that may cause risk during blasting operations
- water conditions (perched aquifers, groundwater and surface water)
- vibration prediction
- angle of initiation
- blast pattern
- available free faces
- environmental consideration (dependant on the area of the blast technologies including face profiling, bore tracking and the use of electronic initiation systems may be required).

Once these conditions are defined, a controlled blast design can be developed that considers site-based risks.

The design should:

- make sure rock movement is contained in the declared blast exclusion zone, and includes any special precautions required to achieve this (for example, additional or false burden, use of blast mats)
- control ground vibration and air blast
- keep back-break to a minimum through optimised blast planning
- make sure the shape of the muck pile suits the loading equipment at the site
- make sure muck piles are created so that access for face scaling can be carried out
- minimise the risk of misfires
- enable the location of any misfired shots to be determined accurately
- include consideration as to the type of bulk explosive (ammonium nitrate fuel oil or emulsion) and initiating explosive (non-electric or electric detonators).

9.5 Explosives selection criteria

Ground conditions

Modern explosives used in extractives operations are typically safe when handled correctly. However, they can explode if exposed to excessive or prolonged friction, impact, shock or heat.

Potential hazards include:

- running pumps dry or dead heading them, when pumping from a mobile processing unit
- fires near process equipment or storage areas
- contamination from incompatible chemicals.

To manage these risks, assign a person to oversee the situation, typically the Mobile Processing Unit (MPU) operator.

Record all blastholes containing water to reduce the risk of misfires. For wet blastholes, use water-resistant explosives. For damp blastholes that need to sleep, use explosives with some water-resistant properties. Explosives containing high levels of emulsion are preferred to manage wet or damp holes because of their high-water resistance.

Use a clear system to identify and manage wet blastholes. For example, spray painting the depth of water next to the blasthole. You could also undertake dipping of the blastholes before charging. This helps operators or shotfirers identify holes needing dewatering or emulsion-based explosives.

Blasting in oxidising or reactive ground

Sulphide minerals and coal may oxidise rapidly when broken and exposed to air. If they are present in your operation, test to see if the ground is reactive.

The explosives to use and charging practices to adopt should be developed in consultation with explosive manufacturers and follow these precautions:

- Sheath ANFO explosives to inhibit exothermic reaction between the explosives and the blast material.
- Wash down all exposed surfaces in the blast vicinity to make sure there is no fuel available for a secondary explosion.
- Use the correct amount and type of stemming in all blastholes to prevent flame fronts developing at the blasthole collar.
- Use low explosive strength detonating cord that is not in contact with rocks or dust (to avoid detonating cord raising and igniting dust).
- Select the correct stemming for the conditions – usually a clay-rock stemming is preferred.

9.6 Drilling, charging and blasting

Drilling blastholes

Risks associated with the drilling of blastholes include residual explosives from previous blasts being encountered and initiated, and inaccurate drilled blastholes creating an unsafe situation during firing. Inaccurate drilling may be caused by the geology of the ground or operator skill levels.

Blast geometry and design is critical to create safe discharges and blast results.

Blasthole diameter, inclination and length should be adequately designed and recorded for the selected drill pattern. Correct drilling of blast designs will make sure hazards such as over break, fly rock, or air blast overpressure are significantly reduced.

A driller's log should be provided to the driller, and the operator should note any potential inconsistencies in the drill hole including interception of water (and at what depth), and the location of any cavities or caves.

The following standards and procedures should be in place:

- The drilling site should be prepared and drill holes marked before drilling.
- Drilling should not be carried out on any face or bench until it is examined for misfires and suitably treated. For more information see Section 9.9.
- The driller should record every drill hole including date, time, length, inclination, and position relative to a fixed point or benchmark.
- The driller should record any unusual events during the drilling (for example cavities, soft rock, or an inability to drill designated holes).
- When positioning the drill rig or while drilling near the edge of the bench, the drill rig should be positioned so the operator always has a clear view of the edge and far enough away to prevent the drill rig toppling over the edge. Consider using delineators or cones to mark the end of the bench. Provide edge protection for workers working near the edge of the face.
- Do not drill in a hole if any part is too close to a hole with explosives (this distance should be set by a risk assessment with expert technical advice).
- If face profiling and boring tracking holes for accuracy, provide the driller with results to assist them with ongoing accuracy of drilling.
- When drilling near the bench edge, the drill rig's driver access side should face away from the edge.

Charging operations

CLEANING AND MEASURING BLASTHOLES

Check blastholes before loading to make sure they are clear and drilled to the correct depth.

Any blocked blastholes should be cleared, and short blastholes redrilled where possible. To prevent blocked blastholes, protect the hole's collar (for example, using caps or cones).

Short blastholes can cause increased toe being left, creating digging issues.

Overcharging can increase risk, for example, flyrock, air blast, and increased vibration.

DISTRIBUTION OF INITIATION EXPLOSIVES

Initiation explosives should be placed near the blasthole collar, so they are not in the way of the loading and stemming process.

It is also important that boosters or detonators cannot be accidentally knocked into blastholes or lost in drill cuttings.

If these situations are likely, secure the initiation explosives near the blasthole collar.

PLACING INITIATION EXPLOSIVES IN BLASTHOLES

Use compatible boosters and downhole detonators to form the primer according to the manufacturer's recommendations.

Once assembled, locate the primer down the blasthole without excessive force and take care to avoid unnecessary material build-up between the primer and explosives column.

Take the following precautions:

- Check explosives for damage.
- Report any damaged explosive to the certified handler to dispose of appropriately.
- Secure lines to avoid primer being drawn into the hole (slumping).
- Place the tails of the downline neatly at the collar of the blasthole so they are secure and away from any vehicle movements. Tie them to a rock or stick to keep things tidy and reduce the risk of operators tripping over the downhole leads.
- If a downline or primer is lost down the blasthole, notify the shotfirer, record the loss and reprime the blasthole.
- Never use excessive force to remove a jammed primer. If the original primer cannot be removed, use extra priming.

LOADING EXPLOSIVES

When loading explosives, avoid damaging down lines or pulling the down line into the hole. Take the following precautions:

- Load the shot so the holes furthest from the access point are loaded first.
- Charge the shot in a way that prevents damage to the down line and excessive spillage around the hole.
- Regularly sample the product for quality and density to avoid possible desensitisation by compression (dead pressing).
- When the truck empties during charging of a particular hole, identify any partially filled holes and make sure they are fully loaded before firing.
- Liaise with the contractor about which holes to load and in what order.

MOBILE PROCESSING UNITS (MPUs)

Take the following precautions while using MPUs:

- Do a pre-start check to make sure the vehicle is in sound condition and repair.
- Make sure all workers operating the MPU are competent.
- Make sure MPUs are electrically earthed during mixing and transfer operations to dissipate static charges. This may include electrical continuity through the piping system on the vehicle and fitting tyres that can conduct static charges.
- The operator should have full view of explosive delivery points or be in reliable communication with another operator who has a full view.
- Make sure vehicle access to the shot is near a clearly defined access route designated by the shotfirer.
- In areas of restricted visibility, use a spotter to control vehicle movements.
- When working near the edge of the bench, identify hazards and appropriate fall protection.
- Before accessing public roads, wash explosive residue should be washed with water from pump hoses, explosive mixing receptacles, and so on.

PNEUMATIC CHARGING

Pneumatic charging devices should be properly earthed. Operators should wear antistatic footwear, remove their gloves, and earth themselves before touching electric detonators.

PREVENTION OF FLY ROCK

Preventing fly rock is important. The main causes of fly rock are:

- The explosives column is brought too high up the blasthole. Check that the stemming height matches the blast design.
- The rise of explosives has not been checked. Bulk explosive has filled into a cavity, fissure, joint voids or cracks, all of which may reduce the burden and cause over charging.
- Blastholes have deviated when drilled and are closer together, causing a portion of the shot being over charged.
- The drill angle on an inclined blasthole reduces the burden at the bottom of the hole causing overcharging.
- A section of rock has fallen out of the face after profiling, causing an unidentified reduced burden and overcharging.
- Poor delay sequences cause too much time between adjacent holes reducing burdens during blasting and leading to fly rock.
- The amount of explosives placed in the blasthole is not suitable for the rock type leading to overcharging.
- A geological anomaly creates a band of weaker rock in front of a charged blasthole, which can cause overcharging. These anomalies are hard to spot because the surface rock looks the same as expected. The drilling could be into competent rock with a band of weaker rock located between the blasthole and the free face.
- Rock around the collar may be fragmented by blasting the previous working bench.

Understanding the geology is key when developing blast design. Before charging the blastholes, it is important to double-check this information. Following the blast design carefully helps make sure the blast goes smoothly and safely. If conditions change, you may need to adjust how the explosives are distributed.

PCBUs must make sure no one is exposed to any hazardous fragment by limiting the quantity of explosives used.

Shotfirers should:

- frequently check the rise of explosives in the blasthole
- visually check the alignment (azimuth) and inclination of every blasthole and compare them with the design
- carefully consider any deviations
- consider re-profiling if a rock falls or a slip has occurred after the initial profile was done
- include a written delay sequence schedule in the blast specification so excessive delay periods can be easily identified
- check the powder factor for the rock type to calculate the quantity of explosives (compare with previous successful blasts if needed)
- examine other site faces for evidence of joint voids or cracks

- consult with the driller and check the drillers log for evidence of geological anomalies (for example, voids, clay seams, cavities, fissures, joint voids, cracks or weaker rock)
- consider increasing the top stemming where rock around the collar is fragmented by blasting the previous working bench.

SLEEP TIME IN BLASTHOLES

Sleep time of an explosive matters because explosives can deteriorate when exposed to heat, cold, humidity, and water and could cause failure of the explosives. Product deterioration may result in a charge, or part of a charge, failing to explode or misfiring. Explosives should be charged and fired as soon as possible.

When a blast is being slept, complete a full risk assessment, including site management and blasting personnel. If the risk assessment shows blast guards are needed, they should be assigned, briefed, and stay in position until the blast is fired.

CHARGING DURING SHIFT CHANGES

When charging is being done during shift changes, make sure a written procedure is in place for communication between the shifts. Share information about charging and blasted locations, holes loaded, and any unique hazards or unusual circumstances associated with the shot.

PPE

You must identify hazards that may arise when charging and firing explosive, and you should provide and wear personal protective equipment (PPE). Safety Data Sheets for the products being used will outline PPE requirements. These may include gloves, goggles, and sometimes, anti-static clothing.

ACTIVITIES IN PROXIMITY

Avoid any activity being done near the shot that could generate heat, sparks, or an impact or pressure shock that could cause an explosion or fire. This includes smoking, naked flames or operation of machinery. Unauthorised workers and machinery not involved in the blasting operation should be removed a safe distance from the area.

VEHICLES ON NON-ELECTRIC BLAST

If vehicles are used at non-electric blasts, there is a risk of a premature explosion or misfire if they run over detonators or damage the signal tube. Use a clearly defined access route for vehicle access to the shot. Where there is restricted visibility, use a spotter to control vehicle movements.

SIGNAGE

Charging areas should be clearly marked by appropriate warning signs and comply with Regulations 2.5 to 2.10 of the Hazardous Substances Regulations.

Where charged blastholes will be left to sleep overnight, suitable barricades, warning signs and lighting should be used. Approaching vehicles and people need to be able to clearly identify the charge area. If further warning is required, an overnight guard can be used to direct people and vehicles around the shot area.

COMMUNICATION DEVICES

When using electric initiation, the blasting circuit can be energised by the electric field produced by radio transmitters, mobile telephones, two-way radios, vape pens, and so on.

Such devices should never be carried while holding or connecting electric explosives.

Safe distances for electronic detonators subject to radio frequency should be determined.

Stemming

Avoid damaging the down line connected to the primer when placing stemming material. Take the following precautions:

- Make sure the hole is loaded with explosives, and the collar length is correct.
- Check the tension on the down lines to make sure the primers are in the product.
- Check the stemming material is a suitable quality and does not contain large fragments of rock that may cause damage to down lines.
- Approach the hole from the side opposite to the marker securing the initiating line if loading with mobile plant.
- Leave blastholes charged with gassed bulk explosives un-stemmed for the recommended time to allow for expanded gas bubbles. The shotfirer will check holes for gassing of product, then advise workers when and where to start stemming.
- Stem all loaded blastholes before the end of the shift. If this is not possible, consider blocking the blasthole with a gasbag or covering it with drill cuttings.

TAMPING RODS

Use only wooden or other non-metallic rods when tamping to prevent an explosion from shock, friction, or impact. Make sure the lead wires, detonating cord, or signal tube connected to the primer are not damaged during the tamping process. A primer should never be tamped because impact could cause it to explode.

STEMMING HOPPERS

If mobile plant is used to carry a hopper to load stemming into charged blastholes, the mobile plant should have good visibility (use a spotter). Take care not to damage down lines on charged blastholes. Complete stemming as soon as possible.

Initiation

Consider the following when connecting shots using non-electric, detonating cord, or electric initiated systems:

- Workers carrying out the hook-up should be trained, competent, and follow a tie up plan.
- After connecting the shot, check to confirm it is correct. The shotfirer in charge of the blast is ultimately responsible for the hook-up and should personally check the connections before firing.
- You must make sure that the system for firing the explosive is not readied to the point that only one final action needs to be taken to fire the charge, until all safety requirements have been done, including clearing the blast area.
- If a thunderstorm develops, the person in charge should assess its proximity and decide whether to continue activities. If it approaches, stop handling or preparing the explosives and evacuate everyone in line with Regulation 9.29(3) the Hazardous Substances Regulations.
- Where a shot is not going to be fired, the shotfirer should disconnect the control row before evacuating, if safe to do so.

NON-ELECTRIC FIRING

A procedure should be in place to provide a safe hook-up of non-electric explosives. Connections and detonating cord charge weight (grams of explosives per metre) should follow the manufacturer's instructions.

ELECTRIC FIRING

Below are some things to consider when doing any electric firing:

- Electric detonators are susceptible to accidental initiation by sources of stray electricity. To reduce the risk of accidental ignition, keep wire ends, connectors and fittings shorted (twisted) until immediately prior to use.
- Do not use electric detonators near power lines or other potential sources of electric current.
- Stop all surface charging operations if an electrical storm is imminent. Use lightning detector devices to track storms and lightning strikes, to see if surface charging operations should be stopped. Select an appropriate detector for the type of charging operation and follow the manufacturer's instructions.
- Keep detonators clear of the ground until charging starts.
- Never hold an electronic delay detonator while it is being tested or programmed.
- Do not use plastic liners in blastholes unless they are permanently conductive.

Where any explosive is to be fired using an electrical system other than those firing systems initiated only by electrical currents modulated to specific waveforms or pulse sequences, the area within 2m of the uninsulated portion of the electrical firing system must not be subject to stray electrical currents of more than 60mA.

When doing any electric firing near radio masts or antennae, cell towers, communications towers or satellite dishes, consider Regulation 9.16 of the Hazardous Substances Regulations requirements before designing the blast. Alternatively use non-electronic blasting methods.

CIRCUIT TESTERS

Before connecting the firing circuit, check the detonating circuit and firing circuit for continuity. It is possible an explosion might occur when testing. Therefore, put appropriate control measures in place, including clearing the blasting area and choosing a safe location for testing. The shotfirer should make sure the circuit tester is maintained in correct working order.

SHOTFIRING CABLE

When using a shotfiring cable to initiate a blast, the shotfirer should make sure the cable is properly protected and insulated for the blasting conditions. Take precautions to prevent the cable contacting electrical installations, metal objects, or anything that could damage the insulating cover.

Keep the cable short-circuited at each end during the charging operation and at the power end while the leads from the detonators are being connected. The short-circuit at the power end should not be opened for connection to the source power until the blasting area is clear of people. As soon as the blast has been fired the short-circuit should be re-established by physical disconnection from the exploder.

EXPLODERS

Only exploders capable of storing or generating the electrical energy required to reliably initiate electric detonators should be used. They should be carefully handled and regularly tested to ensure reliable performance.

Explosives must not be exposed to:

- impact or pressure shock that could cause an unintended explosion or fire
- any ignition source that could create a spark and cause an unintended explosion or fire
- any ignition source that generates heat or fire that could cause an unintended explosion or fire
- the build-up of static electrical charges that could lead to an unintended explosion or fire.

9.7 Firing

Blast exclusion zone

The shotfirer, certified handler, and site operator should set the blast exclusion zone and the location of guards by doing a risk assessment that considers any technical concerns or known hazards in the shot.

The PCBU with management or control of a hazardous substance location must comply with Regulations 9.27 and 9.30 of the Hazardous Substances Regulations.

Warning procedures

The PCBU in charge of the detonation must make sure anyone not specifically authorised by the certified handler to be in the designated area is kept out, using these methods:

- Information must be displayed that:
 - warns a substance is being detonated, and entry is prohibited
 - is visible from all points 5m outside the perimeter of the designated use zone
 - should meet the level of comprehensibility and clarity required for signage in Part 2 of Regulations 2.5 to 2.10 of the Hazardous Substances Regulation.
- Make a visual check of the zone immediately before firing to confirm all people not directly involved are excluded.
- One minute before firing, sound a distinctive warning that is loud enough to be heard throughout the zone and 5m beyond, by someone with normal hearing.

External parties

If necessary, give external parties warning before conducting blasts. External parties may include adjoining properties, residences or the general public.

Withdrawal of people and machinery

Before firing the shot, people in the vicinity of the blast area must be warned and moved to a safe area outside the blast exclusion zone. They should not return until the 'all clear' signal is given. It is critical that everyone involved in the blast can reach a predetermined safe position before firing.

Machinery in the blast exclusion zone should be moved, where possible, to a safe location to make sure machines are not damaged by flyrock.

Do a visual check of the blast exclusion zone before firing.

Signage

Information must be displayed to warn people there will be a blast and entry is prohibited. Signs must be clearly visible and written so people can clearly understand them.

Audible warning device

An audible warning device must be used to indicate a blast is going to take place. The device must make a sound that stands out from any other warning or operational signals on site. It must be loud enough to hear throughout the blast zone and at least 5m beyond.

Radio signal

If radios are used for warning signals, everyone on site should clearly understand what they mean.

If the site uses more than one radio channel, choose one channel to always use for blasting. The warning signal should also be broadcast on all other channels used in the blast area.

Preventing access to the blast exclusion zone

Place adequate roadblocks and guards at any road or access point into the blast exclusion zone during the firing, and keep them there until the shotfirer gives the all clear.

Blast monitoring

When blasting near buildings or structures, monitor ground vibration and air-blast overpressure to record the blast details.

The shotfirer must make sure the firing is monitored.

9.8 Post-firing

Post-firing inspection

The certified handler should inspect the area after the blast. Before entering the blast area, wait long enough for dust and fumes to clear. Going in too soon can cause illness from breathing in toxic gases and fumes. Dust and fumes can also make it hard to see, causing accidents like collisions, falls, trips or missing unstable rocks.

Where a blast is initiated by electric detonators, disconnect the firing cable from the exploder immediately after firing, and before the post-firing inspection. Short-circuit the ends of the firing cable together, and remove the key from the exploder.

The purpose of a post-firing inspection is to confirm conditions in the blast area are safe to restart the work. In particular, the shotfirer should look for evidence of unstable ground, misfires, and burning explosives.

UNSTABLE GROUND

Blasting can cause vibrations, concussion and ground stress changes that may loosen rock around walls - even those far from the blast site. Blasts can also create voids under the blast area, especially in places with underground workings, limestone, or soft ground. Areas stable before a blast might become unsafe or even collapse after blasting, particularly with large blasts. Falls of ground are a serious safety risk for workers nearby.

When inspecting after a blast, approach the area carefully and avoid the toe and crest of the face. If possible, inspect the blast muck-pile from a bench below or to the side.

MISFIRES OR BURNING EXPLOSIVES

If explosives misfire or burn, there is a serious risk of additional detonations, which can cause blast damage and flying rock. Misfired explosives can be hard to spot, and accidental detonation in a confined space can lead to fatal or serious injuries.

During the post-blast inspection and all mucking operations, carefully check for any signs of misfired detonators or detonating cords. If a misfire is found, you must make sure no person approaches the misfired charge for:

- 10 minutes for electrically fired charges
- 60 minutes for charges fired by a fuse.

Do not give the all clear and keep all guards, barricades and signs in place. The certified handler should notify the quarry or mine manager right away.

Only after the post-firing inspection is complete and the area confirmed as safe, should the all clear be given and barricades, cautionary signs and guards removed.

For more information on misfires, see Section 9.9.

The certified handler must make sure any misfired charge is identified (see Part 2 of Regulation 9.29(2) of the Hazardous Substances Regulations).

Prevention and management of post-firing fumes

Blasting can release toxic gases like nitrogen oxides, ammonia, nitric acid, carbon monoxide, and carbon dioxide into the air in large amounts. These gases are known as blast fumes, and even low levels can be a serious health risk. Nitrogen dioxide is visible as a reddish-brown colour; the others are not visible.

Safety management systems should include the different control phases for blast fumes such as:

- prevention: how to prevent or minimise blast fumes
- management of fumes: where blast fumes extend beyond the blast exclusion zone
- management of an exposure: for when people are exposed to blast fumes.

Mining and quarrying operations should include control measures in their explosives PHMP and emergency management PCP.

PREVENTION

Wet ground is closely linked to the production of excessive blast fumes.

Other factors that can cause blast fumes include:

- incorrect fuel to oxygen ratio
- product pre-compression
- insufficient priming
- acidic soils
- presence of pyrite
- product formulation.

Blast fumes can be reduced by:

- selecting the right explosive for the conditions
- dewatering holes before loading
- keeping sleep times to the minimum time recommended by the manufacturer.

Understanding and applying meteorology (such as weather conditions, wind speed, direction and stability classes) and gas cloud distributions help calculate how long a blast gas plume will take to reach areas of interest. For example, a 'smoko' hut, workshop, office or house. Buildings should not be used as shelters unless assessed by competent persons as safe havens. This knowledge also helps determine how far the gas plume will spread and how the gas concentration will change with distance.

Anyone developing prevention and emergency management plans should understand the gas toxicology and the exposure standards of a gas, such as nitrogen dioxide, especially for high concentrations over short periods.

MANAGEMENT OF FUMES

Before a gas plume occurs, it is important to have a system for managing a potential incident including evacuations. The system should include information about wind speed, wind direction and the location of the safe assembly point. Communication systems should be in place and already tested.

MANAGEMENT OF AN EXPOSURE

Exposure to nitrogen dioxide can cause delayed health effects that may be life-threatening, even if the person initially seems unaffected. For this reason, anyone exposed to nitrogen dioxide should get medical help immediately and stay under observation as advised by their doctor. As a precaution, they may need to be monitored for up to 12 hours.

Safety data sheets for all products being used should be readily available to everyone involved in the blasting process.

9.9 Misfires

Important

All misfires must be notified to WorkSafe as soon as discovered.
For more information on notifications see our webpage [Notify WorkSafe](#)

Shotfiring notifiable events include:

- any incident in which any part of an explosive charge, after initiation, fails to completely detonate (misfires)
- any unplanned or premature ignition of a shot
- any accident where a person suffers injury or dies as a result of shotfiring
- any accident where material is projected beyond the declared danger zone, or otherwise exposes any person to danger during blasting operations.

Your site should have a written procedure providing a safe system of entry and inspection for misfires and their treatment, including the methods used to detect a misfire.

Mining operations, A-grade quarrying operations and A-grade alluvial mining operations must have procedures in their explosives PHMP to find, recover, and detonate misfired explosives. Keep records for all misfired explosives.

The PCBU who directs the carrying out of the detonation or deflagration of an explosive must make sure any misfired charge is identified.

Determination of misfires

Methods used to determine if a misfire has happened are based on many factors, including appropriate training, standard operating procedures, and guidance from standards (for example *AS 2187.2-2006 Explosives – Storage and Use*).

There are certain events that indicate a misfire has happened, including:

- when any part of an explosive charge fails to completely detonate after initiation
- if using safety fuse, the number of shots counted is less than the number of holes fired or a disagreement on the count of shots fired
- if damaged safety fuse, detonating cord, lead wires or unfired signal tube is exposed in a hole that has been fired
- evidence of cut-offs, butts, or remaining portions of blastholes (for example boulders with drill holes) suspected of containing explosives
- holes that have slumped between charging and firing, due to dispersion of the explosive from water ingress or through joints and fissures
- if during the normal excavation of the blasted ground, uninitiated explosives are found or the load out mobile plant encounters poor 'diggability' of the blasted ground
- uninitiated product found in the processing of material.

A careful examination of the debris for explosives should be done and, if present disposed of safely (see 'disposal of surplus and defective explosives and packaging' later in this section for more information).

Misfire treatment

If you find a misfire, do not attempt to drill into the charged blasthole. Instead, do a hazard identification and risk assessment to decide on a safe way to handle it.

Be aware that a misfire among multiple charges can cause excessive rock scatter when fired, because the successful shots have relieved the overburden. In such cases, make sure adequate extra cover is used.

REMOVAL OF STEMMING AND RE-PRIMING

Where a blasthole has completely misfired, the stemming may be removed by either applying water under pressure or by compressed air and water through a length of antistatic hose (such as FRAS). No metal fitting should be in the hole.

If water under pressure (or water and air pressure) is not available, the stemming may be 'sludged' out using water and a wooden or other approved implement. Do not use just compressed air.

When the stemming has been removed a fresh priming cartridge may be inserted and the blasthole again stemmed and fired. An artificial burden or cover should be placed around and over the hole to prevent fly rock.

If a misfired blasthole contains ANFO (an explosive material consisting of ammonium nitrate and fuel oil) or emulsion-based product, it may be 'sludged' out down to the primer using the same procedure to remove stemming. The slurry explosive washed out should be treated as deteriorated explosives and dealt with as detailed in Section 11.2. The blasthole should then be re-primed and fired to explode the original primer. Do not remove a primed charge from the blasthole.

RELIEVING BLASTHOLE MISFIRE TREATMENT

If it is not possible to explode a misfire by re-firing, a relieving blasthole should be drilled parallel to the original blasthole then charged and exploded as follows:

- Mark the misfired blasthole clearly or block it by inserting a wooden plug.
- If the misfired blasthole is 50mm or less in diameter and less than 3m in length, do not drill the relieving blasthole closer than 600mm to the nearest point of the misfired hole.
- If the misfired blasthole is larger or longer than 50mm and 3m respectively, increase the distance between the misfired blasthole and the relieving blasthole so the misfired charge is not drilled into.
- If an electric detonator is involved, first short-circuit the detonator wires, then tie to a permanent object to recover the detonator after a relieving blasthole has been fired.

All explosives recovered from misfired blastholes should be collected and disposed of as detailed in the section under 'disposal of surplus and defective explosives and packaging'.

SHATTERED GROUND

If the ground around the misfire is shattered, do not use the relieving blasthole method. In this case the ground around the misfire should be carefully cleared until the explosives are uncovered. Do this cautiously by following the wires or fuses down to the charge, and removing the last few inches of cover by hand.

PRE-DRILLING PRECAUTIONS

No blasthole should be drilled in any face or bench until it is thoroughly cleaned and washed down within a radius of 1m from the intended hole. Examine any cut-offs or sub-drill blastholes to make sure they do not contain explosives, then plug sub-drill blastholes with a wooden plug. If examination reveals explosives, the cut-offs or sub-drill blastholes should be primed and fired and the pre-drilling precautions above taken again.

Misfire workers

If a misfired charge is identified, the certified handler must make sure no-one approaches for 10 minutes for an electrically fired charge. For a charge fired by a fuse increase the time to 60 minutes.

The certified handler must then safely dispose of the malfunctioning charge according to the Hazardous Substances (Disposal) Notice 2017.

The certified handler may have an experienced person to assist. All other people must be kept well clear of the area.

The PCBU must make sure the requirements of Regulation 9.28(3) of the Hazardous Substances Regulations are maintained until safe disposal by the certified handler is completed. This includes displaying information, sounding warnings and visual checks.

LOADING OUT A MISFIRE

Before retrieving misfired material, a written hazard identification and risk assessment should be completed by competent people. This assessment should consider the site shotfiring procedures and focus on key areas like:

- the excavator may need to have extra protection for the operator. This depends on the properties of the material involved
- using CCTV or other suitable means of isolation to observe the muck pile during the loading operation, so the mobile plant operator can be alerted to the presence of suspect material

- how blastholes involved in the misfire can be located in the muck pile. Survey equipment may be used which can define the hazardous area more accurately
- flags, bunting, or warning notices may be needed to mark the areas identified.

While the mobile plant operator recovers explosive material, accidental initiation can occur by:

- the mobile plant's bucket striking the explosive material during excavating, and rock falling and striking the explosive material
- mobile plant running over the explosive material
- movement of rock in the bucket when transporting
- tipping the rock out of the bucket at the search site.

All explosive materials are sensitive, some more than others. Heat, pressure and friction can initiate the explosives or detonators, especially if they are damaged.

When misfired charges are found, the PCBU who directs detonation or deflagration of the explosive must safely dispose of them.

Records

Blasting records including all key parameters such as hole specification, burden and spacing, quantities of explosive used, tie-in pattern and number of delays should be documented and records kept.

Reporting requirements

The certified handler should report all misfires to the PCBU.

Misfires and other explosive incidents must be reported to WorkSafe in accordance with Schedule 5 of the MOQO Regulations.

Disposal of surplus and defective explosives and packaging

The disposal of explosives is considered an inherently hazardous task. There have been a number of fatalities and serious injuries where people have attempted to dispose of explosives themselves. Disposal of explosives should only be done by fully trained, competent people with specialist experience in this field.

EXPLOSIVES NO LONGER REQUIRED

Explosives that are no longer needed should be returned to the supplier. If they cannot be returned disposal must be done according to the Hazardous Substances (Disposal) Notice 2017. Do not throw away, bury or flush explosives.

EXPLOSIVES FOUND WHILE LOADING

Treat any suspected explosives found while excavating as live. Shut the area down, set up a prohibited zone and put control systems in place - including informing the site manager.

DETERIORATED AND DEFECTIVE EXPLOSIVES

The Government provides a free collection service for the disposal of deteriorated and defective explosives which is conducted by Civilian Ammunition Inspectors and the New Zealand Defence Force.

To arrange for the collection and disposal of deteriorated or defective explosives contact your local Police station in the first instance (do not dial 111).

Deteriorated and defective explosives include:

- explosives with an expired shelf life
- explosives recovered through a misfire procedure
- damaged explosives.

Explosives packaging

Before disposal, check empty explosive packaging to make sure no explosive remains hidden or lodged in any packaging.

Clearly mark labels so there is no uncertainty of the packaging contents.

Disposal of empty explosive cases

Disposal of empty explosives cases hazardous to the environment must comply with Regulation 10 of the Hazardous Substances (Disposal) Notice 2017.

If burning empty cases after a blast, take them away from the blast site to a secure place. Check no explosive remains hidden or lodged in the case and remove any residual content, then burn them under controlled conditions.

Clear and secure the site during burning. Check the area after burning to make sure there is nothing left of the cases.

9.10 Minimising blast damage

Inappropriate blasting practices can result in substantial damage to the rock mass in the interim and final slopes. The consequences of poor blasting practices include:

- loose rock on slope faces and batter crests
- over-break in the face causing over-steepening of the slope, leading to further instability depending on the level of stability allowed in the original design
- sub-grade damage that can destroy safety benches, leading to reduced effectiveness of retaining loose rock falling from above
- a cumulative reduction in the strength of rock mass where the slope is developed. In particular, reduced shear strength of the structural defects.

Set up standardised drilling and blasting practices, using proven and recognised blast design procedures that suit the ground conditions at the site.

10.0

Controlling ground instability in excavations

IN THIS SECTION:

- 10.1 Planning and design
- 10.2 Excavation rules
- 10.3 Excavation control and scaling
- 10.4 Slope movement monitoring programmes
- 10.5 Working near slopes
- 10.6 Remedial measures
- 10.7 Preventing falls from highwalls or faces
- 10.8 Historic underground workings

To manage the risk of ground instability during excavation, put suitable procedures in place for excavation and monitoring of slopes.

This section describes how to:

- scale and control excavations to prevent rockfall or slope instability
- monitor slopes to detect any instability
- prevent or put right ground instability
- excavate safely under water.

10.1 Planning and design

Before any excavation begins, the responsible person should carry out an appraisal to identify principal hazards. If ground or strata instability is already identified as a principal hazard, a geotechnical assessment of the site ground conditions should be undertaken by a competent person to determine all factors likely to affect the stability of the ground and the limitations that should be imposed on the excavation site design.

This should be documented. The assessment should be reviewed and revised where necessary when a material change has occurred in the ground conditions or the excavation methods.

Effective ground control relies on geotechnical information obtained at different stages of the life of the site – during planning and design, at implementation of the design and through day-to-day operations such as surveying, installation, maintenance and inspections.

Following appraisal of ground conditions, a design should be prepared setting out the measures to control ground instability. Where an existing design has already been proved, it may be used as the basis for the design of a new excavation, if the ground conditions at both sites are not significantly different.

During planning and design, there is usually a relative lack of data available when the slope design is first developed. It is essential that geotechnical information obtained during operations is consolidated with information in the geotechnical model and continually used to assess the suitability of the slope design in relation to ground stability.

Implementing the design typically involves considering suitable ground control strategies, such as minimising unnecessary damage to slopes during blasting, excavation control and scaling, and installation of ground support and reinforcement.

For more information on excavation design, see Section 6.

10.2 Excavation rules

Excavation procedures should be reviewed and revised regularly. The control measures specified in these procedures are essential for the proper management of excavations, ensuring the people working in and around them are safe.

Consider the following in your procedures:

- the way excavation activities should be carried out, specifying the type and reach of excavators
- the physical dimensions of the excavation including slope, height of faces, width of benches, position of catch-berms and gradient, position and protection of access ramps
- the way in which material should be removed from the excavation
- the sequence in which material should be removed
- maintenance of faces (including scaling of crest lines)
- the nature and frequency of supervision
- the response to defects.

10.3 Excavation control and scaling

Good excavation control, scaling, and equipment selection help create and maintain safe slopes.

In soils and weak and weathered rock, batters can be excavated by free digging using hydraulic excavators. It is critical slopes are not under-cut so the as-built slope is steeper than the as-designed slope, as it could result in instability. Provide adequate surface runoff control measures to the benches separating the batters to minimise water infiltration and slope erosion.

In strong rocks, drilling and blasting is needed to fragment the rock mass before the final preparation of the slope. Care should be taken to prevent over-digging of the face, particularly where there is blast damage or fractured rock.

Scaling of the batter crest and face following excavation is an important component of the implementation of the design. Scaling is intended to remove loose blocks and slabs that may form rock falls or small failures. Scaling also helps preserve the catch capacity of benches needed to retain loose rock material rilling from above. In soils and weak and weathered rock, experienced mobile plant operators can construct slopes with smooth surfaces, so scaling is not generally required.

Scaling from the bench above is normally done by chaining the face using a large chain (ship's anchor chain) with or without attached dozer track plates. The chain can be dragged along the face by a dozer or backhoe. Do not use a backhoe to scale the face from the bench above, as large rocks may pull the plant off balance.

Scaling from the bench below is generally performed by an excavator configured as a backhoe. Most manufacturers offer specialised units equipped with long booms holding small buckets or rock picks.

The debris accumulated at the toe of the batter after scaling should be removed before access to the toe is lost. This will make sure adequate catchment volume on the safety bench is maintained. Supplementary bench cleaning will depend on access and the service life of a slope. Periodic bench inspections should identify sections that require cleaning.

Mobile plant working on faces

Faces that have potential for instability should be worked within the reach height of the equipment used, whether they are working in sand or hard rock (see Figure 40). Typically, wheel loaders can reach 6-8m and excavators 9-12m. Larger mining shovels (120t or more) are capable of reaching 18-20m depending on how they are used.

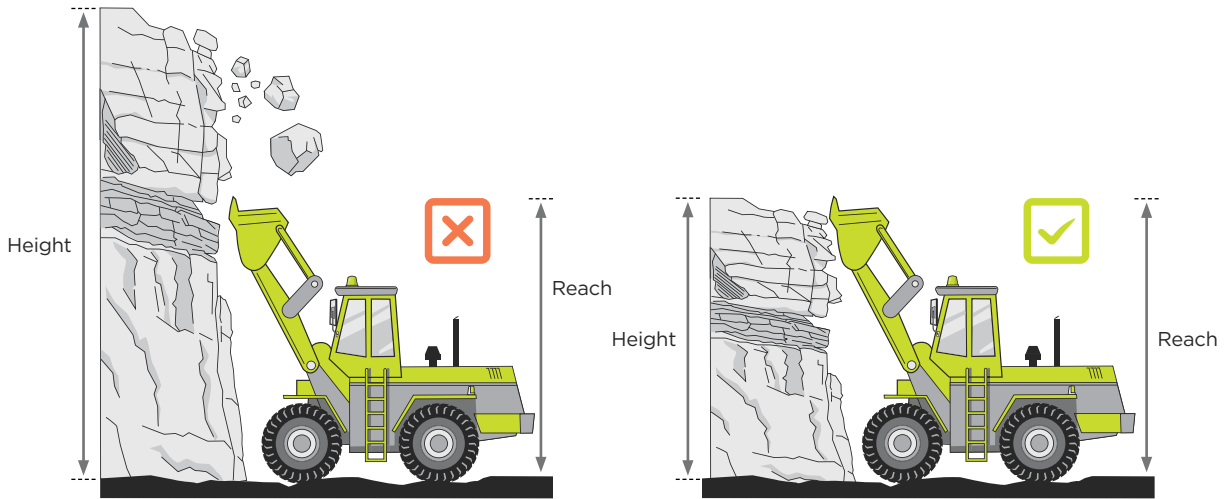

FIGURE 40: Face height should not exceed the reach of the loader used on the face

If mobile plant is at risk of being engulfed in a face collapse, a trench or rock trap should be used to maintain a safe operating distance (see Figure 41).

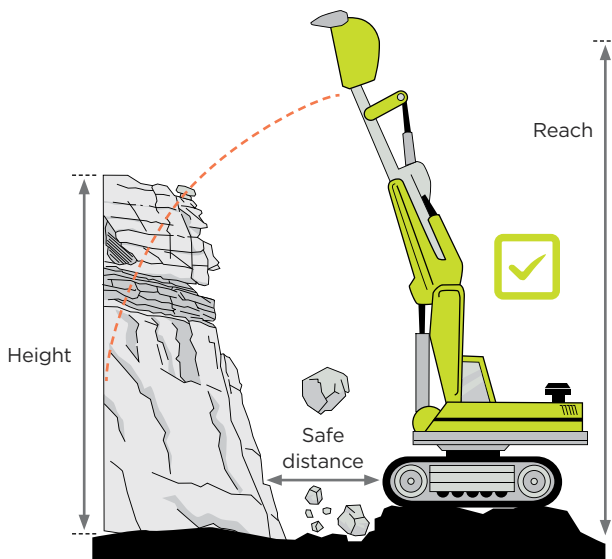
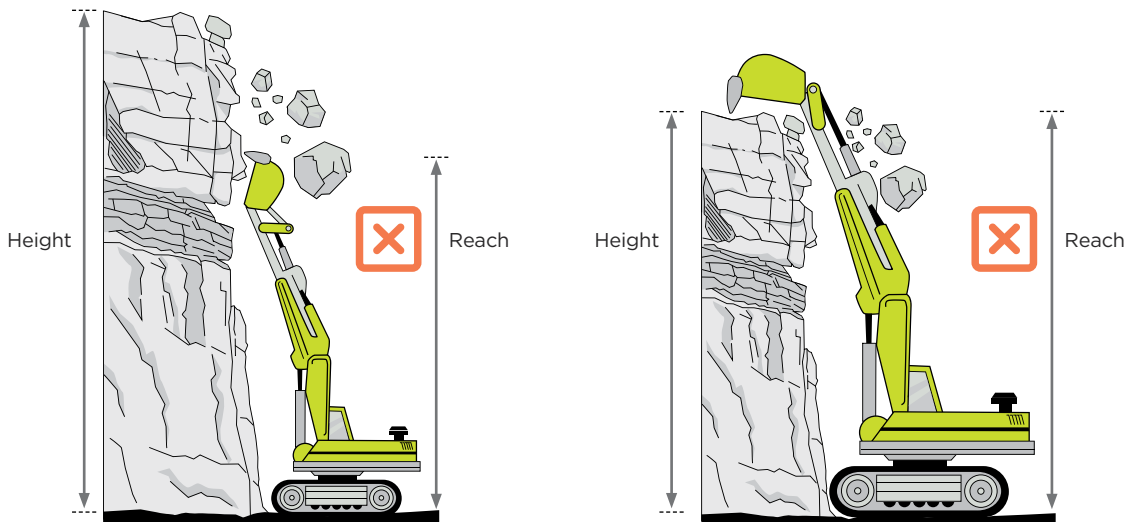

FIGURE 41: Face height should not exceed the reach of the excavator used on the face, with safe operating distances



Post excavation inspection of blasted sections

When the excavator reaches the batter face following a blast, the designed toe and crest should be achieved, and no blast-induced damage should be visible of the face. After excavation is completed, the face should be inspected and analysed for excessive over break. The damage should be classified into the categories shown in Table 10 to help guide design refinement.

CATEGORY OF DAMAGE	WHAT DOES THIS LOOK LIKE?
No visible damage	Joints tight, teeth marks in face, no loose material present, half-barrels visible when pre-splitting and a well-defined toe and crest.
Sight damage	Joints opened up, crest loss <1m, few half-barrels visible when pre-splitting, excavation possible for 1m beyond designed batter location.
Moderate damage	Blocks dislodged, crest loss 1-3m, excavation possible for 1-3m beyond designed limit.
Severe damage	Face shattered, blocks dislodged and rotated, excavation possible for more than 2m from designed limit.

TABLE 10:
Categories of damage to blasted sections

A detailed record should be made of the post excavation performance of the batter face.

Indications of failure

Even the most carefully designed slopes may be subject to instability. Some of the more common indications of failure are listed below.

TENSION CRACKS

Cracks forming at the top of a slope are an obvious sign of instability. Cracks form when slope material has moved toward the floor. Since this displacement cannot be detected from the floor, it is extremely important to frequently inspect the crests of slopes above active work sites. Safe access should always be maintained to the regions immediately above the active excavation. Frequent inspections may be necessary during periods of heavy rain or spring run-off, and after large blasts.

The simplest method for monitoring tension cracks is to spray paint or flag the ends so that new cracks or propagation along existing cracks can be easily identified on subsequent inspections. Measurement of tension cracks may also be as simple as driving two stakes on either side of the crack and using a survey tape to measure the separations.

SCARPS

Scarps occur where material has moved down in a vertical or nearly vertical fashion.

Material that has moved vertically and the face of the scarp may be unstable and should be monitored accordingly.

ABNORMAL WATER FLOWS

Sudden changes in rainfall or water flow may also precede slope failures. Spring run-off from snow melt or after periods of heavy rain is one of the most obvious examples of increased water flow which may have adverse effects on slopes. But changes in steady flow from dewatering wells or unexplained changes in piezometer readings may also show subsurface movement that has cut through a perched water table or hit a water-bearing structure. Changes in water pressure from drain channel blockage can also trigger slope failures.

Water can also penetrate fractures and accelerate weathering processes. Freeze-thaw cycles cause water-filled joints to expand and loosen slope material. Increased scaling may be necessary during cold weather.

CREEP OR SLOW SUBSURFACE MOVEMENT

Bulging material or 'cattle tracks' appearing on a slope indicate creep or slow subsurface movement of the slope. Other creep indicators can be identified by looking at vegetation in the area. While most quarries or mines do not have vegetation on slope faces, the movement of trees at the crest of a slope can indicate instability.

RUBBLE AT THE TOE

Fresh rubble at the toe of a slope or on the floor of the excavation is an obvious indicator of instability. Work out which portion of the slope failed, and whether more material may fail.

One of the most dangerous situations is an overhang. If workers are not aware that material below them has failed, they may go onto an unsupported ledge. Remedial measures such as scaling, supporting, or blasting the overhang or other hazardous rock may be necessary.

10.4 Slope movement monitoring programmes

Provide enough suitable slope movement monitoring as required by a geotechnical assessment or risk assessment to detect instability early, so safety measures can be taken in time. Monitoring 'after the fact' does little to undo damage caused by unexpected failures.

The ground or strata instability PHMP must cover the appropriate equipment and procedures to monitor, record, interpret and analyse data about seismic activity and its impact on the operation. It must also include collection, analysis and interpretation of relevant geotechnical data and monitoring openings and excavations where appropriate.

The purpose of a slope movement monitoring programme is to:

- maintain safe operational practices for the protection of workers, equipment, and facilities
- provide warning of instability so action can be taken to minimise the impact of slope movement
- provide crucial geotechnical information to analyse the slope failure mechanism
- design the appropriate corrective measures.

When planning a slope movement monitoring programme, consider:

- defining site conditions
- predicting all potential mechanisms to control instability
- setting parameters to be monitored and consequence of not keeping within set parameters
- establishing suitable monitoring systems, including instrumentation and location
- formulating measurement procedures, including frequency, data collection, processing, interpretation and reporting
- assign tasks for design, construction, and operation of systems
- plan regular calibration and maintenance
- establish trigger action response plans (TARPs) and associated accountabilities for action to minimise impacts of slope movement.

Slope monitoring methods can be surface or subsurface and either qualitative or quantitative. All have their place in specific environments and are often related to potential failure size. Select the most appropriate technique depending on site-specific conditions.

Monitoring methods

The instruments selected for a slope monitoring programme depend on the particular problems that need monitoring. A comprehensive monitoring system may include instruments capable of measuring rock mass displacement, ground water parameters, and blast vibration levels.

When selecting monitoring instruments, incorporate some level of redundancy in the system to cross-check instrument performance and eliminate errors. Redundant or over-lapping measurements also provide a back-up if an instrument fails.

Automated equipment is generally more accurate than manual equipment since some human error is removed. Automated systems also provide added flexibility in the sampling rate and can therefore monitor more frequently than manual readings. Another advantage is their ability to trigger alarms if certain thresholds are reached.

Instruments should be placed where they will be the most effective. Estimating the movement expected in a particular area should help make sure the instrument's limits are not exceeded. There may also be environmental limitations (such as extreme heat or cold) that determine whether a particular instrument will work at a specific site. All these factors should be evaluated against the primary objectives of the monitoring programme.

VISUAL INSPECTION

A basic element of a slope movement monitoring programme should be visual inspection by a competent person, with observation by all workers. Maintain this qualitative, but extremely important aspect of the programme throughout the life of the operation.

Workers should report rock falls, be involved in slope inspections and regular detailed inspections.

Any visual monitoring programme should be supported by instruments to provide a quantitative basis for defining any movement.

Develop and implement a procedure for the regular inspection of faces above every place of work and every road used by workers.

You must make sure:

- a competent person examines every area of the operation where a worker is present, or will be present, before every shift, and at suitable times during the shift
- every accessible area of the site (including areas containing barriers, machinery and infrastructure) is examined at least weekly.

It must also make sure that written procedures are included in the HSMS, setting out:

- what to examine
- when to examine
- how to record inspections
- how to action results.

Practical information and advice on actions to take when defects are identified may include:

- if it is safe to work below and above a face
- if there is any loose material on the face
- if there is potential for instability
- whether maintenance is required to the face before starting work
- when further advice is needed, such as from the geotechnical specialist.

SURFACE EXTENSOMETERS AND CRACK MONITORING

If evidence of movement is detected from visual inspection, the first step to increase the monitoring programme could be simple crack monitoring. Results of visual inspections and crack monitoring are useful when selecting additional secondary monitoring points for detailed survey assessments.

Crack monitoring techniques typically consist of:

- regular detailed mapping of location, depth, width of cracks, rate of extension and opening
- installation of targets on opposite sides of cracks to monitor rates of opening
- installation of surface (wireline) extensometers
- installation of picket lines or a line of targets to monitor using theodolites or precise levels to detect changes in alignment, and location of elevation along a given crack or the crest of the slope.

Surface extensometers for monitoring local wall movement or tip movement can be easily constructed. They provide a rugged practical system of monitoring that can be inspected and interpreted regularly by operational workers. They can also be equipped with automatic devices such as lights or sirens to provide excessive movement warnings. More sophisticated units can provide real-time indications of movement to remote locations (such as offices) through a telemetric link.

TERRESTRIAL GEODETIC SURVEYS

The most reliable and complete measurements associated with initial movement can be obtained from conventional geodetic survey techniques, using precise theodolite and electro-optic distance measuring (EDM) combinations or total stations. These systems can be installed by survey workers, generally with survey equipment in regular use at a site.

Primary monitoring points should be surveyed at regular intervals, consistent with the type of rock and expected rates of movement.

Surveillance monitoring frequencies vary from weekly to quarterly depending on conditions such as the stage of mining or extraction, mining or extraction rate, changes in piezometric surface, and climatic variations.

The individual aspects of a typical system are:

- Control points for the system should consist of the instrument stations near the crest of a slope and reference stations located away (100m to 3km) from mining or quarrying activities. Control points are usually established by conducting a first-order survey, using conventional survey techniques such as triangulation, trilateration or triangulation, or GPS.
- GPS is much more efficient, accurate, and less labour-intensive than the conventional survey techniques when used for control surveys, especially when the network covers a relatively large area. The main requirements are that the system used picks up variances and good quality equipment.
- The stability of instrument stations can be checked by resurveying the control network or reference stations each time the instrument station is used. Make sure reference stations are observed regularly.

Plot and assess data from the survey after each set of readings. If movement is detected, monitoring frequency of secondary points will depend on the size of the failure and movement rates, and could be hourly to weekly.

GPS STATIONS

Global positioning systems (GPS) can be used for real-time positioning at any location 24 hours a day, in any weather. Positioning is accomplished using timing signals transmitted by the satellites to ground receivers.

With two or more receivers working simultaneously in a so-called differential mode, you can measure relative positions (3D coordinate differences) between the receivers. This will be accurate from a few millimetres to about 20mm, over distances up to several kilometres.

Unlike conventional survey techniques (such as those using EDM, total stations, and levels) GPS does not need a direct line of sight between survey stations. If the GPS base line length is within 1km, it is not affected by local atmospheric conditions. So, they are usually more efficient and accurate and require less labour than conventional survey techniques. Therefore, GPS was adopted as the general surveying technique at many extractives sites. They are also an ideal tool for setting up control surveys to monitor slopes.

RADAR

Where more extensive areas of movement are detected, radar enables real-time monitoring of the movements to help make sure workers remain safe below the slope. Radar units used in conjunction with geodetic surveying can effectively provide real-time warning of movements and accelerations.

It is important that radar is not the sole basis for monitoring. It is also essential to maintain a degree of conservatism when deciding to withdraw workers from below a moving slope, even if it is being monitored by radar. Even small rock falls from the deformation can have serious safety consequences and may not be detected by radar.

SUBSURFACE TECHNIQUES

Costs of subsurface techniques are greater than those for surface instrumentation. These costs can be modest, if available drilling equipment is used, and workers perform the installation after instruction from specialists or the instrument supplier. For example, inclinometers and TDR cables, give very valuable and precise information on the locations of deep-seated slide surfaces, and on rates of movement needed to properly plan remedial work cannot be adequately planned.

MICRO-SEISMIC MONITORING

Routine, real-time micro-seismic monitoring in opencast environments can provide 3D data where rock breakage or movement is occurring. The data can be used to enhance surface monitoring systems to identify potential instability and the associated failure mode. The technique is commonly used in underground mining operations and has recently been applied in opencast environments.

MONITORING OF GROUNDWATER PRESSURE

If the slope design is based on achieving a given future pore pressure profile, it is important year-by-year pore pressure targets are developed to make sure depressurisation is occurring at the desired rate.

Include piezometer installations in the most critical areas for slope performance in the final slope design. Target pressures are then developed for each piezometer, for each year of operation.

The components of a groundwater monitoring system could include:

- data acquisition systems
- piezometers
- horizontal drain flows
- dewatering well discharges
- monitoring of slope conditions.

Instrumentation data

A detailed draft of monitoring and reporting procedures should be prepared during the planning phase, then finalised after the instruments are installed. Then, responsible workers will be familiar with instrument operation and specific site considerations.

These procedures should include:

- a data collection list
- equipment specifications, including servicing requirements
- processing and presentation procedures
- interpretation procedures, including alarm levels.

A competent geotechnical engineer or instrumentation specialist, selected by the site, is responsible for collection of instrumentation data determined during the planning phase.

PROCESSING AND PRESENTATION OF INSTRUMENTATION DATA

The primary aim of data processing and presentation is a rapid assessment of information to detect changes that require immediate action. A secondary function is to summarise and present the data to show trends and compare observed with predicted behaviour, so any necessary action can be initiated.

Present monitoring data in a format that is easy to read and identifies problem areas quickly.

During the planning phase, decide who is responsible for processing and presenting instrumentation data. It should be directly controlled by a competent person on site, or in special cases, consultants who have immediate 24-hour access to the data.

The time needed for these tasks can be underestimated, resulting in accumulated unprocessed data and failure to take appropriate action.

Experienced geotechnical engineers may use much of their time supporting monitoring systems instead of delegating these responsibilities to technicians. This may mean they neglect the required technical analysis to minimise or manage the impacts of potential slope failures.

The time needed to process and present data is usually similar to, and may even go over, the time needed to collect it.

Data processing and presentation depends on the specific monitoring system. For surveillance monitoring and small slopes, it can often be done with standard spreadsheets. Comprehensive monitoring programmes may require commercial survey reduction and geographic information system (GIS) programmes.

INTERPRETATION OF INSTRUMENTATION DATA

Monitoring programmes have previously failed because the data was never used. A clear sense of purpose for a monitoring programme helps, guide data interpretation.

Use early data interpretation to check the accuracy of the monitoring system. For example, atmospheric changes may result in diurnal variations of several times the manufacturer's quoted accuracy for EDM and total station units. This is common particularly in climates where there are significant temperature differences between day and night, or climates where temperature inversions can develop in a pit overnight.

Filter out these survey accuracy variations as part of the interpretation process, either by setting wider bands before alarms are triggered or by emphasising on readings taken at the same time of the day.

The purpose of subsequent data interpretation is to correlate the instrument readings with other factors (cause and effect relationships), and to study the deviation of the readings from the predicted behaviour.

RESPONDING TO DATA VARIATIONS

Interpretation of data from movement monitoring systems primarily involves assessing the onset of changes in the movement rate. This is generally reflected by acceleration but, where a slope is already moving, deceleration may also occur.

If the material does fail, the site should have a pre-planned response to the movement. This can be done by using trigger points or trigger action responses (TARPs) for each monitoring method.

The reporting procedure in the event of any TARP should be clearly defined and understood by everyone. Slope failures rarely occur without some warning, and it is important workers can recognise potential hazards and act accordingly. It is recommended TARPs also include actions to take if monitoring systems or instruments no longer operate correctly.

REPORTING CONCLUSIONS

After interpreting each set of data, report conclusions in an interim monitoring report and give it to the workers responsible for implementing remedial actions.

At the very least, supply management with a monthly summary report of monitoring results, even if no movement is detected.

A final report is often needed, and a technical paper may be prepared.

10.5 Working near slopes

Manage hazards from individual rocks falling from a slope (highwall or face) using a mix of techniques. These include:

- support or control the fall path of potentially loose rock
- scale the loose rock
- provide rock catching berms, benches, or both
- limit workers' exposure to areas with loose rock on the slope.

Before work starts near a slope, inspect it thoroughly for hazards, including loose rock. If loose rock is identified, scale it off the slope or cordon the area beneath the loose rock. Benching and moving roadways or work areas away from the base, can also reduce exposure. Mobile plant should work perpendicular to the base of the slope to give operators a better view of the face.

Put the following control measures in place when working near slopes:

- A bench in the slope above the work area. Space it so you can clean the face below (from the floor to the first bench) using mobile plant or equipment available on site.
- Workers should not be positioned between the slope and any mobile plant or equipment that could block their escape.

- Provide safe access to the top of the slope for ground condition checks.
- Clear the top of the slope of loose, hazardous material before bringing down the shot material exposing the face. Use mobile plant (such as an excavator), that can reach the edge of the wall from a safe staging point. Use the bucket's outward force to remove loose material from the top edge of the wall.
- Keep workers a safe distance from the toe of the wall using a buffer. This may include placing the loading excavator on a rock platform with a rock trap (or trench) between the excavator and the face (see Figure 42).
- Mobile plant should operate perpendicular to the face or toe while in the impact zone.

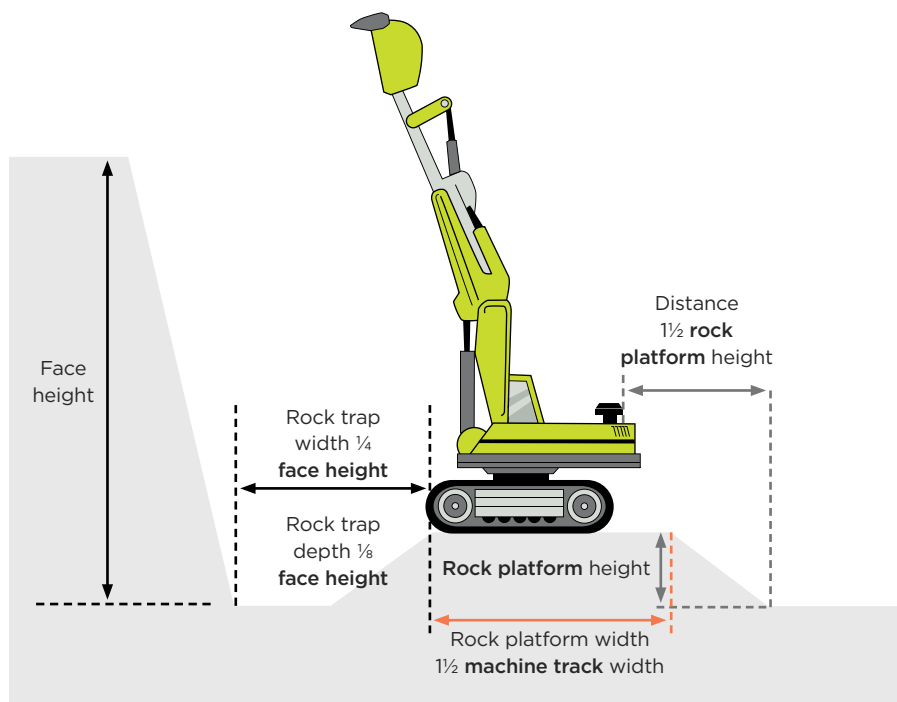

FIGURE 42:
Rock trap design

10.6 Remedial measures

The remedial measures taken after slope movement depends on the type of instability and how it affects operations. Each case should be assessed separately for safety, site plans and cost-benefit analyses.

Stabilisation and repair methods are used when ground movement has already occurred where artificial support methods are used to prevent instability.

LET THE MATERIAL FAIL

If a failure is in a non-critical area of the excavation, the easiest response may be to leave the material in place. Work can continue at a controlled rate if the velocity of the failure is low and predictable, and the failure mechanism is well understood. However, if there are any questions about the subsequent stability, try to remove the material.

To prevent small-scale failures from reaching the floor of the excavation, both the number and width of benches can be increased. Catch fences can also be installed to contain falling material.

SUPPORT THE MATERIAL

If letting the instability fail is not an option, a solution may be to artificially support the failure. Some operations have successfully used reinforcement such as bolts, cables, mesh, and shotcrete to support rock mass. These can be very expensive but may be worthwhile if it enables a steeper batter angle or reduces clean-up costs.

A careful study of the geological structures should be done to select the proper reinforcement (such as length of bolts or cables, thickness of shotcrete). Bolts that are too short will not do much to prevent slope stability problems from continuing. In some cases, reinforcement has only served to tie several small failures together, creating a larger failure.

Another potential solution to stop or slow down ground movement is to build a buttress at the toe of the slope. The buttress offsets or counters the driving forces by increasing the resisting force. Short hauls of waste-rock often make this an effective and economical alternative for stabilising slope failures.

REMOVE THE HAZARD

If a slope keeps failing, and supporting the slope is not possible, you should remove the hazard. Flattening the slope to a more stable angle for local geology will often solve the problem. If catchment systems are not in place, use appropriate scaling methods regularly to remove hazards from small rockfalls.

Removing, or unweighting, the top of a slide may reduce the driving forces and stabilise the area. However, this approach is usually unsuccessful and, in some situations, involving high water pressure, unloading decreases the stability of the remaining material.

Water pressure often causes slope stability problems. Dewatering using horizontal or vertical wells can be a significant way of controlling slope behaviour and minimising hazards. Surface drainage and diversions should also be used to keep surface runoff away from tension cracks and open rock mass discontinuities near the slope face.

Installation of artificial ground support and reinforcement

If artificial ground support and reinforcement are part of the slope design, they must be installed correctly. The timing of installation is a key part of the design. For more detailed information on ground support and reinforcement systems see Section 6.8.

Some installation tasks, like shotcreting or drilling, can be done from a safe distance. But installing mesh and bolts, such as plating and tensioning, can expose workers to much greater rockfall hazards than usual.

These increased safety risks during installation must be clearly understood and managed. No worker should enter an area with unsupported ground unless they are installing or supervising the installation of ground support or carrying out or supervising slope stabilisation.

Temporary support must be provided to protect workers from hazards caused by unsupported ground or unstable strata when they install or supervise the ground support installation or undertake or supervise slope stabilisation.

Managers must make sure suitable ground or rock support, or slope stabilisation, is designed and put in place for all work areas. Plans showing these arrangements must be displayed where all workers can easily access them.

Consider the following when installing artificial ground support and reinforcement:

STORAGE AND HANDLING

- Store and handle artificial ground support and reinforcement products to minimise damage or deterioration.
- Clean steel components designed to be encapsulated in resin or cement grout of oil, grease, fill, loose, flaking rust, and any other materials which may damage the grout.

GROUT AND OTHER ADDITIVES

- Mix grout according to the manufacturers or supplier's instructions including cement to water ratio, correct mixing time and speed and water quality.
- Add any additives (for example, retarders, accelerators, or fluidisers) to the grout mix in the recommended amounts and at the specified time in the mixing and pumping process.
- For full ground encapsulation of steel elements, the method of grouting should show a grout return at the collar of the hole. Other methods that can demonstrate complete hole filling may also be appropriate. All grout mixing and pumping equipment should be cleaned and maintained regularly.

PROCEDURES DURING INSTALLATION

Procedures for artificial ground support and reinforcement installation should include:

- the method of work
- the support materials and equipment to use
- the layout and dimensions of the artificial ground support and reinforcement system
- any method of temporary support necessary to secure safety
- the procedures for dealing with abnormal conditions
- the method and equipment for withdrawal of support
- manufacturer's instructions relevant to the safe use of support
- information on other hazards such as known zones of weakness, or proximity to other workings or boreholes
- the area the procedures apply to, and the date they became effective.

Use correct tensioning procedures when required, for the various artificial ground supports and reinforcement. The reason for tensioning cables should be clear to decide if post or pre-tensioning is needed.

Also consider:

- the hole's orientation should fit the shape and expected mode of failure
- plates or straps on the rock surface should be thick enough to prevent nuts being pulled through the plate or strap when loaded against the rock surrounding the hole
- shotcrete thickness should be checked regularly during placement to make sure it meets the required thickness. Marking the shotcrete surface with a depth gauge probe may help.

Samples of the shotcrete mix should be taken at set times during normal work. They should be tested in an approved concrete laboratory to check they meet the shotcrete design specifications. Tests should include the slump, the uniaxial compressive strength and toughness of the product.

PROCEDURES FOLLOWING INSTALLATION

Use monitoring arrangements to make sure the artificial ground support or reinforcement system remains effective, including monitoring for corrosion.

10.7 Preventing falls from highwalls or faces

Any person who works on or near the edges of faces or highwalls has the potential to fall. Typically these are the driller, shotfirer and person carrying out the daily inspection. Other people potentially working on or near edges include surveyors, engineers, explosives truck workers, planners, geologists, geotechnical engineers and fencers.

You must first try to eliminate a risk if this is reasonably practicable, otherwise minimise the risks as described in the hierarchy of control measures (see Figure 1). A hierarchy of control for the hazard of working near highwalls or faces is:

1. A windrow, a fence or other physical barrier capable of supporting a person's weight if they fall against it should be in place along the edge (see Figure 43).
2. If a barrier is not practicable, you should determine a distance from the edge that is safe to work and demarcate this area with a fence (for example, para-webbing fence or waratah wire type fencing). The safe distance should be a minimum of 2m (see Figure 44).

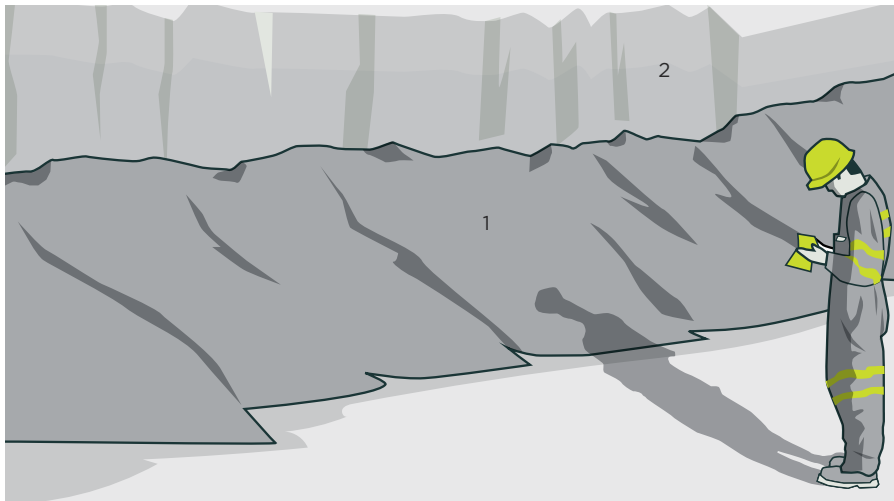

1 Windrow
2 Highwall

FIGURE 43:
Example of a pedestrian windrow

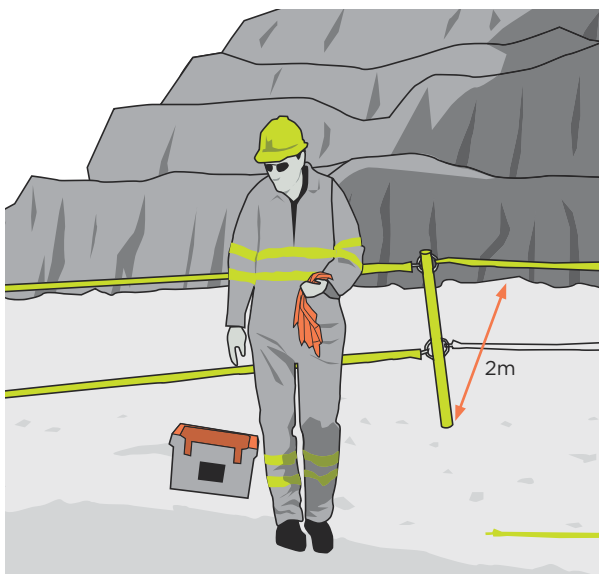

FIGURE 44:
Example of non-weight supportive barriers

When installing or removing any barrier other than a windrow, provide a travel restraint system such as a harness. Connect this harness to a fixed position that restricts workers' ability to work outside the safe area (see Figure 47).

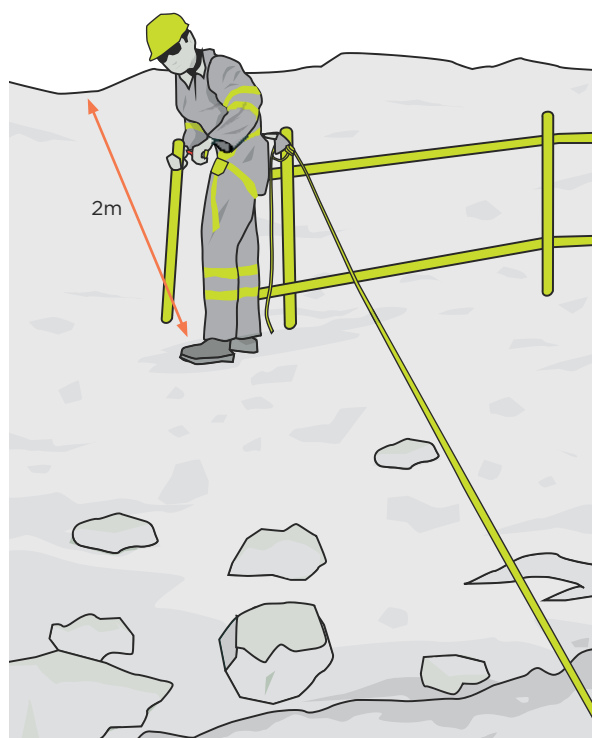

FIGURE 45:
Example of fall
restraint system

A risk assessment should be carried out to establish a safe system of work for any person likely to be in a position where they may fall from a face. Consider the geology and stability of the face, the ground conditions, weather, lighting equipment being used, the need to adjust burdens, marking hold positions and profiling.

Windrows are preferable to other less substantial barriers but may hide cracks or signs of instability along the edge. Windrows should be:

- constructed only after inspection of the area below. Faces need to be inspected for faults, change in appearance, loose surface, evidence of falling rocks, water seepage, joints and cracks
- constructed a metre or two from the edge where possible so any cracks or deterioration of the edge can be seen
- constructed from suitable material to avoid trip hazards
- a minimum height of 1m (for pedestrian protection only)
- regularly inspected and maintained.

Workers should be trained in the appropriate selection and use of harnesses before starting work. Make sure workers are closely supervised until assessed as competent.

Vehicles should not be parked under high walls, due to the hazard of rock falls.

10.8 Historic underground workings

Sites may mine or extract materials that were mined underground before. There are serious risks that can arise when opencast mines or quarries get close to, and then mine or extract through underground workings. Voids may be hidden in the area being mined. This is a principal hazard and a PHMP for voids must be created.

Other hazards include:

- sudden and unexpected collapse of the ground or walls
- losing people or equipment into unfilled or partially filled underground workings
- losing explosives from charged blastholes that break through into the underground workings
- overcharging blastholes where explosives fill cavities connected to the blasthole
- risk of ejecta (such as fly rock) from cavities close to the floor and adjacent blastholes, particularly when explosives have entered the cavity from the blasthole during charging and the loss is not detected.

In general, these hazards significantly increase when underground workings are not backfilled during mining. Because these hazards are usually not obvious during normal operations, take extra steps to understand their nature and how far they reach.

Hazard identification of underground workings

It is essential to thoroughly review previous mine plans before development.

Old underground mine plans should be carefully checked, especially if they are copies or summaries of the originals. While this helps to assess the likelihood of abandoned underground workings near an open pit, you cannot fully rely on their accuracy.

Reviewing underground workings should be part of design and site planning to make sure, as far as reasonably practicable, that:

- all known underground workings are marked clearly on all working plans and the plans are rechecked
- there is recognition that the rock mass surrounding the underground workings may be highly variable in strength and potentially unstable
- a three-dimensional model of underground workings is developed and used in all design, planning and scheduling.

Update all plans after each exploration phase to record the revised outlines of the actual size and shape of underground workings.

If underground workings are unlikely to be large or no plans are available, it may be necessary to confirm their location.

Several detection methods which may be used to confirm the lateral extent and shape of underground workings, include:

- probe drilling
- geophysical techniques (including seismic, resistivity, conductivity, and gravity methods)
- ground probing radar
- laser-based electronic distance measurement (EDM) surveying methods
- closed-circuit television (CCTV) cameras lowered through probe holes
- where practicable, an actual physical inspection and survey.

Once the relevant hazards have been adequately defined, the PHMP must describe control measures to manage the principal hazard and the risk of harm to workers.

Risk control

Consider the following control measures to eliminate or minimise the risk of unexpected floor or wall collapse:

- place fill materials into underground workings
- leave a reasonably sized pillar between the current working bench and the underground workings by stowing or collapsing
- restrict work away from the suspect location, allowing an adequate safety margin
- blast waste rock into voids, then further back fill to stabilise the area.

If there is a risk of intersecting underground workings, a geotechnical assessment should be carried out to determine the minimum stable floor pillar or rib pillar dimensions.

Clearly mark all areas of a working bench likely to be underlain by underground workings, and control access using a specific set of procedures. These procedures should cover a range of issues including:

- minimising pedestrian movement
- identifying the workers responsible for monitoring and marking out the hazardous areas
- probe drilling procedures
- marking the extent of underground workings
- drilling and blasting
- plant and equipment movement
- placing fill materials in unfilled workings
- monitoring rock stability
- daylight and night operations
- plant and equipment specifications
- regularly sharing information and discussing concerns with those involved
- review of the procedures as the pit depth increases.

Allow for uncertainty in the exact location of underground workings and any potentially unstable ground around them. Add an extra margin of safety between work areas and suspect zones.

If using extraction approaches in operating underground mines, potential hazards may include:

- flooding of underground workings
- instability of slopes and surrounding surface areas
- negative impacts on underground mine ventilation systems
- spontaneous combustion
- collapse of unfilled stope voids
- lack of coordination, communication, and control of mining activities between the surface and underground mines.

You must identify hazards that could lead to reasonably foreseeable health and safety risks. Put control measures in place to first try to eliminate the risk if reasonably practicable, otherwise, minimise the risk so far as is reasonably practicable.

11.0

Tipping (or dumping)

IN THIS SECTION:

- 11.1 Dumping and tipping methods
- 11.2 Controlling end-tipping risks
- 11.3 Suggested control measures
- 11.4 Procedures for examining tip heads
- 11.5 Tip maintenance and inspection
- 11.6 Other considerations for stockpiles
- 11.7 Reworking or reshaping tips

Instability or movement in tips and stockpiles can cause serious harm. To minimise this risk, actively manage tips and stockpiles, and have robust procedures in place.

This section describes:

- risks and suggested control measures for tips and tipping
- inspection processes for tip heads and tip conditions.

Incidents can occur for various reasons when tipping or dumping, mainly because of unsafe tip head conditions or design, unsafe dumping or tipping practices, or some combination of these.

Tipping risks include:

- no windrow or restraint, or an inadequate windrow or restraint, which makes the edge location difficult to judge, and offers inadequate restraint to keep a vehicle from going over the edge
- inadequately compacted tip edges that may not support the weight of mobile plant using the tip
- a tip that runs downgrade to the windrow, which gives drivers less control while reversing, and can soften the dump area from poor drainage
- inadequate lighting for night operations, or poor visibility during inclement weather, which may impact driver judgement and detection of unsafe conditions
- inadequate clearance between equipment and overhead power lines, in particular when truck trays are raised at dump points and when tips get larger so clearance may be gradually reduced
- congestion around the tip head where dump trucks or other mobile machinery crowd the tip head due to operational delays or unplanned events.

11.1 Dumping and tipping methods

There are three methods of offloading material from a truck:

- **Paddock dumping** where loads are dumped close to each other and, if another layer is to be built on top, the surface is levelled and prepared for the next lift using mobile plant.
- **Dump short and push off** where loads are dumped and pushed off a tip edge while leaving the windrow in place.
- **End-tipping** where loads are dumped down a free face and the load slides down requiring regular maintenance and re-building of windrows.

Paddock dumping or dumping short and pushing off are the preferred options for all tips. This is because these methods generally reduce the risk of vehicles driving off an edge or the edge collapsing due to increased weight from vehicles. Under carefully managed circumstances end-tipping can be done safely.

11.2 Controlling end-tipping risks

Whenever heavy vehicles are operated near the edge of a slope, there is a risk that the edge material will not support the vehicles. This is especially relevant on tips or stockpiles where the material is normally in a relatively loose condition.

In a tip or stockpile the material is typically at its 'angle of repose'. The angle of repose is the angle at which the material rests when dumped in a pile. This angle will vary depending on the size and shape of the constituent particles, how the material is dumped and the amount of moisture in the material when it is dumped.

For a pile of material at its angle of repose, the edge of the pile is marginally stable. When dumped or pushed over the edge, the material tends to slide until it comes to rest at an angle where it can barely support its own weight. This is why it is hazardous to bring the heavy weight of a truck close to the edge of an angle of repose slope. When this occurs, the slope material has to support not only its own weight, but also the additional weight of the loaded truck. If the additional weight of the truck causes the material's shear strength to be exceeded, the edge of the slope will give way under the weight of the truck. This risk is increased when the load is raised, and additional weight is transferred onto the rear wheels. This is why serious incidents keep happening at uncontrolled tip heads. For an example of tip design, see Figure 46.

The edge of a pile can also become unstable if the foundation cannot support the weight of the material and begins to give way. Especially in a tip of overburden, the edge may become unstable because of a zone of weak material in the tip. Sliding may occur on a layer of the material.

Because the tip head must be capable of supporting the weight of the vehicles being used, usually a truck, and withstand the other dynamic forces imposed in stopping and dumping near the edge, competent engineering advice may be required to design the tip.

End-tipping should therefore only be done where the following risk mitigation measures are in place and maintained:

- A geotechnical assessment of every tip with a minimum factor of safety (FOS) of 1.2 (see Section 6.7 for more information).
- Tips and tip heads (including windrows) should be designed (with drawings, see figure 46 for an example); formed from consolidated layers; and terraced or stepped back to minimise fall risks.
- The edge and windrows should be systematically maintained while end-tipping.
- The windrow should be used as a visual guide only. The windrow should not be used to help stop the truck but only as a visual guide to judge where to stop.
- There is adequate supervision of dumping operations to make sure unsafe conditions are being corrected and safe practices are being followed.
- There are specified intervals for reviewing the end-tipping and auditing of the processes.
- Unusual material (for example weaker or wetter) should always be treated differently than standard overburden. Unusual material should always be paddock dumped in an area where it will not compromise tip stability.

Track-dozers are preferred for maintaining tip heads because they distribute the weight of the mobile plant over a greater area than a rubber-tyred dozer, which decreases ground pressure.

When dumping short, a good rule of thumb is to dump one truck-length back from the edge. The benefit of using this method is that the truck drivers are not exposed to the risks at the edge of the tip.

To prevent trucks reversing into water, only backfill water-filled areas by the dump short and push off method.

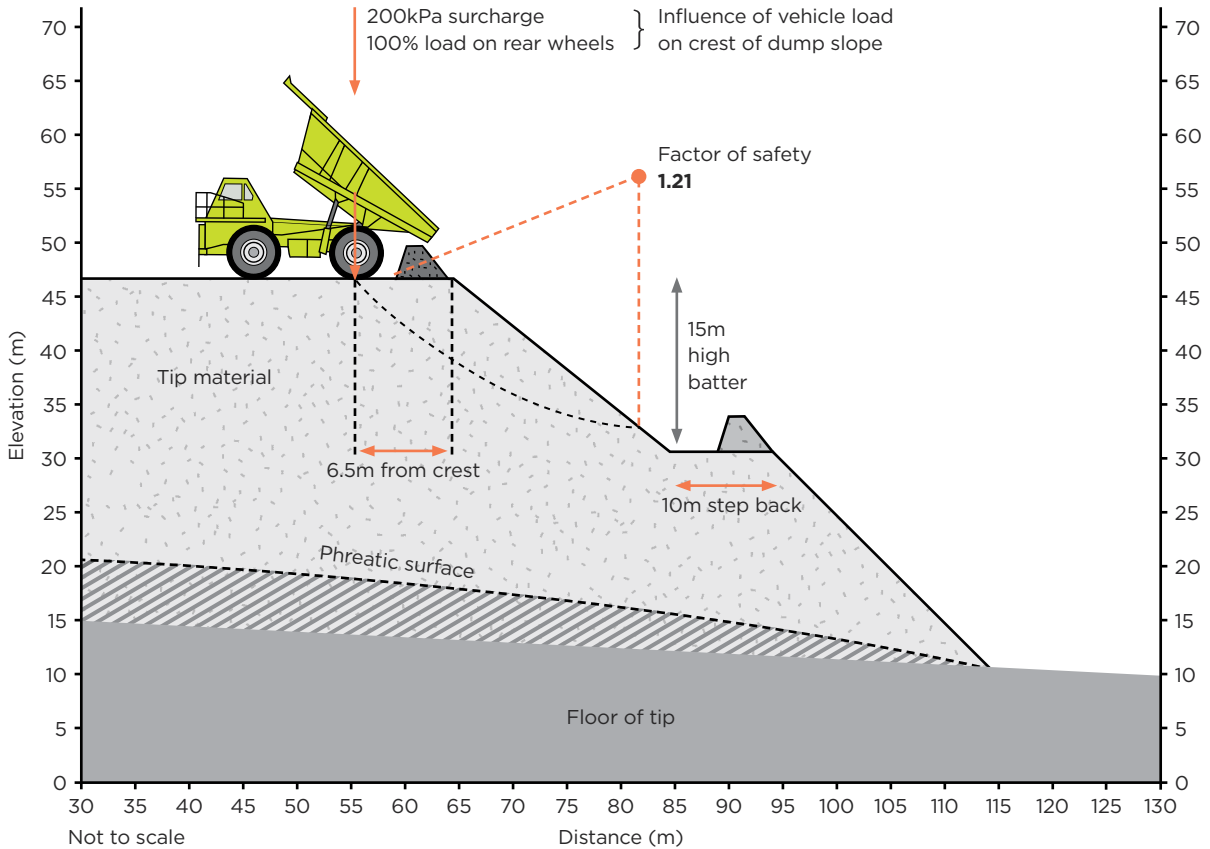

FIGURE 46: Example of tip slope stability design (limit equilibrium)

Tip construction procedure

All tips should have a construction procedure to follow when dumping. This procedure should:

- describe how the tip design, from the geotechnical assessment, will be implemented by the workers
- specify the overall slope angle, maximum heights of batter slopes and minimum bench widths
- consider the type of material being dumped and the dumping method
- consider the size and type of vehicles being used
- include windrow specifications (see Section 8.3 for more information)
- be easily understood by workers.

Workers should be trained in the procedure and dumping should be monitored, to ensure the procedure is being followed.

Using diagrams is a good way to communicate the procedure to workers. Figures 47 and 48 are examples of easily understood tip construction procedures that describe how the tip design from the geotechnical assessment will be implemented.

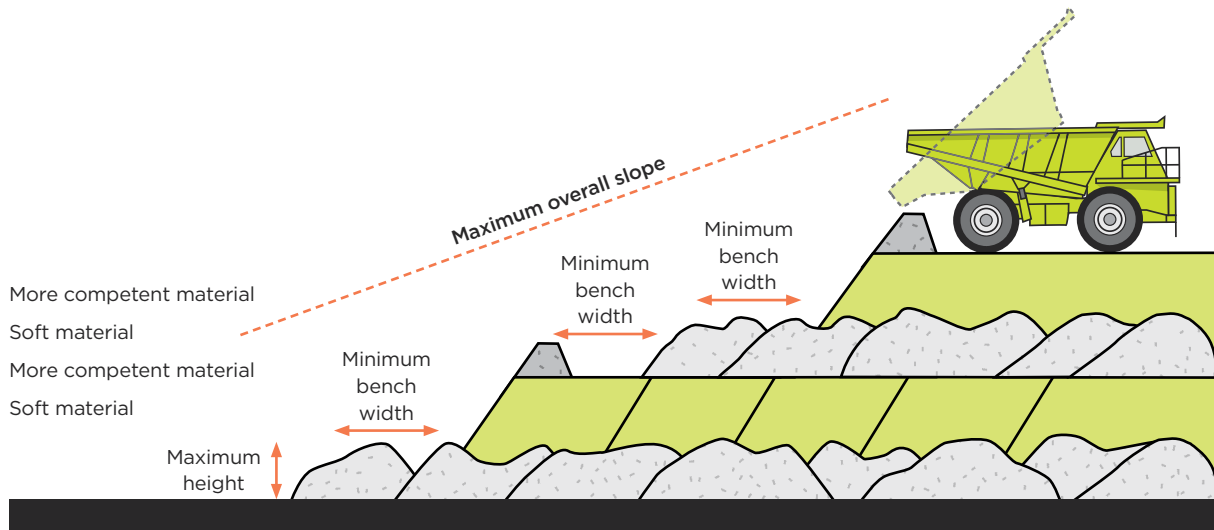

FIGURE 47: Example dump construction method for mixed material (mattressing)

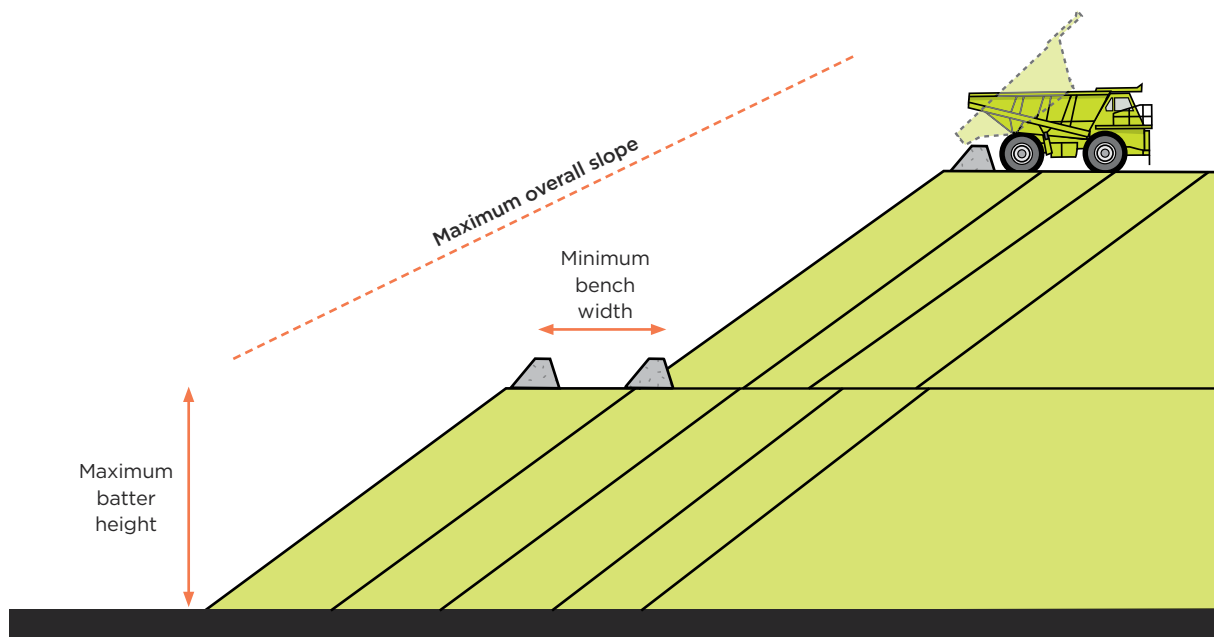

FIGURE 48: Example dump construction method for competent material

These are only two potential dump construction methods. The procedure that the mine follows should be based on the geotechnical assessment.

Dumping methodology

Loads should be dumped in phases according to the design to ensure stability and to allow the tip face to be built out uniformly. A phase is a series of dumps whereby progressive loads are dumped adjacent to the previous one (see Figure 49).

At the end of each phase the tip surface, edge and windrow should be reformed (taking into consideration any compaction or movement of the windrow that is required) before the next phase starts.

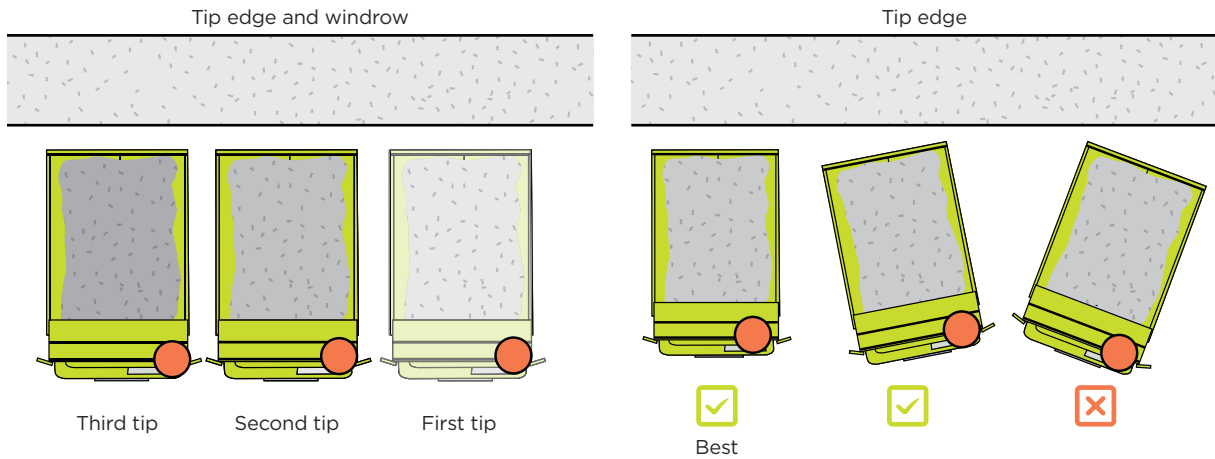

FIGURE 49: Dumping sequence

There should be communication between the mobile plant operators and the truck drivers to advise when the next phase can start.

When reversing close to the edge of a tip, drivers should reverse slowly and come to a gradual stop at the tip head. As a truck reverses up and the brakes are applied, dynamic forces are produced which push down and out on the tip. The more abruptly a vehicle stops, the higher these forces are. These forces can make a stable edge give way.

Drivers should reverse perpendicular to the edge, or with the driver's side tyres leading just slightly (see Figure 50). In many tip head accidents, the tyre tracks have revealed the truck was reversing at an angle, with the rear tyres opposite the driver leading. In these cases, the driver's side mirror would have indicated the driver still had a distance to back up, while the opposite side rear tyres were already contacting the windrow or going over the edge.

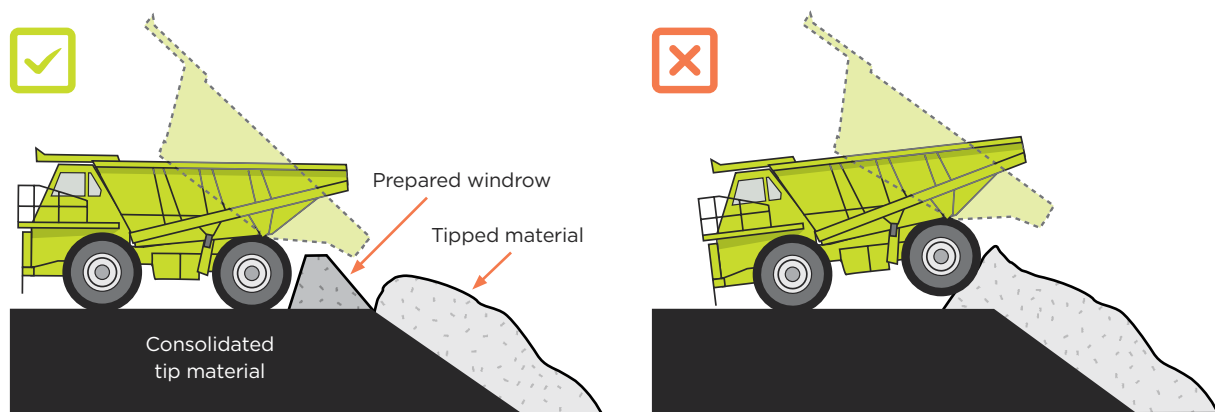

FIGURE 50: Approaching tip point windrow

Construction of windrows at tip heads

A critical function of a windrow at a tip head is to keep the heavy load on the rear tyres of the truck from getting too close to the edge. In this respect the height of the windrow is important because the higher the windrow, the wider the base of the windrow. It is this wide base that is critical in keeping the load back from the edge.

Windrows should be seen as an extra safety control measure and should not be used as a brake or even an indicator that the edge has been reached. They should be designed, constructed, installed and of sufficient height to offer definite restraint in the event a vehicle accidentally contacts them. While traditional rules of thumb for windrow heights (half the height of the wheel) may be useful, they are often not supported by design calculations and could be inadequate as a safety barrier.

Design parameters for windrow construction should be followed.

Design parameters include:

- using material to construct the windrows that is non-uniform in size, to allow interlocking of particles for greater cohesion and strength
- sloping the outer face of the windrow to its natural angle of repose. The slope should be pushed up steeper on the inner face (but must maintain adequate width)
- the width and distance should be enough to keep the heavy loading on the rear tyres of trucks from getting too close to the edge where the material could give way.

Construction of stop-blocks (or wheel back-stops) at permanent tip heads

When a truck (or loader) dumps off a permanent tip head (for example, into a hopper) adequate stop-blocks should be in place. The stop-block should be designed, constructed, installed and of sufficient height to offer definite restraint. The stop-block should be adequate for the largest vehicles that will use the tip head. Remove spills (including gradual build-up) that accumulate in front of the stop-block as these will reduce the height of the block.

11.3 Suggested control measures

Overhead hazards

Carry out dumping operations clear of overhead hazards such as power lines, pipework and so on. Continuously check for overhead hazards. If a tip or stockpile increases in size, vehicles may gradually begin working closer and closer to overhead hazards that were too far away to be a concern when the tip or stockpile was started.

Visibility of a dump site

Adequate lighting should be provided. The area should be illuminated well enough to allow signs of tip head instability, such as cracks, to be detected. If visibility is poor (for example, due to bad weather), dumping should be stopped or other control measures implemented to maintain safety (for example, trucks should dump back from the edge).

During bad weather (for example, fog), a trigger point should be established that will determine when operations will need to be modified or stopped due to reduced operating parameters. This can include visibility, temperature (freezing), traction on pavements (rain) and wind.

Vehicle manoeuvring

It will usually not be possible to completely avoid reversing trucks where dumping has to happen. However, you should reduce the amount of reversing to as little as possible. For more information on reversing, see Section 14.5. Tip heads should be of sufficient size to permit manoeuvring by the largest equipment that is intended to be used.

Dump-point surfaces

The horizontal surface at the tip head should be kept level from side to side so trucks will not tip on their sides when the tray is raised (see Figure 51).

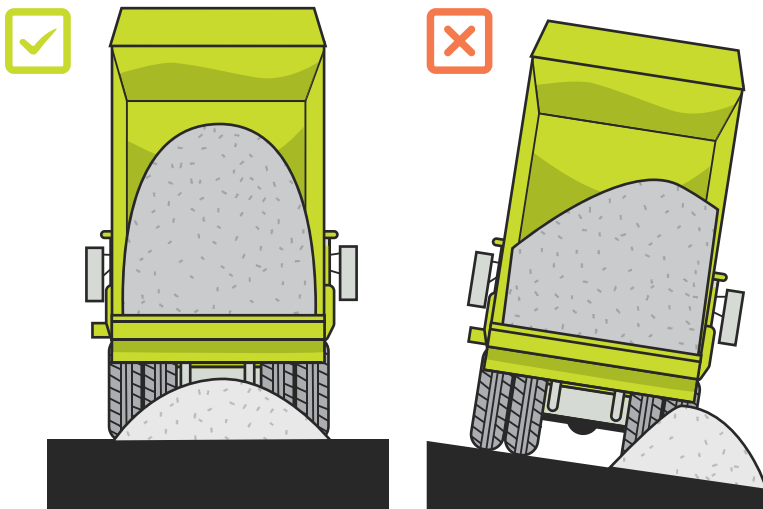

FIGURE 51: Vehicles should be parked on level ground (side to side) when dumping their load

The surface of the tip head should be kept sloped a small amount so, when reversing to the tip head, trucks will be going up a slight grade (see Figure 52). This gives the driver better control. It also provides a better opportunity to get the truck out if any shifting of the ground occurs, as well as keeping the tip head better drained.

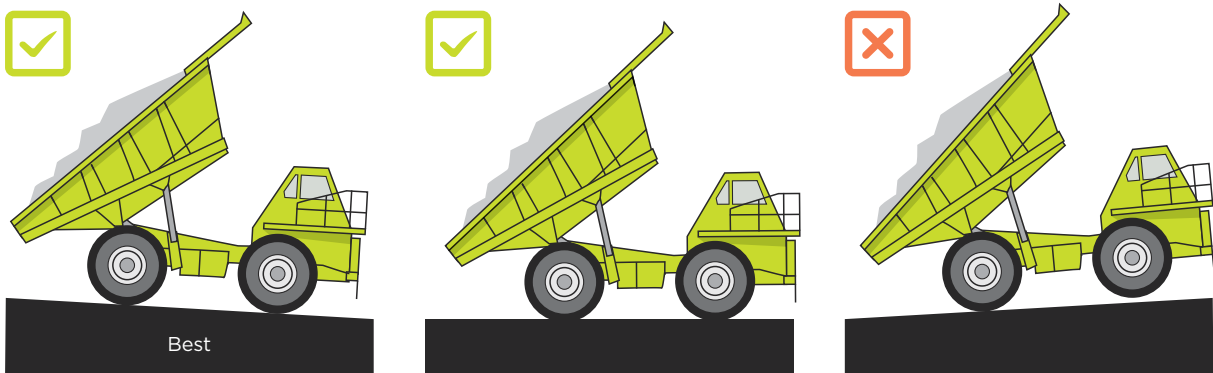

FIGURE 52: Dump on level ground with a slight uphill gradient

Communication

There should be a clear and effective system that allows communication between anyone entering the stockpile or dump area, such as two-way radio.

A protocol should be established to define who is coordinating the tip head. If a dozer is present at the tip head, it is good practice to assign this to the dozer driver. If a dozer driver is not constantly present, then other arrangements should be made where multiple trucks may be present at the same time.

If an excavator is used, position the boom to allow visibility between the operator and trucks.

Using spotters

A spotter is someone who guides a truck into the dumping position, either from a safe viewing platform protected from the elements, or in a stationary vehicle.

A spotter should always 'spot' the truck from the driver's side. Where spotters are used, radios should be provided.

Spotting platforms should be highly visible to all vehicles.

For more information on spotting practices see our guidance [Safe reversing and spotting practices](#)

Using technology

Make use of technologies such as proximity sensors and vehicle-mounted cameras that can improve both tip head safety and efficiency. See Section 14.10.

A rearward facing camera can assist a truck driver in backing up square to the tip head and determining how close to the windrow the vehicle is positioned. They should be provided at all times where end-tipping is undertaken.

Trucks can be fitted with hoist cut-out features if sensors detect that the truck is tipping at an angle that is too steep.

Traffic flow

Consider the types of vehicles entering the tip head when determining a direction of travel (for example, driver cabs may be on the left or the right-hand side). Approaching with the tip head to the driver's cab side gives the driver the best opportunity to check the condition of the tip head just prior to dumping.

Drivers should stay back from the edge a minimum of one truck length on their approach and in making their turn.

Toe exclusion zone (prohibited zone)

A toe exclusion zone should be established at a safe distance from the toe of all working tip and stockpile slopes. Barricade fencing, windrows or traffic cones and warning signs should be erected where there is a risk of harm.

Restricted access for light vehicles and workers on foot

To make sure no additional traffic hazards are introduced there should be restricted access to operational areas of a tip for light vehicles and workers on foot. Signs should be erected indicating restricted access areas.

Where light vehicles are required to access the tip head you should establish dedicated light vehicle parking areas and have protocols in place to eliminate pedestrian and heavy vehicle interaction, stopping operations until pedestrians have left the tip head.

Segregation of vehicles at the tip head

Demarcated routes, for use during night or day, should be provided. This should ideally separate access to and exit from the dumping areas. One-way routes are preferable. By restricting movement to defined routes grading and watering requirements are reduced.

Vehicles in the dumping area should always remain in the view of the driver of a reversing vehicle; that is, on the cab side. Vehicles should remain at least one truck width apart from other vehicles while dumping (see Figure 53). This leaves room in case a truck tips over on its side while attempting to dump. Truck drivers should never drive within the reversing path of another vehicle.

Do not reverse a vehicle blindly in a dumping area. Drivers should make full use of visibility aids and should not reverse until they are certain the path is clear and only if protection is in place adjacent to any edge of a hazard. Safe operating procedures should outline the protocols and rules when working at a tip head.

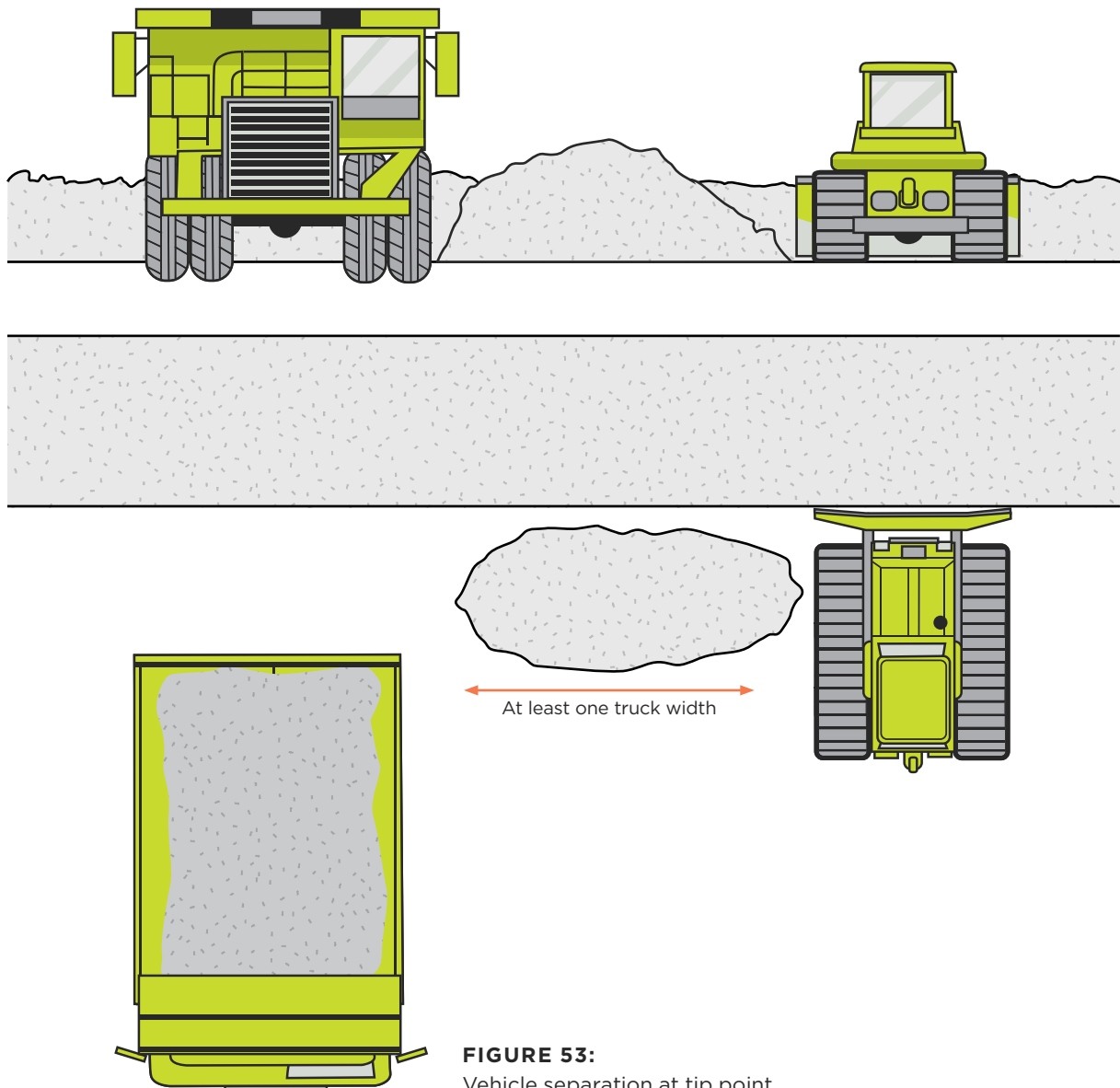

FIGURE 53:
Vehicle separation at tip point

Light vehicles should go to the designated area if there is one. If not, they should stay a nominated distance away from the trucks dumping or queued to dump, similar to having a loading clearance zone. Trucks should queue in a location that ensures they will be safely separated from the dumping truck and in clear view of that truck's operator.

Dumping the load

Drivers should be trained on how to safely handle sticking material (hang-ups). Sticking material can make the truck tip over as the tray is raised or cause a more critical loading condition on the edge of the tip.

If the tray gets to about two-thirds of the way up and material is still sticking, the driver should lower the tray and find another means of getting the material out (using a backhoe).

This risk is more prevalent with road trucks and trailer units. Operators should consider wet weather conditions changing a normally free-flowing load to one that sticks together due to the rain.

When material sticks in the tray, on no account should drivers try to jar it loose by jamming on the brakes as they reverse. The truck could tip over, the tray hoist could fall causing sudden extreme movement, or if this is done near the edge of a tip, the added force could cause the edge to collapse.

A safe system of work should be established for dumping loads. When the truck is positioned, the driver should apply the park brake before putting the transmission into neutral. When the hoist or tray is rising, the truck driver should use the mirrors to watch the material flowing from the tray to ensure there are no side spills or uneven flow (which may indicate a hang-up). Check for cracking or slumping of the tip head.

Raised trays and alignment of articulated vehicles

The vehicle should stay level if it is moved forward during dumping. Driving with the tray raised should be restricted to short distances, and only where it is required to fully discharge a load. Raised tray alarms and built in speed controls can reduce the risk of vehicles being driven with the tray raised.

Always align the tractive unit and trailer of an articulated vehicle when dumping (see Figure 54). Provide enough space for a vehicle to manoeuvre the trailer and cab so they are lined up.

Never jackknife a trailer unit so that there is a risk of the trailer overturning onto the truck.

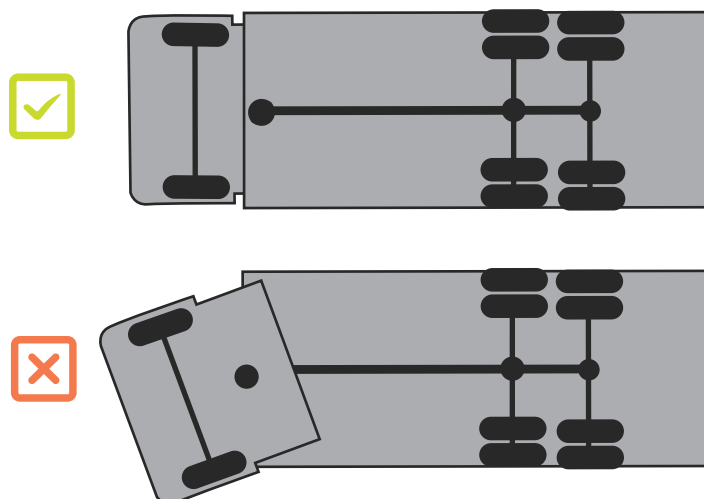

FIGURE 54:
Articulated vehicles

Removing material from a stockpile

The removal of material from the toe of a stockpile can have a significant effect on the stability of the edge.

In the case of loose, free-flowing material, loading out at the toe may have little impact because the material tends to slide back to its angle of repose. Once material has become tightly packed from vehicles on the stockpile, or from sitting for a period of time and settling in, the area where material is loaded out will generally stand at a steeper angle. Material standing at about 35° when dumped over the edge can typically stand at 45° once loaded out.

In some cases, such as when material has been sitting for a long time, the material may stand even steeper or may even stand in an overhanging condition. With these steepened conditions, there is less slope material to support loadings on the stockpile, and a sudden failure could occur.

Mobile plant operators should be trained to continuously trim the face so that it does not overhang and collapse (see Figure 55). Faces should be worked in a straight line so that wings do not develop and create a crescent face which can be self-supporting in the short term but fail suddenly.

Barriers should be installed to restrict access to the top of the tip above the area which is being loaded out. The purpose of the barriers is to isolate the potentially dangerous edge (which could be undercut) from drivers and to eliminate material being dumped onto the loader.

Water saturation of a stockpile can lead to failures and vehicle access should be restricted if this is a factor.

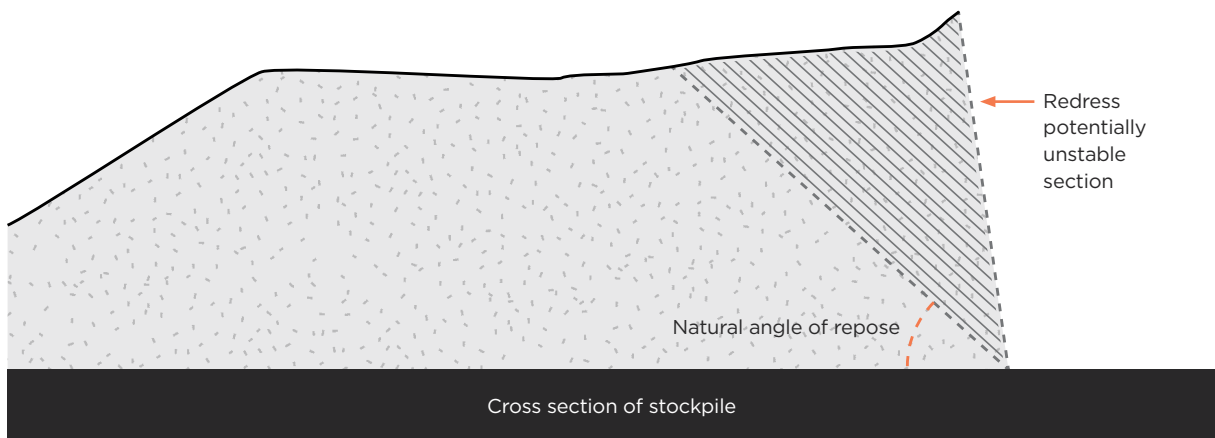

FIGURE 55: Cross section of stockpile

11.4 Procedures for examining tip heads

It is critically important to examine a tip head for unsafe conditions on a regular and on-going basis. Tip head conditions can change due to new material being dumped, the effects of equipment near the tip head, weather conditions, or even just the settling-in of material with the passage of time. In stockpiles, a big factor affecting the tip head condition is the loading-out of material from the toe of the pile.

If the PHMP for tips, ponds, and voids at a mining operation requires regular inspections to be carried out then the PHMP must specify how often inspections occur and a competent person for supervising both tipping operations and inspections.

Operators and supervisors should be trained to identify unsafe conditions and practices at tip heads. They should routinely check for hazards such as cracks, inadequate windrows, unstable material on the slope below the tip head, or a loaded-out slope. Any unsafe conditions should be reported immediately, with operations suspended if required. If defects are found during an inspection, they must be recorded in writing, reported to the operations manager if urgent action is needed, and the relevant operator must ensure that a written record of the defect and action taken are kept as part of the HSMS.

11.5 Tip maintenance and inspection

Regular maintenance of tip surfaces should be undertaken, as well as the access and exit routes. This helps to make sure vehicle hazards due to spillage, wheel ruts, potholes and water ponding are minimised. Windrows or backstops should be maintained in height and profile.

Control dust using water trucks or spray systems to reduce dust nuisance and poor visibility hazards. Dust control in dumping areas should be at least equal to that in loading areas.

When completing inspections look for indications of inherent failure mechanisms or defects due to poor operational practices.

These can include:

TENSION CRACKS OR SETTLEMENT

A tension crack or settled area near the edge of a tip or stockpile is a warning sign of an unstable, or marginally stable, slope. Cracking is an indicator that some movement has already taken place. If movement has occurred, then the slope material is unable to support its own weight, and it should not be relied on to support additional weight, such as a truck.

If there is a tension crack in the dump area, vehicles should not travel over or near the crack. The additional weight of the vehicles may trigger the slope to fail. Loads should be dumped a minimum of one truck-length away from the crack or in an alternative area.

Cracked areas should be clearly marked and isolated so the area is not used, or the condition should be immediately corrected by flattening that area of the tip. This can be done by dumping material at the bottom as a buttress, and carefully pushing material down from the top using a track-dozer.

Tension cracks will tend to run parallel to the edge of the slope. In some materials, other types of surface cracking may occur as a result of the material drying out. Drying cracks tend to be randomly oriented.

MOVEMENT OF SLOPE MATERIAL

A crack or a scarp (a steepened area where the material has slid) on the slope is an indication of instability. Bulging of the slope material is not always as apparent as cracks, but it is another sign the slope material is moving.

Bulging can be detected by looking along the slope of the tip, especially the area near the toe, and paying particular attention to any material that is not at the normal angle of repose.

Bulging of the ground next to the tip is an indication the foundation underneath the tip is too weak to support the weight of the tip. A failure through the foundation could cause a portion of the tip to slide.

Where any signs or movement of bulging material is recognised, dumping operations should be immediately stopped. Dumping operations may resume after a risk assessment and consequent control measures (including re-forming the tip) have been completed and actioned.

SOFT AREAS

Ruts and accumulations of water may indicate soft areas. The hazard in this situation is that as a truck starts to dump, the tyres may sink into the soft area. In the worst case this could result in the truck tipping over, especially if combined with material hanging up in the tray.

Soft areas should either be clearly marked so the area is not used, or the condition should be immediately corrected by re-grading and sloping the area to promote better drainage.

Drivers should stop dumping and move to a firmer area if they feel the tyres sinking into the ground and immediately report such occurrences to their supervisor.

INADEQUATE WINDROWS

Inspections should include checking windrows are adequate to prevent vehicles getting too close to the edge. Windrows must be designed, constructed, installed and of sufficient height to offer definite restraint in the event a vehicle accidentally collides with them.

It is important vehicles do not reverse forcibly into a windrow. As the tyres sink into the windrow, the heavy loading on the rear tyres gets closer to the edge, which can cause the edge to give way. Inspections should include checking for tyre marks on the windrow material. If you notice tyre marks, the potential hazard of this practice should be discussed with drivers immediately and appropriate action taken.

For more information on construction of windrows, see Section 8.3.

UNDERMINED SLOPES

When material is loaded out from the toe of a slope, it makes the slope less stable and more prone to sliding. In this weakened condition the material at the edge of the slope may not be able to support its own weight and the additional weight of a truck. An undermined slope is especially hazardous at a tip head because the additional weight of the truck, if positioned too close to the edge, can cause the edge to suddenly give way.

Because of this hazard, even without cracks or other signs of instability, dumping at or near the edge, where the tip has been loaded-out and undermined, should be strictly prohibited. If your examination identifies an undermined area, it should be cordoned off and rectified.

11.6 Other considerations for stockpiles

Walls or other supports provided to contain stockpiles should be designed by a competent engineer to ensure their stability. If stockpiles grow to an extent that was not anticipated, they should be subject to a design review to ensure safety. In windy conditions, spray water on the stockpiles to minimise the dust hazard.

Engulfment

Engulfment can occur where loaders (or other mobile plant) are removing material from a stockpile that is substantially higher than the loading equipment. Hazard control measures (benching, height restrictions, and continuously collapsing the face so it does not overhang) and emergency procedures (in the case of an engulfment) should be established.

Where using draw down points, such as reclaims, there is a risk mobile plant will fall or inadvertently drive into a draw down hole. Major contributing factors include:

- the suitability of mobile plant for the stockpile design and operating environment (for example mobile plant operating alongside relatively steep stockpiles with heights above the safe limits of mobile plant)
- the operator not being aware of the location of draw down points and either driving into the hole, or sliding into the hole
- the operator driving over the top of a bridged hole that suddenly collapses
- insufficient surface structures or other navigational aids that could be used by the operator to identify the location of draw down points.

Where there is a risk of engulfment, mobile plant should be designed to protect the operator and provide for prompt recovery of the operator. Consideration should be given to the rescue of people in the event of an emergency. Recovery systems and methods should be developed and tested.

Control measures for engulfment at draw down points

The stockpile mobile plant should be designed to withstand engulfment forces of at least 40psi (280kpa). This assumes a safety factor of 2:1 and is based on USA stockpile dozer incidents and investigations.

Devices, such as flags or lights, to assist the mobile plant operator in determining whether draw points are operating.

Pedestrians should be prohibited from the hazardous area at all times, for example draw down points.

Provide communication devices, such as radio telephones and mobile phones, so mobile plant operators can communicate with the control room in the event of an emergency.

Safety equipment should ensure the operator is in a safe atmospheric environment if the mobile plant cab is engulfed to help with rescue. Equipment includes breathing apparatus, rescue harness, emergency lighting and mats or portable bridges (to bridge the gap between stable ground and the engulfed mobile plant).

Position indicating devices should be used to assist mobile plant operators in determining the location of draw down points in high-risk zones. Audible or visual alarms should be provided to alert the mobile plant operator. Devices you could use include GPS, cameras over draw down points, proximity detection and fixed structures to provide a reference point.

11.7 Reworking or reshaping tips

Tips may be re-worked or re-shaped for landscaping or for operational requirements (for example, forming roads over dumped material). A geotechnical specialist should be consulted when planning rehabilitation to ensure the stability of the tip at all times. For more information on rehabilitating tips, see Section 7.6.

12.0

Extraction in and around water

IN THIS SECTION:

- 12.1 Planning and design
- 12.2 Excavation procedures
- 12.3 Extracting beneath water
- 12.4 Floating plant and boats

Working in and around water poses additional risks to extraction.

This section describes how to:

- excavate safely under water
- safely access floating plant.

12.1 Planning and design

Before any excavation, a competent person should assess the ground conditions to determine all factors likely to affect the stability of the ground and the limitations that should be imposed on the excavation design. See Section 6 for details on planning safe excavations.

This assessment should be documented, so it can be reviewed and revised when a material change has occurred in the ground conditions or the excavation methods. Effective ground control relies on geotechnical information obtained at different stages of the life of the site – during planning and design, at implementation of the design and through day-to-day operations.

There may be a relative lack of data available during the initial planning and design. It is essential to consolidate information gathered during operations with information in the geotechnical model and to continually assess the suitability of the design in relation to ground stability.

If your site is using a dredge or floating plant, consider whether it is a principal hazard (for example, if multiple people could be on the dredge, there could be a risk of an incident resulting in multiple deaths). If it is determined to be a principal hazard, then there must be a principal hazard management plan (PHMP). It may be more suitable to manage the use of the dredge or floating plant via a PHMP to have all the risk control measures managed in one place. Where practicable, consider remote control operation of dredges to eliminate the risk of people drowning.

12.2 Excavation procedures

Excavation procedures rules should be drawn up, setting out:

- how excavation activities should be carried out, specifying the type and reach of excavators
- the physical dimensions of the excavation, including slope, depth, height of free faces, width of benches, and position of windrows
- how material should be removed from the excavation
- restricted access to the edge of the waterline
- the nature and frequency of supervision
- response to defects.

12.3 Extracting beneath water

Excavations should be kept stable even if you cannot see them. When extracting beneath water, slopes will be saturated.

Draglines, clam shells and long-reach hydraulic excavators may over-steepen the slope they stand on and cause failure. These slopes should be treated as a significant hazard. Working methods should be based on the geotechnical assessment of the material being excavated, allowing for any variation of submerged materials.

The working bench should be kept flat and clear of equipment or material to enable a rapid exit in the event of instability of the face. The front edge of the bench should always remain visible to the operator. Tracks of surface equipment should face the excavation, or be no more than a 45° angle, with track motors facing away from the face (see Figures 56 to 58).

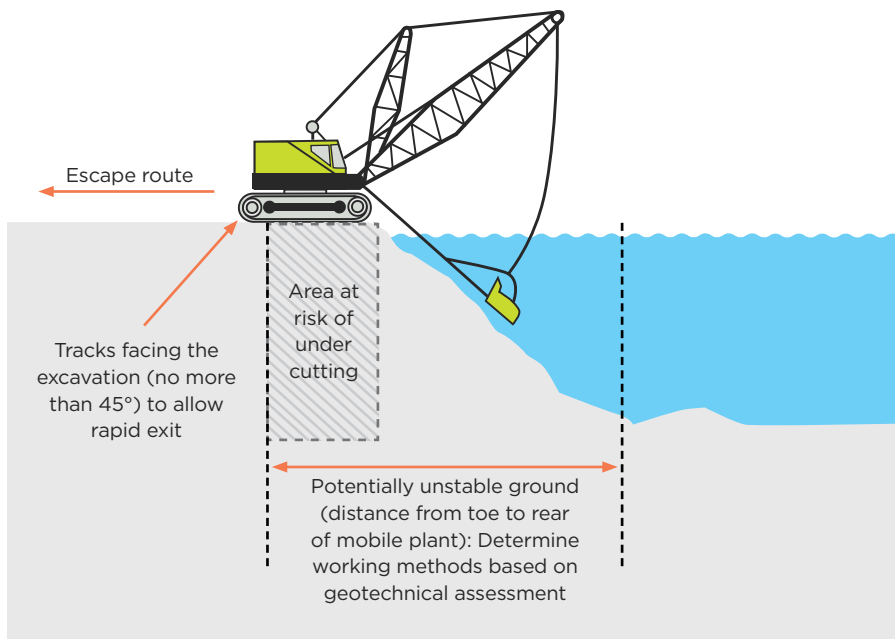

FIGURE 56:
Dragline working beneath water

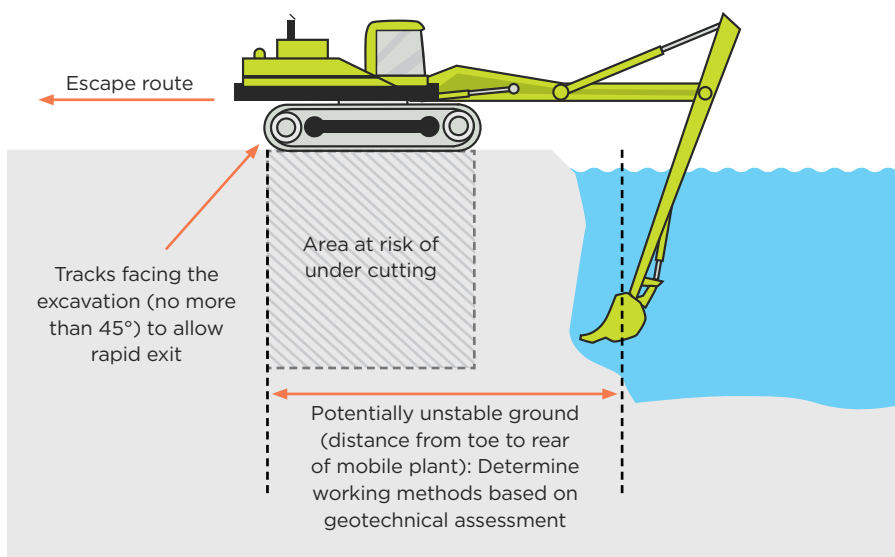

FIGURE 57:
Long reach excavator working beneath water

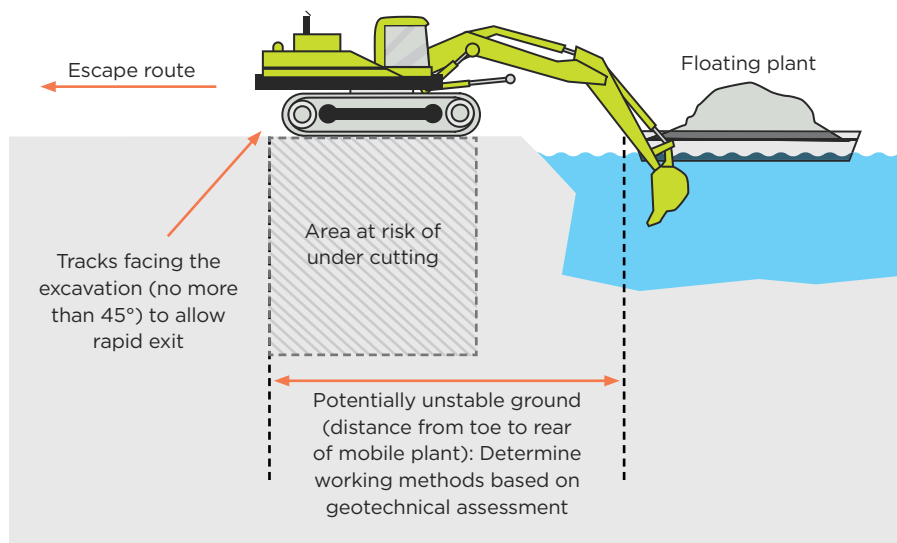

FIGURE 58:
Excavator working
beneath water,
loading floating plant

Edge protection, barriers, warning signs and other suitable control measures should be placed around any water filled excavation to keep people away from any hazardous zones and to stop mobile plant driving into the water. Edge protection, barriers or signs should be moved as the excavation progresses and the hazardous area changes. Means of rescuing trapped or injured people must be provided (see Section 3).

If there is any doubt about the safety of excavations, operations should be stopped and remedial control measures undertaken.

When loading floating plant, there should be clear signals or communication between the excavator operator and the floating plant operator so feeding can stop if required. Where trommel screens are used, a visual or audible warning device should be used to alert the excavator operator if the trommel has stalled. Such an occurrence can cause the screen to become overloaded and could compromise the stability of the floating plant if loading continues.

Emergency procedures must be in place. This may include equipping mobile plant with features or tools for use in an emergency, such as push-out windows or window breaking tools.

12.4 Floating plant and boats

Floating plant or boats (including those used on settling ponds) may be governed by the requirements set out in the New Zealand Maritime Transport Act 1994 and Maritime Rules. Nothing in this section precludes you from complying with the requirements of the Maritime Transport Act 1994 or Maritime Rules where it applies to your vessel. Maritime New Zealand is the national marine safety regulator.

Floating plant should be designed, manufactured and maintained to the required standard, to ensure the floating plant will:

- not become unstable due to shifting loads or being overloaded
- remain stable while being towed
- remain waterworthy in operating conditions.

Floating plant and vessels should have periodical structural checks done by an engineer or a surveyor.

As a general guide, you will need the documents outlined in Table 11 to legally operate your floating plant or boat (hereafter referred to as a vessel):

VESSEL TYPE	SAFETY SYSTEM	MARITIME RULES RELATING TO DESIGN, CONSTRUCTION AND EQUIPMENT
Floating structures that are not navigable, that is they are permanently attached to the shore (for example, floating jetties, gangways)	No maritime documentation	Not covered by the Maritime Transport Act or Maritime Rules. Covered by the Building Act 2004
Barges over 24m in length	Barge Safety Certificate	Part 40C Part 41 may apply Part 42A Part 42B Part 46 Section 3 Part 47 Section 3 Part 49 (where there are lifting appliances)
Barges less than 24m in length	If the barge carries people on board during a voyage, Maritime Operator Safety System (MOSS) applies	Part 40C (Appendix C on stability rules)
Barges less than 24m in length that do not: - have a lifting device with a working load limit (WLL) of 1 or more tonnes or - carry passengers (does not include crew) - carry cargo	No maritime documentation	Part 40C (Appendix C on stability rules)
All powered vessels	Maritime Operator Safety System (MOSS), if the vessel is used commercially	The vessel will need to be surveyed by a Maritime NZ recognised surveyor for compliance against all applicable maritime rules

TABLE 11: Maritime rules

For more information on the Maritime Transport Act 1994, Maritime Rules and maritime safety systems contact Maritime New Zealand or visit maritimenz.govt.nz

Safe means of access and egress

Safe means of access (for example, a gangway) should be provided to vessels, floating processing platforms, draw off points or submersible pumps where people have to access them for work purposes (see Figure 59).

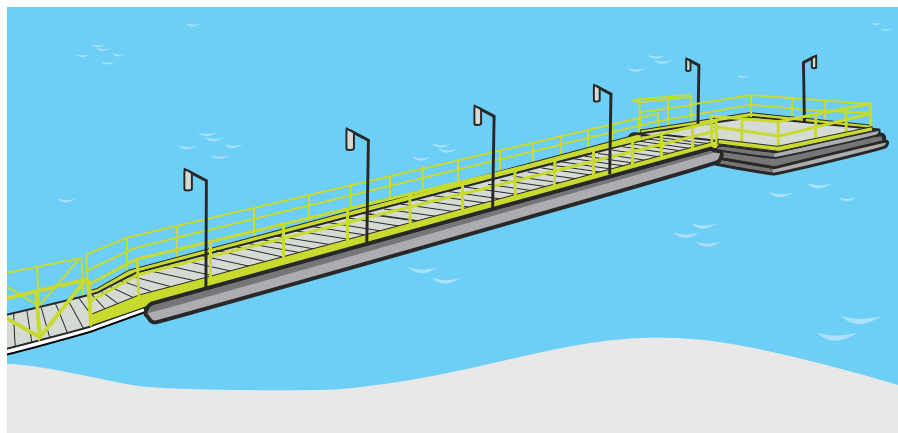

FIGURE 59:
Example of gangway

Where using jetties, gangways, platforms, bridges or walkways they should be fitted with suitable handrails or other means to stop people falling in the water (see Figure 60).

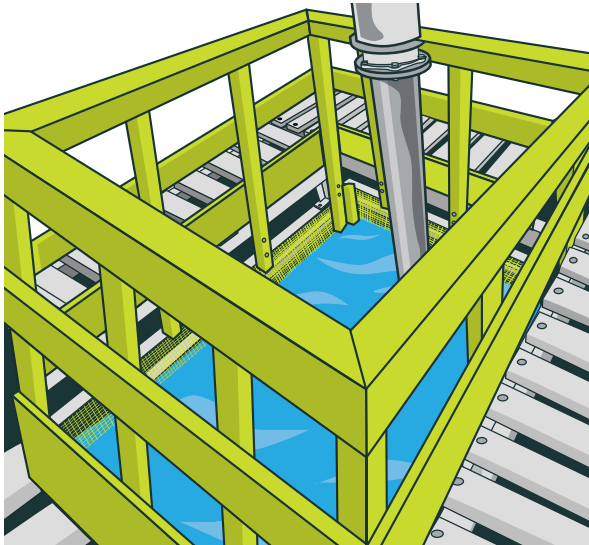

FIGURE 60:
Example of guardrails
around a water
pick-up station

Separate the cables and pipes or store them away from walkways to avoid tripping (for example, in cable trays). Surfaces of walkways should be slip-resistant.

Sufficient lighting should be provided if jetties, gangways, platforms, bridges, walkways, stairs or ladders might be accessed when it is dark.

Where ponds and floating processing plants are used in alluvial mining, take precautions at the edge of the excavation. While emphasis should be on the stability of large excavators and unstable ground conditions, precautions should also include pedestrians accessing floating platforms from the excavation edge.

A person should not be lifted in plant, if the plant is not specifically designed to lift or suspend a person. Excavator buckets should never be used to transfer people to floating screens or plants. Do a risk assessment to identify a reasonably practicable method of access. For example, using a drawbridge or moving the floating platform to the shore (see Figure 61).

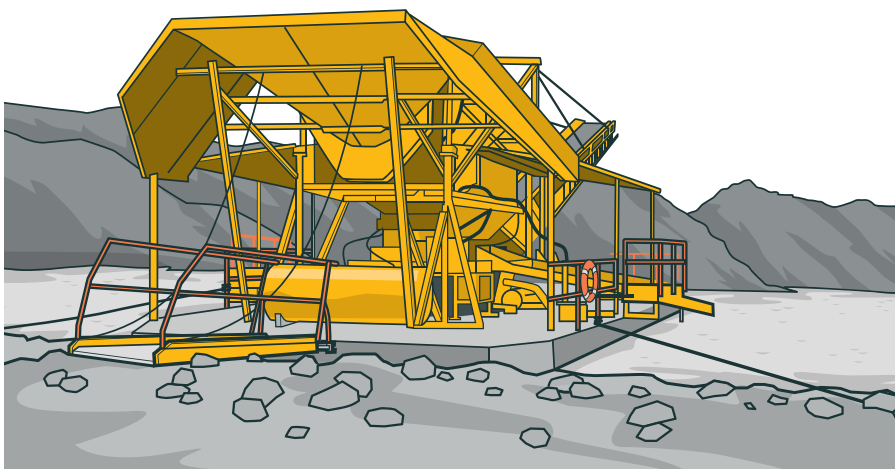

FIGURE 61:
Floating plant
with drawbridge

Where reasonably practicable, avoid having people on board floating plant while it is fed by an excavator.

Consider providing remotely operated rope winch systems and power wash systems during the design stage (safety by design). This eliminates hazards associated with workers making frequent visits to floating processing platforms.

For more information on construction and installation of platforms, walkways, stairways and ladders refer to *Clause D1 Access Routes* of the New Zealand Building Code, or see the [Building Performance website](#) at the Ministry for Business, Innovation and Employment (MBIE).

Design and modifications to vessels

You should not submerge dredge or floating plant decks under any circumstances. If the freeboard of a dredge or floating plant appears to be insufficient, a competent person should be engaged to evaluate and rectify the buoyancy. Make sure dredge or floating plant decks do not become submerged under any operating conditions. This is particularly important when sludge builds up on the cutter head and when the cutter is driven into the bottom of the pond or into a working face during mining operations.

Equipment installed on the dredge or floating plant should be secure so that it will not shift and destabilise the dredge or floating plant.

Where trommel screens are used, an automatic tripping device or warning should be installed to stop the trommel screen if the tailings discharge belt stalls. This can cause the screen to get overloaded and affect the stability of the plant.

Modifications can cause vessels to capsize due to additional weight or the effects modifications can have on the balance of the vessel. Establish procedures to ensure modifications to the original design do not exceed the design capacity set by the manufacturer.

Procedures should also consider examination and maintenance of safety control measures provided by the manufacturer to make sure modifications to the original design do not reduce the in-process weight safety margin. For example, ensure dredge overload and full hopper alarm switches are functioning within the specifications of the manufacturer to maintain freeboard levels.

For more information on barge stability, see Maritime New Zealand Barge Stability Guidelines.

Repairs and maintenance of vessels

To ensure the integrity of vessels, you should establish maintenance and repair programmes. These may include:

- regularly checking decks and hulls for cracks and holes
- sealing all covers over hatches in the deck with continuous excess marine sealant to ensure water tightness
- regularly checking all hull compartment bulkheads are watertight to isolate water flow if water ingress occurs in any individual compartment
- providing a sounding tube for each hull compartment that extends to near the bottom of the compartment so the compartments can be sounded daily for water ingress.
- procedures to make sure repairs are undertaken in pontoon cells when leaks develop
- regularly checking ropes and rigging for signs of wear.

Dredges should also have an adequate capacity pump with a non-collapsible suction pipe long enough to reach the bottom of any hull compartment. When water ingress is detected, the water can be quickly and efficiently removed from the hull before the buoyancy of the dredge is seriously affected.

The use of polyurethane or polystyrene in hull compartments does not ensure buoyancy of dredges. These materials are not recommended because they deteriorate over time, becoming porous and water absorbent, and they do not allow for regular inspection of the hull compartment surfaces.

Hull compartments are confined spaces, so use a confined space working procedure. Refer to the standard *AS 2865 Confined Spaces* for more information on confined space entry. For more information, see our guide for [Confined spaces: planning entry and working safely in a confined space](#)

For more information on repairs and maintenance, see Section 15.15 of this guide.

Boats

Boats, like any other equipment, should be of adequate size and power to properly perform the anticipated task. Weight capacity includes people, motor, equipment and any other haul load. If you are using a boat to retrieve an item, then the weight of the item should be taken into consideration when assessing if the boat is suitable for the retrieval task.

Boats must be operated by workers who comply with any licensing and certification requirements, and who have adequate experience or training, or who are supervised by a competent person.

For licensing and certification relating to boats, contact [Maritime New Zealand](#)

Commercial vessels will need to be entered into the Maritime Operator Safety System (MOSS). For more information on MOSS, contact [Maritime New Zealand](#)

Ropes, pulleys, winches and rigging

All navigable floating plant will require mooring. This is usually accomplished with winches and ropes.

On smaller plants with manual winches and rope, the main hazard is tripping. Larger plants may have substantial winches and large diameter wire ropes. These present additional hazards from gear failure (ropes or pulleys breaking) and whiplash as strain is exerted on rigging. One control measure is to establish exclusion zones.

Ropes, pulleys and other rigging should be covered or otherwise protected. Workers should stand well clear of any hazardous zones when the ropes are taking strain. For more detailed information on load lines see Part 47 of the Maritime Rules.

Anchoring should be firmly positioned and not prone to undermining.

The use of galvanised ropes is advisable to prevent the unseen, internal corrosion that can occur in steel wire ropes operating constantly in and around water. Regardless of the rope used, all associated equipment such as pulleys, rope clamps and sheaves should be specified based on the rope diameter and safe working load. A routine rope condition inspection procedure should be used.

Personal flotation devices

The terms personal flotation device (PFD), lifejacket, life vest, life preserver, buoyancy vest and buoyancy aid are used interchangeably, all with the same key purpose: to prevent people drowning. A PFD is a garment designed to keep a conscious person afloat and to assist with buoyancy in the water.

Generally, Type 401 open waters lifejackets are the most appropriate lifejackets for a working environment, as they are designed to keep an unconscious person face up in the water. Some are manually activated with a pull-cord and others will automatically inflate when submerged in water ('hydrostatic').

Check that your lifejackets are marked as meeting an approved standard. They should meet *NZS 5823:2005 - Specification for buoyancy aids and marine safety harnesses and lines*, or another national standard (such as Australian) that is at least equivalent or better.

Establish and enforce policies for wearing PFDs. Like seatbelts in vehicles, PFDs are effective only when they are worn. The PCBU should do a risk assessment and select the most appropriate PFD for use at the operation.

All workers working on or next to water should wear a PFD. Take into account the personal protective equipment (PPE) and equipment a worker will have on their person when considering PFDs. Subject to the operational conditions and remoteness of workers (including emergency response time), consider using PFDs with integrated safety systems that include an automated man overboard alert system if the unit becomes immersed.

Provide sufficient quality PFDs of the proper type appropriate for each worker's weight. Inspect and maintain the PFDs in serviceable condition and replace them if they become worn or damaged. Make sure all relevant personnel are trained in the use of PFDs. Consider keeping spare PFDs on site for replacement of damaged units and for visitors.

PFDs may be supported by buoys and rescue lines (ropes) for emergency response, but should not be seen as a replacement for a PFD.

Emergency exits

Cabins should have an emergency exit in the event of a sinking or capsize, such as a push-out window or a trapdoor. The emergency exit should be large enough to allow a person to pass through wearing their PFD.

Fire systems

Dredges and vessels with enclosed engine rooms should have a means of detection and alert in the event of excess heat, smoke or fire. There are various integrated systems that are commercially available and should be powered by battery and not from a generator or mains power.

Fire detection systems and fire-fighting equipment are subject to various requirements for testing, inspection and record-keeping under the Maritime Rules.

Workers should also be trained in what to do in the event of a fire on board the dredge or vessel.

13.0

Water or tailings storage in ponds and dams

IN THIS SECTION:

- 13.1 Inspecting for signs of failure
- 13.2 Technical operational review
- 13.3 Cleaning out ponds and dams

Instability or failure of ponds and tailing dams can cause harm. Design, construct, operate and maintain ponds and tailing dams appropriately to prevent this harm.

This section describes how to:

- inspect ponds and dams, and identify potential causes of failure
- review ponds and dams periodically
- maintain ponds and dams.

The responsible person for an operation must take all practicable steps to eliminate, isolate or minimise hazards associated with ponds and dams. Safe systems of work should identify and control any risks to workers and anyone else who may be affected by activities associated with ponds and dams (including nearby landowners). This includes workers who need access to potentially hazardous areas for purposes such as carrying out inspections and cleaning out ponds or dams.

The responsible person must make sure a competent person examines ponds where workers are, or will be, before the start of each working shift and at suitable times during the shift. This practice should also be applied to dams.

If a principal hazard management plan (PHMP) for tips, ponds and voids at a mining operation requires regular inspections to be carried out, then the PHMP must specify how often inspections occur. Every accessible area of dams or ponds, including areas with barriers, should be inspected by a competent person at least once a week.

For more information on PHMPs, planning and design criteria, geotechnical assessments and construction of ponds and dams see Section 7.

13.1 Inspecting for signs of failure

Once a dam or pond has been constructed, regular monitoring (including routine visual inspections) and maintenance should be carried out to minimise the risk of failure.

The most common failures for a typical small earth dam or pond are surface erosion from overtopping, internal erosion (such as piping or seepage) and embankment slumping. These failures can arise from defects such as inadequate spillways, uncontrolled seepage, design and construction deficiencies, and a lack of maintenance.

If any of the following signs of distress or other unusual characteristics develop, take immediate action to ensure safety, and engage a technical expert to investigate, to make sure the dam or pond is safe and compliant with all necessary regulations.

Upstream slope

Inspect the upstream slope of an earth dam or pond for any signs of erosion, beaching or slumping. These may be caused by wave action, flooding, or a rapid drop in the water level.

A damaged upstream slope reduces the stability of the dam by limiting its ability to resist wave action and high water levels. Failure of the upstream slope can result from undercutting, erosion, depressions, and other signs of a possible slip or landslide.

Crest

Inspect the crest of a dam or pond for shape and cracks. A variation in levels across the top of the dam or pond may indicate abnormal settlement (vertical downward movement) or an underlying void and internal erosion that could cause the eventual failure of the dam or pond.

Dewatering and overflow channels

Check dewatering channels for weed growth and side collapses. Safety issues include edge collapse while inspecting, silt build-up in the channel, and vegetation hiding undermined edges.

Overflows can be decanting pipes, angled pipes, spillways or armoured channels. Inspect these regularly, particularly after substantial rainfall.

Check for blocked intakes of decant, or angled pipes clogged with vegetation or other debris. A significant hazard when clearing blocked intakes is the sudden release of water into the pipe, which can suck someone into the intake, causing injury or drowning. Blockages should only be cleared with machinery or tools that keep people away from the intake.

Clear partially blocked overflow channels quickly and safely. Put in place remedial measures to limit the amount of floating vegetation. Make sure armoured channels are not scoured when there is high water flow, as this can erode the crest and affect the stability of the embankment.

Downstream slope

Inspect for seepage when the water is at or near its highest level. Examine the downstream slope, downstream toe, abutments, and areas near spillways or outlets.

Seepage can be indicated by wet spots or muddy areas that are usually accompanied by the lush growth of tussock and other grasses. The use of piezometers will help you to detect seepage early and should be considered as a control measure. You may need to get specialist advice from a competent person about the type of piezometer to use and where to place them.

Small amounts of steady seepage (not concentrated flows) are not usually a serious concern, as long as there is controlled drainage and ponding does not occur. An area of known seepage that suddenly stops or significantly decreases may indicate an area of distress and should be investigated.

13.2 Technical operational review

A competent person should undertake regular technical operational reviews to make sure the dam or pond is operating as intended and meeting all regulatory requirements.

Technical operational reviews should:

- check that previous review recommendations have been actioned
- confirm appropriate responses have been given to any incidents or issues
- verify compliance with specifications (for example, inspection, monitoring and quality control) and regulatory requirements
- validate the continued use of the dam or pond design
- recommend any necessary operational or design modifications.

The type and level of information provided in the technical operational review should be consistent with your risk assessment for dams and ponds.

Keep a record of review outcomes indicating recommended actions and details of how issues were addressed or solutions implemented. Seek specialist advice from a competent person if necessary.

If the tip or pond is a dam under the Building Act 2004 and requires a dam safety assurance programme (DSAP) under the dam safety scheme, the DSAP will also include requirements for inspection and review of the dam. For more information on DSAPs and requirements, see the [Building Performance website](#)

13.3 Cleaning out ponds and dams

The main risks when cleaning out ponds and dams are created by undercutting and making the embankment unstable (particularly under water), or by mobile plant driving on too soft ground that cannot support the plant's weight.

Settling ponds can be deceptive, as they can form a crust which appears stable but the silt beneath remains soft. Mobile plant should be kept back from the edge by at least a distance of 1.5 times the height of the face (see Figure 62).

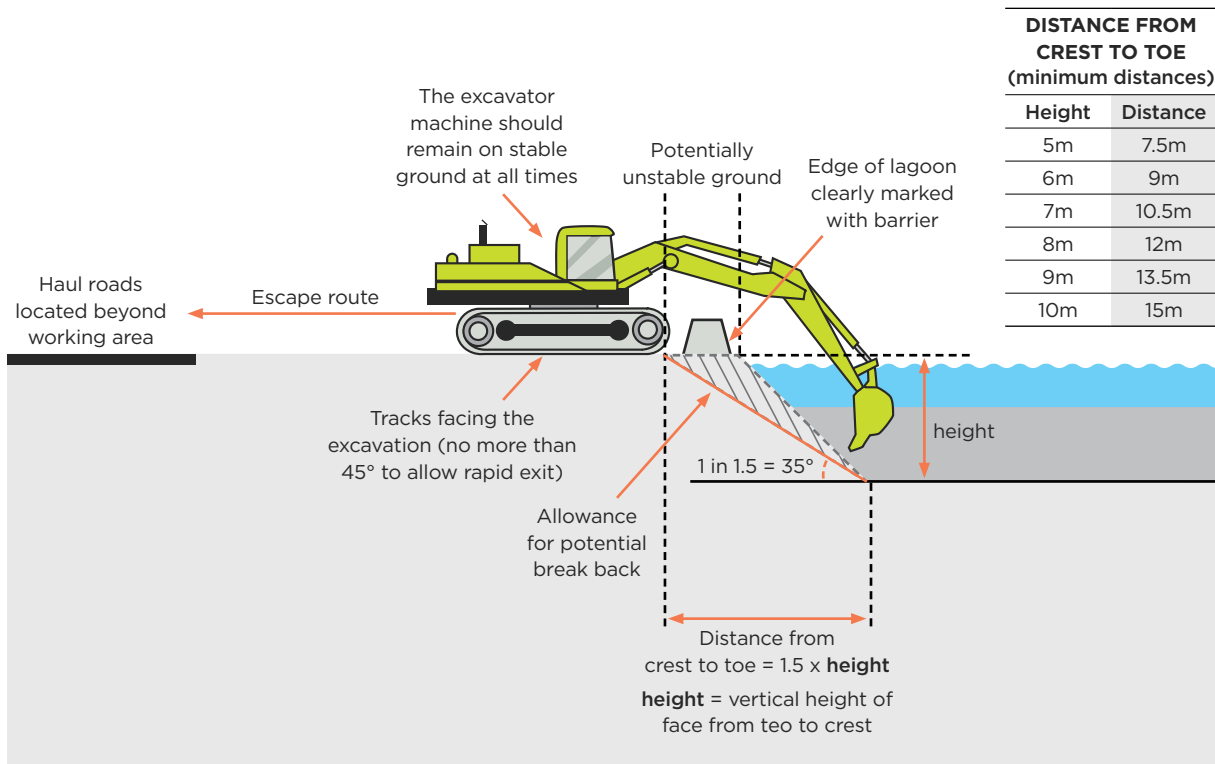

FIGURE 62: Example of cleaning out a settling pond with an excavator

Removing silt

Carry out a risk assessment to identify the appropriate methodology and plant to use to remove silt. The most common way is to use an excavator. Other methods include using dredges, suction pumps or vacuum pumps.

Operators using mobile plant, such as an excavator, should constantly monitor the crest for signs of slumping, cracking or instability. If there are signs of instability, all work should stop, workers and plant should be removed, and access to the area prohibited. Seek geotechnical advice if necessary.

The mobile plant operator should only remove silt as planned, and not excavate the pond or dam's retaining structure. The edge of the silt pond should always be clearly marked, ideally by barriers such as a bund.

The mobile plant should be as far from the lagoon edge as operationally possible, and should be capable of obtaining the necessary depth of dig while maintaining this distance. The mobile plant's tracks should be perpendicular (at a right angle) to the pond edge, so a safe, rapid exit from the area can be made if the slope suddenly becomes unstable.

The excavated silt should be removed as far from the crest of the pond or dam as possible to prevent loading of the crest, causing it to fail. Make sure any removed silt does not block the safe exit route of the mobile plant.

If excavated silt is loaded directly into a truck, the type of vehicle used should be risk assessed to ensure it is fit for purpose. Consider the type and moisture content of material being loaded, and the load shifting in the tray of the vehicle.

When not in use, all mobile plant should be parked safely away from the water's edge.

14.0

Vehicles and traffic management

IN THIS SECTION:

- 14.1 Public safety
- 14.2 Site access: contractors, visitors and public
- 14.3 Overhead power lines
- 14.4 Other overhead structures
- 14.5 Reversing, manoeuvring and parking
- 14.6 Loading vehicles
- 14.7 Loading and storage of large stone slabs or blocks
- 14.8 Feeding crushers
- 14.9 Railway sidings
- 14.10 Safe drivers and vehicles
- 14.11 Inspecting and servicing vehicles
- 14.12 Tyre safety
- 14.13 Maintenance and repair of roads

Any vehicle movement can pose significant risks at extractives sites, because of the size of the vehicles used and the environment people are working in.

This section describes traffic management measures for:

- site safety and safe vehicle practices
- moving around hazards
- keeping safe speeds, distances and manoeuvres
- using safe and appropriately trained drivers
- selecting and maintaining suitable vehicles.

See also Section 8 for details on planning for roads and vehicle operating areas. For more in-depth information about safe practices for vehicles and mobile plant at work sites, see our good practice guidelines for [Managing work site traffic](#) as well as quick guides on [Seatbelts](#) and on [Safe reversing and spotting practices](#)

There are several ways vehicle activities can be a risk to workers at an extractives site. These include:

- the failure of a roadway (a collapse or slip)
- interactions between vehicles and pedestrians, vehicles and structures, or between two or more vehicles (vehicles carrying passengers, light and heavy vehicle interactions)
- the loss of vehicle control (the driver falling asleep or driver impairment, mechanical failure, loss of traction or tip over)
- the extent of hazards on the roadway such as sharp corners, steep inclines, drop-offs or traffic volume
- other hazards involving vehicles (fire, explosion, falls from height, tyre hazards or visitor vehicles).

In the design, layout, operation, construction and maintenance of every road within the extractives operation, you must give adequate consideration to:

- the grade and width of the road
- the drainage system
- mobile plant characteristics, including operator visibility, stopping distances and manoeuvrability
- operating speeds, driver position and remote-controlled mobile plant
- the characteristics of light and heavy vehicles to be used and their interaction.

You should also consider:

- the effect on road conditions caused by expected environmental conditions during operating periods (including time of day, weather, temperature and visibility)
- the impact of road design and characteristics, including gradients, width, camber, surface and radius of curves and intersections
- the impact of mine design, including banks, windrow design and steep drops adjacent to vehicle operating areas
- the volume and speed of traffic and the potential for interactions between mobile plant with different operating characteristics, including heavy and light vehicles
- the potential for interactions between mobile plant and pedestrians, including consideration of park up areas and driver access
- the potential for interaction between mobile plant and public traffic
- the potential for interaction between mobile plant and fixed structures, including overhead and underground power lines, tunnel walls and roofs.

14.1 Public safety

Consider the ways work on the site may create a risk not only to workers, but also to the public.

From a health and safety perspective it is good practice to divert public rights of way around mines or quarries. Where it is not possible, precautions should be implemented, based on a detailed risk assessment of the route and the area around the site. The precautions should be reviewed regularly.

Access to sites should be controlled to make sure unauthorised people cannot travel to a location where they may be at risk from site operations. This is particularly important for sites where there are sales to the public or in residential areas. Control measures may include signage, automated barrier arms or worker-controlled areas (for example, a weighbridge operator).

Providing and maintaining suitable barriers around the site to discourage trespass may be appropriate. Trespass means entry to the site without express or implied permission. Barriers are appropriate where it is reasonably foreseeable that members of the public, including children, are likely to trespass on the site, and could suffer injury if they did so.

The type of barrier required depends on the risks. In a rural area, where risk of public access is low, hedges trenches and mounds may be enough. In areas where there is evidence of persistent trespass, which places the public at significant risk, substantial fences may be needed.

Workers should be encouraged to report cases of trespass or evidence that people have been on the site. They should also be told what action to take if they discover trespassers.

Signage

Suitable signs warning people of the possible hazards at the site should be erected at entry points and, where necessary, along boundaries. Any signs should be maintained in a legible condition.

Examples of signs warning of hazards and prohibited zones are shown in Figures 63 to 65.



FIGURE 63: Examples of signage warning of hazards



FIGURE 64: Example of signage for small sites



FIGURE 65: Example of sign at gate

14.2 Site access: contractors, visitors and public

On entering the site, vehicles and pedestrians should be directed to a safe area, unless instructed otherwise. This is usually achieved by signage, but may include road marking, footpaths or barriers. Allow sufficient parking spaces for workers and visitors.

Where site vehicles cross a footpath or turn from or onto a public road, consider public safety. This may involve discussions with the local council or New Zealand Transport Agency Waka Kotahi (NZTA) as part of the planning process.

Contractors and visiting drivers

Carefully consider contractors and visiting drivers, who may need to access operational areas. Assess their needs and induct them to ensure they are aware of the site rules and procedures and what is expected of them. Take steps to determine whether the visitor is competent to operate a vehicle at an extractives site.

For example, light vehicles (such as maintenance vans) invariably need to attend heavy vehicle breakdowns in operational areas. If possible, the heavy vehicle should be taken to a dedicated service area for the contractor to work away from operational areas. Give the visiting driver the traffic management plan, or escort them so their movements and operations are strictly controlled.

Regardless of the size of the site you should establish safe systems of work, which could include vehicle visibility (see Section 14.10), induction systems and signage as required.

Consider fully inducting regular visitors such as inspectors, contractors, couriers and delivery workers, so that they understand the hazards on site. All visitors should be escorted if not fully inducted to the site.

See also Appendix E for more information of overlapping duties.

Pedestrian separation

Pedestrian activity in operational areas should be restricted, wherever reasonably practicable, especially when it is dark. Workers should not enter operational areas as a pedestrian unless authorised to do so.

Pedestrians should use separate routes wherever practicable, for example pedestrian-only areas and safe, designated pedestrian routes (see Figure 66). Other control measures may include using light vehicles to transport workers to their place of work, or only allowing pedestrians to enter areas when vehicles are stationary (such as lunch breaks). Where separation by time is used as a control, check pedestrians have moved out of the area before operations begin again.

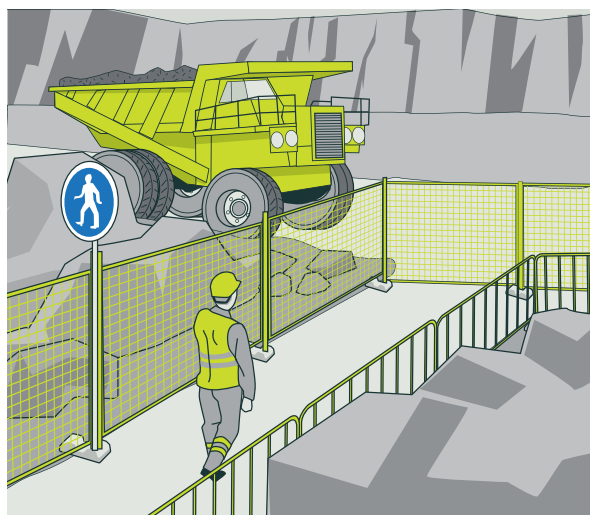

FIGURE 66:
Example of
pedestrian route

For smaller sites, or where only a few people are working, holding areas may be appropriate. For example, signage stating visitors are to remain at the site hut until authorised to proceed.

Often heavy vehicles park near workshops or staff rooms, so the interaction of pedestrians should be carefully managed by designated walkways and separation barriers.

14.3 Overhead power lines

Overhead power lines on a site are likely to pose a significant risk unless they are sufficiently high enough so that vehicles and equipment cannot approach or contact them. Vehicles do not need to strike the overhead lines for injury to occur – electricity can arc a significant distance depending on the voltage and conditions, so maintaining clearance distances is very important.

The most effective way to prevent harm from contact with overhead lines is by not carrying out work where there is a risk of vehicles making contact with or closely approaching the power lines. Roads should be routed to avoid them. If there is a risk, and the road or working area is permanent (or long-term), consult its owner to find out if the line can be permanently diverted away from the work area or replaced with underground cables.

The standard *AS/NZS 3007:2013 Electrical equipment in mines and quarries – Surface installations and associated processing plant* has further information to inform the risk assessment relating to power lines.

If it is not practicable to eliminate this risk, minimise the risk as far as reasonably practicable. When there is a possibility that a vehicle could reach the danger zone around the cables, use precautions such as those illustrated in Figure 67. During the risk assessment, consider the possibility of vehicles travelling with a raised tray. A risk assessment is required to enable the development of the electrical engineering plan. Overhead power lines will be a part of that plan as well as roads and other vehicle operating areas.

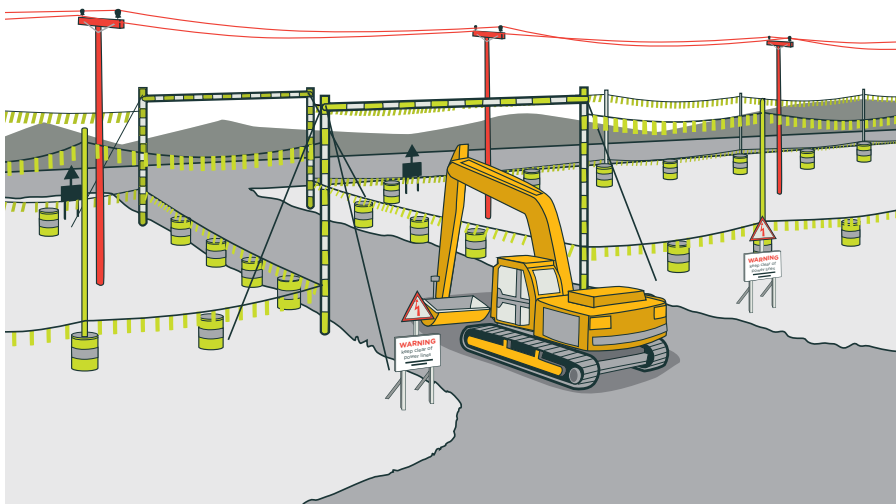

FIGURE 67:
Safe working under
overhead power lines

Approach distances vary with the voltage of the power line. It is best to have a blanket single distance for your extraction site. For circuit voltages up to 110kV an accepted distance is no closer than 4m to the overhead power line. For circuit voltages above 110kV the minimum safe approach distance is 6m. For more information on approach distances see the [New Zealand Electrical Code of Practice for Electrical Safe Distances \(NZECP 34\)](#).

Where vehicles or mobile plant are likely to be used near overhead power lines, a permanent sign should be installed in a visible place as near as practicable to the driver's position. The sign should be maintained in a legible condition and must state 'Warning: Keep clear of power lines' and include the distance to, and the voltage of, the power lines. For mobile crushers or transportable conveyors, the sign should be installed in a clearly visible place at each towing point and adjacent to driving controls.

If work needs to be carried out below power lines and it is possible that vehicles could reach into the danger zone, the lines should be isolated and earthed before work begins. If this is not practicable, physical safeguards such as chains on the booms of excavators may be required to prevent vehicles reaching into the danger area. Written consent is required from the line owner before any work is carried out.

If the operation changes the type of vehicle normally used, or a contractor's vehicle is brought onto site, a risk assessment should be carried out to determine if contact with conductors is a potential risk.

Emergency procedures should outline what to do in the event of contact with an overhead power line (see Section 3). The procedure should include the operator not exiting the plant and the vehicle being isolated, to manage the potential risk of electrocution or tyre explosion in the procedures. Most power line asset owners have information available on their websites for working around overhead and underground power lines. One example is available from Vector at [Safety near our networks](#)

14.4 Other overhead structures

Measure and record the vertical clearance under overhead obstructions on routes. Take into account any underhanging lighting, ventilation or other service features, which are often added after the initial design. Routes used by vehicles should allow for sufficient overhead clearance. Vehicle routes should also avoid anything that might catch on or dislodge a load.

Protect any overhead obstructions (such as electric cables, pipes, conveyors or walkways) using goalposts, height gauge posts or barriers.

Give clear warnings of any limited width or headroom in advance and at the obstruction itself such as signs or audio warnings. Position these warnings at a sufficient distance from the structure so any vehicles can stop in sufficient time if they are oversize (see Figure 68). For more information about signs see Section 14.1.

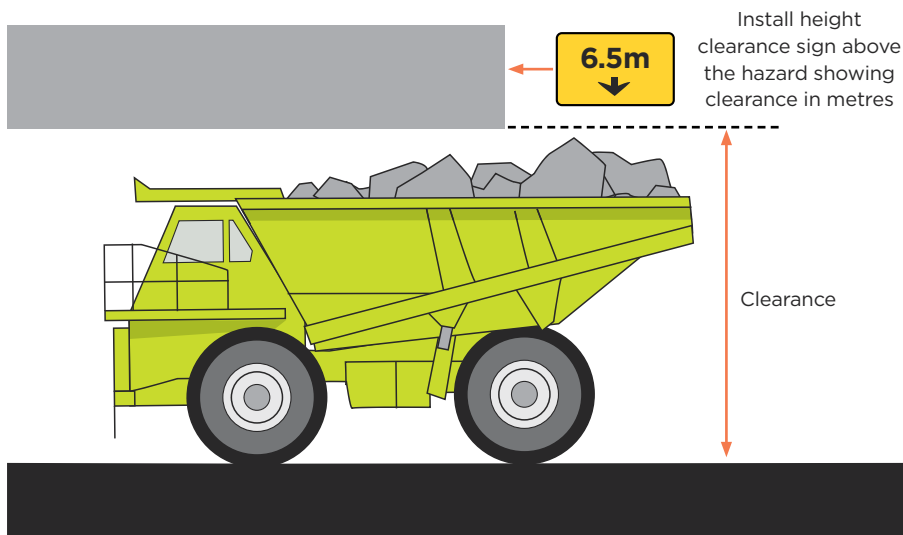

FIGURE 68:
Example clearance signage and placement

14.5 Reversing, manoeuvring and parking

Reversing is hazardous because the driver has reduced visibility and is in an awkward driving position.

The most effective way of reducing reversing incidents is to use one-way systems and turning bays. Where this is not practicable, organise sites to keep reversing to a minimum. Where reversing is necessary, you should consider:

- ensuring adequate visibility for the driver
- installing engineering control measures (collision avoidance equipment)
- installing reversing cameras, proximity detection equipment and reversing alarms (see Section 14.10)
- providing safe systems of work
- providing adequate supervision and training.

Where safe reversing relies on reversing aids (such as reversing cameras) the vehicle should not be used if they are defective. Temporary control measures could be used to ensure safety (for example, using a spotter).

When it is dark, site lighting and vehicle lights should provide sufficient light for the driver to see clearly when reversing.

No single safeguard is likely to be sufficient on its own during reversing. Consider all the relevant precautions together (see Table 12).

TYPE OF CONTROL MEASURES	EXAMPLES OF CONTROL MEASURES
Eliminate need to reverse	<ul style="list-style-type: none"> - Implement one-way systems around site and in loading and unloading areas - Provide designated turning areas
Engineering control measures	<ul style="list-style-type: none"> - Fit collision avoidance equipment that warns the operator of the presence of a pedestrian, object or another vehicle and stops the vehicle from operating - Fit proximity devices to warn the driver of possible collision with an object or person
Reduce reversing operations	<ul style="list-style-type: none"> - Reduce the number of vehicle movements as far as possible - Instruct drivers not to reverse, unless absolutely necessary
Adequate visibility	<ul style="list-style-type: none"> - Fit reversing cameras, radar, convex mirrors and so on to overcome restrictions to visibility from the driver's seat, particularly at the sides and rear of vehicles
Make sure safe systems of work are followed	<ul style="list-style-type: none"> - Design vehicle reversing areas which: <ul style="list-style-type: none"> - allow adequate space for vehicles to manoeuvre safely - exclude pedestrians - are clearly signed - have suitable physical stops to warn drivers they have reached the limit of the safe reversing area - Make sure everyone on site understands the vehicle rules - Fit all vehicles on site with appropriate warning devices such as reversing alarms - Have controlled (or supervised) reversing systems such as the excavator operator controlling the truck coming in to be loaded - Use spotters - Check that procedures work in practice and are actually being followed

TABLE 12: Control measures for reversing options

Spotters

A spotter's (or signaller's) job is to guide drivers and make sure reversing areas are free of pedestrians or other hazards.

If you are using spotters, make sure:

- only trained spotters are used
- they are clearly visible to drivers at all times
- a clear and recognised system of communication is adopted
- they stand in a safe position throughout the reversing operation.

The PCBU must establish a safe system of work so anyone leaving a vehicle does not enter a hazardous area. This includes when operators are undertaking daily start-up inspections and shift changes.

Following distances

If a vehicle follows another vehicle too closely, an accident can occur if the driver in the trailing vehicle does not react as fast as the lead driver, or if the trailing vehicle cannot stop as effectively as the lead vehicle. You should have a safe system of work for vehicles following one another at a safe distance.

There are many factors that contribute to the necessary following distance. As vehicle speeds increase, the following distance should be lengthened to provide the necessary level of safety. Drivers should increase their following distance in conditions where visibility is reduced (such as fog), or when road conditions may result in a longer stopping distance (like those in wet weather).

Consider the speeds on both level roads and gradients, and establish following distance rules that provide for safe distances in all situations, with loaded and unloaded vehicles.

The established following distance rules should be kept in the site Traffic Management Plan or the Roads and Other Vehicle Operating Areas PHMP.

Visual aids can be used to determine following distances (for example, spacing road marker pegs at the site's following distance rule).

Stopping distances

Three key factors determine the minimum stopping distance a vehicle requires:

1. the distance travelled during the operator's reaction time
2. the distance travelled during brake response time
3. the distance the vehicle travels before coming to a stop.

Quite often the Original Equipment Manufacturer (OEM) will only specify braking distance as specified in factor 3.

The minimum stopping distance can be calculated by adding the above three factors together. Gradients and wet conditions will also have a significant effect on factor 3, and they should always be factored into the calculations provided in OEM braking data.

The load on a vehicle, traction, and how the brakes have been applied (soft, medium, hard) also affect the stopping distance of a vehicle.

In areas where excessive stopping distances are calculated, speed restrictions may be required to make sure the final calculated stopping distance meets acceptable operational requirements.

Parking

Vehicles should be parked on level ground wherever practicable to eliminate the possibility of the vehicle inadvertently being set in motion. If it is not practicable to park a vehicle on level ground, prevent the vehicle from accidentally moving by making sure the wheels are secured, chocked, blocked, angled against a suitable bund, or parked with wheels in a purpose-built contour.

Develop a safe system of work for leaving a vehicle unattended. For example, requiring drivers to switch off the engine, remove the ignition key, and apply all brakes. For mobile plant this may include lowering ground engaging equipment (excavator buckets, dozer blades, ripper teeth and scraper bowls) to the ground. Vehicles should never be parked in the swing radius of an excavator or the manoeuvring zone of other operational vehicles, unless in accordance with a safe system of work.

When it is necessary to park light vehicles close to heavy vehicles (for example, for maintenance purposes) the heavy vehicle should be parked before the light vehicle enters the area. The heavy vehicle should remain immobilised throughout the operation. The light vehicle should be parked in an area that is either inaccessible to the heavy vehicle or in a position where the heavy vehicle operator can see the light vehicle.

Site operators should ensure vehicles are only operated by competent people unless adequately supervised. Mine and quarry operators must ensure mobile plant is only operated by competent people, who are authorised in writing. This may mean ensuring keys, or any other devices for starting vehicles or mobile plant, are in a secure place while parked.

You should establish a safe system of work so anyone leaving a vehicle does not enter a hazardous area. This includes when operators are undertaking daily start-up inspections and shift changes.

Access and egress to heavy vehicle working areas

For access to heavy vehicle working areas, use walkways wherever practicable. Walkways should be made of slip-resistant grating (with enough space for mud or oil to pass through the grate and away from the walkway surface) or another slip-resistant material.

To prevent thrown mud from making them slippery, position walkways, steps, ladders and handrails away from wheels if possible.

Top and middle guard rails may be needed to protect people when they are standing or crouching. Consider collapsible rails.

Vehicle owners should consider fitting guardrails if they are not already present (see Figure 69). If features are retrofitted to existing vehicles, the alterations should not affect the structural integrity of the vehicle or the visibility of the operator.

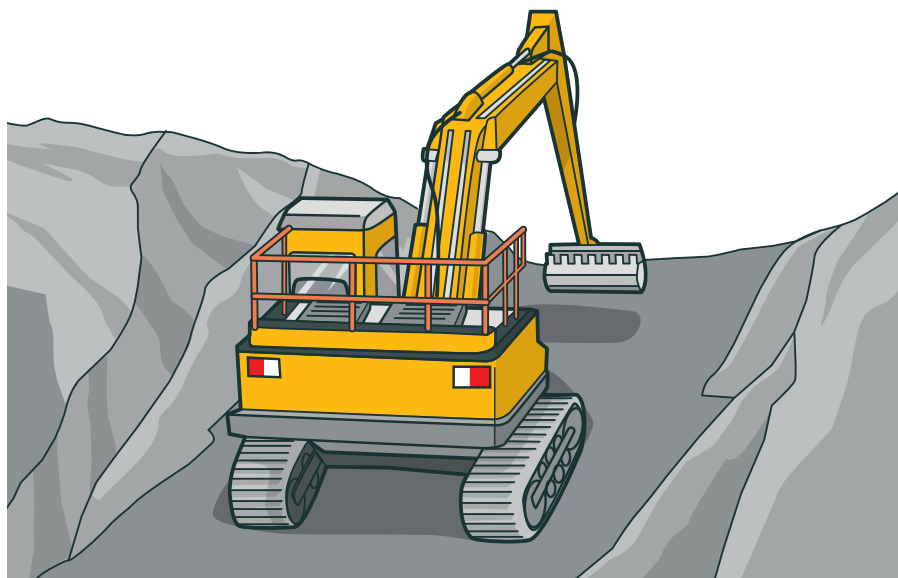

FIGURE 69:
Excavator with fitted guardrails to protect workers accessing the top of the machine for maintenance purposes

Climbing on or off vehicles

Access to heavy vehicles should be by a well-constructed ladder or steps. Ladders or steps should be well built, properly maintained and securely fixed. Where steps or ladders extend to the ground, the use of interlock systems is required to prevent the vehicle moving or starting until the ladder or step has been correctly stowed.

Avoid using suspended steps wherever practicable. If they cannot be avoided, use rubber or cable suspension ladders, not ladders made of chains. Ladders and steps should slope inward towards the top if this is reasonably practicable. They should not slope outwards towards the top.

Rungs or steps on vehicles should:

- be level and comfortable to use
- have a slip-resistant surface
- not allow mud, grease or oil to build up dangerously (grating could be used to allow things to pass through a step).

The first rung or step should be close enough to the ground to be easily reached – ideally about 40cm and never more than 70cm. Place ladders or steps as close as possible to the part of the vehicle requiring access.

Opening (and holding open) a cab door on a vehicle should not force a driver to break the ‘three-point hold’ rule or to move to an unsafe position.

Vehicle owners should consider retrofitting safer access ways to eliminate the risk of falling (see Figure 70 and Figure 71).

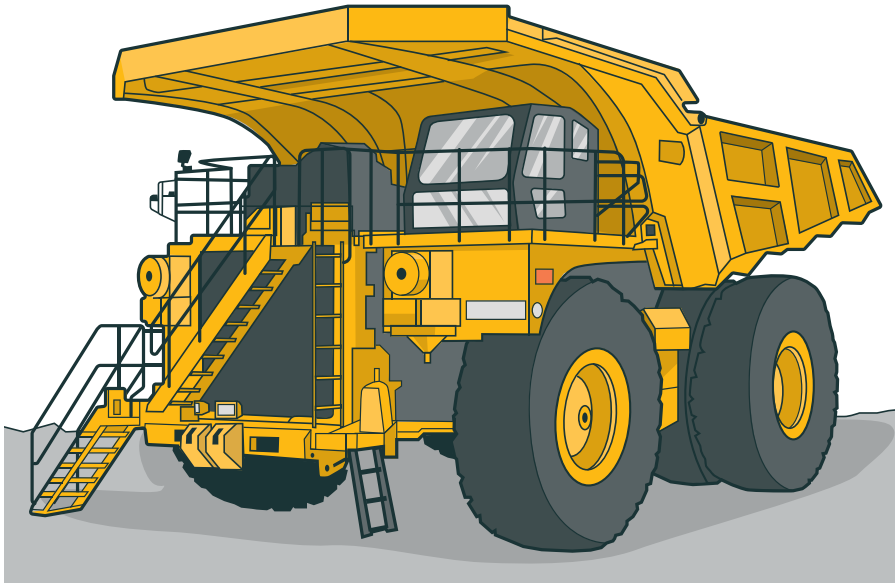

FIGURE 70:
Haul truck with retrofitted stairway and platform to increase driver access and egress safety

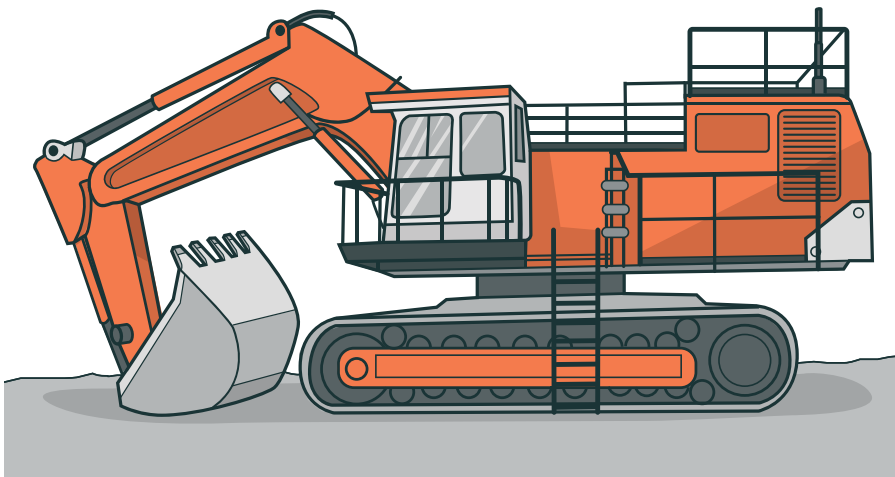

FIGURE 71:
This excavator has a good access system, with platforms, guardrails, kick plates and ladder – the ladder is interlocked so the vehicle cannot be started without the ladder being raised

14.6 Loading vehicles

Loading, for the purposes of this section, refers to the loading of vehicles with excavated material by mobile plant. For information on safety when loading mobile plant or equipment (or other loads) from transporters or trucks, see The Truck Loading Code. For information on loading floating plant, see Section 12.3 and 12.4.

Depending on the nature of the site, loading may be into haul trucks, truck and trailer units, utility vehicles or car trailers (for example, where selling of product is directly to the public).

Loading zones

It is recommended that the loading zone (or prohibited zone) be a minimum of 6m around the truck, trailer or mobile plant. This zone may need to be larger, depending on the visibility of vehicles or traffic movement associated with loading (see Figure 72).

In addition to the loading zone, restricted zones should be established based on a site-specific risk assessment, which considers the movement of vehicles associated with loading.

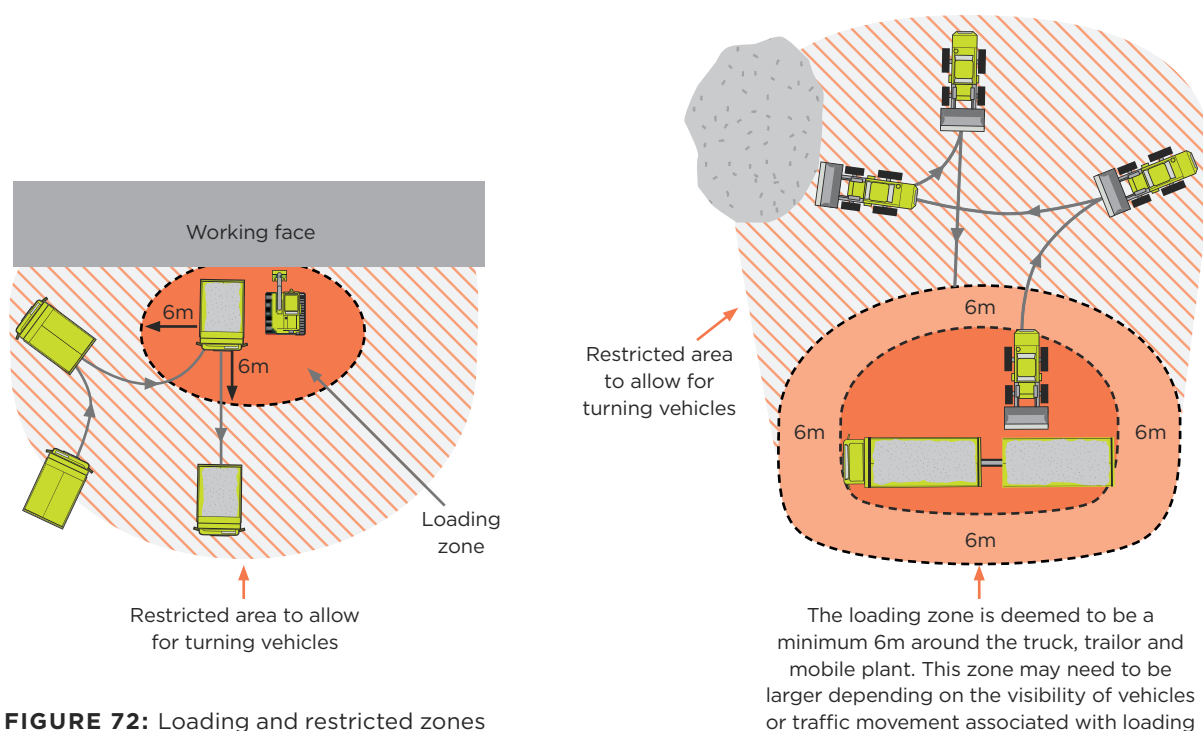

FIGURE 72: Loading and restricted zones

The entry of any vehicle (other than those being loaded) or pedestrians into a loading zone while excavation and loading operations are active should be prohibited.

Determine a safe system of work which specifies communication protocols for vehicles entering the loading zone (to be loaded). For example, the system could specify contact is made with the mobile plant operator to request permission to proceed. On larger sites this may be coordinated by a supervisor or other designated person in control of traffic movements.

The safe system of work should also specify steps to be taken, including the immediate suspension of works, if a vehicle or pedestrian enters the loading zone without prior permission.

Loading operations

PCBUs must identify hazards and, where eliminating risks is not reasonably practicable, minimise those risks through control measures. Insecure loads and overloaded vehicles can present a significant hazard whether on a public road or a road within the confines of the site.

The Land Transport Act 1998 contains the load security legislation for vehicles driven on public roads. It provides strict liability for offences involving insecure loads and loads falling from vehicles. The Truck Loading Code details the general requirements that must be met to ensure a load cannot fall, and it applies to the operator or any person loading the vehicle.

Refer to the original equipment manufacturers loading instructions and weight limit recommendations.

Loads must be secured and remain safe while loading, while the vehicle is being driven, and during unloading. When loading or unloading, the vehicle should be level, stable and stationary. Apply all vehicle and trailer brakes, and follow these principles:

LIGHT VEHICLES

- Spread loads as evenly as possible during loading. Unbalanced loads can make the vehicle or trailer unstable, or overload individual axles.
- Prohibit loading over cabs unless the driver is out of the vehicle and away from the loading zone (in a safe area).
- Avoid loading to the back of the trailer as this can cause the trailer to tip backwards (especially for single-axle trailers). This can reduce the grip the vehicle has on the road surface, as the wheels are lifted away from the ground.
- Balance loads across the axle (or axles) of a drawbar so coupling or uncoupling can be managed easily and safely, and the trailer is stable when being transported.
- Wherever possible couple (or uncouple) drawbar trailers unloaded, as this makes them easier to handle and generally safer to work with.
- Select suitable mobile plant or purpose-built devices (hoppers) that reduce the risks to other vehicles or pedestrians.

ON-ROAD VEHICLES

- Spread loads as evenly as possible during loading, based on advice from the driver, and do not load over cabs. Unbalanced loads can make the vehicle or trailer unstable, or overload individual axles (see Figure 73).
- All drivers (and where applicable, passengers) should remain in the vehicle during loading.
- If the load is to be covered, an on-vehicle covering device that can be worked from ground level or a safe place higher up should be provided. Alternatively, a load covering platform or gantry should be used.
- As loose loads normally rely on the vehicle body for restraint, it is extremely important to make sure all body-to-chassis attachment points ('U' bolts, hinge pins, hinge pin brackets and so on) are secure, and the attachment points and body are in sound condition.
- Doors to bulk bins must be closed to avoid loose bulk loads from being blown out.
- When travelling on a public road, loose bulk loads should be covered whenever there is a risk of load shedding due to wind action or movement. Body work should be kept in good condition to minimise hazards during transportation. This applies particularly to badly fitted tail gates that permit gravel and stones to fall to the roadway. Loose bulk loads being transported in a vehicle on a public road without a tarpaulin fitted, should at no time reach higher than 100mm below any side of the vehicle (see Figure 74).
- Body height extensions (hungry boards) should only be used where conditions and type of load permit. In these circumstances, supports should be adequately fixed to the existing body. It is not adequate to rely on the load within the parent body of the vehicle for support. Where necessary, tie-chains should be used transversely at the top of body extensions to prevent sideways spread.

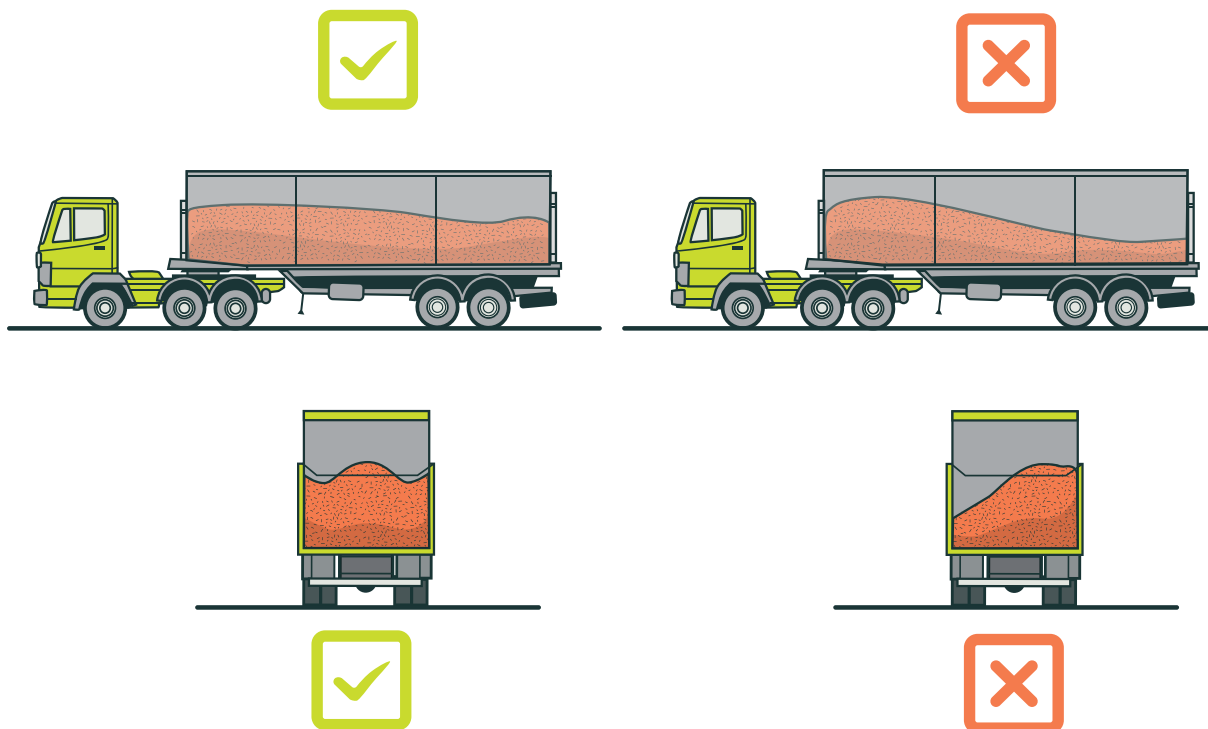

FIGURE 73: Loads should be spread evenly across the vehicle

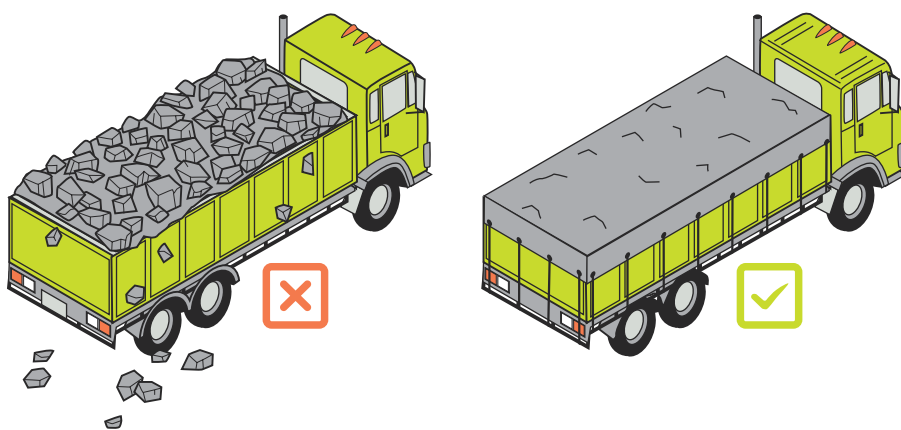

FIGURE 74: Cover loose bulk loads when travelling on a public road

OFF-ROAD VEHICLES

- Spread loads as evenly as possible during loading. Unbalanced loads can make the vehicle or trailer unstable, or overload individual axles.
- Prohibit loading over the cabs.
- All drivers (and where applicable, passengers) should remain in the vehicle during loading.
- Loads should not be dropped from height to avoid people in the cab being thrown around or injured.
- If particularly large rocks are being loaded, placing a fine material bed will provide some cushioning and stability.
- The placement of loads should ensure they are secure.
- The excavator or loader should be matched to the size of the truck being loaded.

Covering loads

Loads should be covered whenever there is a risk of load shedding due to wind action or movement when travelling on a public road, in line with The Truck Loading Code – specialised requirements (loose bulk loads).

Covering loads or removing covers can be hazardous, especially when carried out manually. Consider the risks associated with load covering and take effective measures to make sure covering and uncovering loads is done as safely as possible. Consider the types of loads and vehicle, how often covering or uncovering happens, and take other specific characteristics of your workplace into account.

There are several options for covering loads, but some are better than others. A method of covering and uncovering that does not involve getting on to the vehicle or even touching the cover should be the first choice.

A hierarchy of control measures for load covering could involve this sequence of considerations:

1. Leaving the load uncovered if it is safe to do so.
2. Using automated or mechanical covering systems that do not require people to go up on the vehicle (see Figure 75).
3. Using manual covering systems which do not require people to go up on the vehicle (see Figure 76).
4. Using work platforms to provide safe access to carry out covering from the platform without having to access the load (see Figure 77).
5. Using gantry or harness systems to prevent or arrest a fall (see Figure 78).

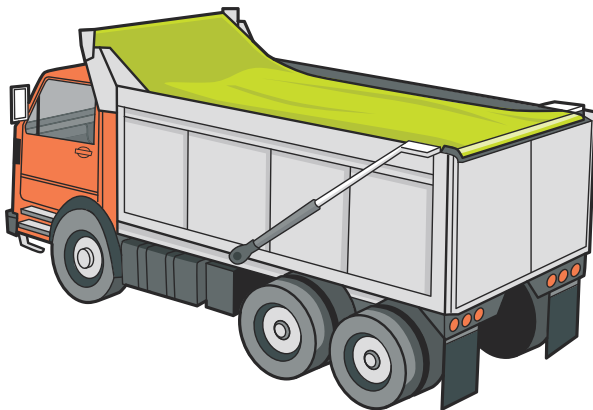

FIGURE 75:
Automated
covering system



FIGURE 76:
Manual covering system



FIGURE 77:
Platform covering system



FIGURE 78:
Overhead gantry harness system

Consider the following points regardless of which method of covering you use:

- Do not overload the vehicle and try to load evenly to avoid the need for trimming. Load evenly along the length of the vehicle (not in peaks) or use a loader to pat down the load to flatten peaks.
- Train and instruct staff on safe systems of work (and provide refresher training where necessary). Supervise and monitor covering and uncovering activities.
- Regularly check covers are in good condition and replaced when necessary. Visually check straps and ropes used for pulling and securing the cover.
- Regularly inspect, repair and maintain covering mechanisms, platforms, gantries and fall-arrest equipment (such as harnesses and lanyards).
- During loading, unloading and covering, consider vehicles used by workers of more than one company 'shared workplaces' and arrange for suitable control measures to be followed by everyone concerned.
- Ropes, straps and covers can snap or rip. The driver should avoid leaning backwards when pulling the cover tight.
- Park vehicles on level ground, with parking brakes on and the ignition key removed.
- Cover vehicles before leaving the site.

Whatever way it is done, carry out covering and uncovering in designated places, away from passing vehicles and pedestrians and, where possible, sheltered from strong winds and bad weather.

Weight limits

Maximum vehicle and axle weights must never be exceeded. Overloaded vehicles can become unstable and difficult to steer, or less able to brake.

Extractives operations with roads and other vehicle operating areas must include in their PHMP the maximum load that may be carried or towed by vehicles and equipment (whether by reference to weight, dimensions or other criteria) on their roads and other vehicle operating areas.

14.7 Loading and storage of large stone slabs or blocks

Transporting and storing large stone slabs or blocks carries a high risk of serious personal injury if not done safely. Depending on the type of rock, slabs or blocks can fail during handling in unpredictable ways. For example, natural stone can be fissured and may crack or shatter unexpectedly during handling. Due to their size and weight, such slabs or blocks are potentially unstable.

To ensure the safety of workers, you should determine a safe system of work that includes:

- prohibition zones - not allowing people into an area where a slab or block may fall during transport or lifting
- written work instructions (or standard operating instructions) - workers should be given appropriate information, instruction and training on the dangers of large stone slabs or blocks and the need to follow safe systems of work
- adequate supervision by a competent person
- always restraining slabs or blocks during loading or unloading operations (whether from vehicles or from storage). This should include attaching and detaching straps, lifting slings and so on. This is especially important when people may be in the hazardous area where a slab may fall during lifting, and when loading or unloading vehicles (due to the variable and sometimes unpredictable effects of road camber or vehicle suspension)
- using only appropriate loading equipment (such as forklifts and cranes) that are designed for the lifting requirement and are properly maintained and operated by competent personnel
- providing, maintaining, using and inspecting appropriate certified lifting equipment and PPE
- making sure loads are secured while being transported.

When using rack type storage systems, they should be designed and certified to prevent slabs toppling over or slipping out from the base. Traditional A-frame storage is not suitable in this context unless modifications have been made to achieve this goal.

14.8 Feeding crushers

If the crusher is to be fed directly by a loader, truck or excavator, then:

- standing pads should be suitable (stable) and high enough for the operator to monitor the feed hopper from the cab
- keep the ramp wide enough to allow for adequate edge protection on either side of the ramp as well as the travel of the vehicle when using wheeled loaders or trucks
- the maximum gradient of the ramp should be within the capability of the loading vehicle
- the last few metres of the ramp should be level, so the vehicle is not discharging uphill. This helps operators monitor the feed. The vehicle will also be more stable
- make sure pedestrians and obstructions are kept out of the excavator swing radius or loading area.

14.9 Railway sidings

Where raiiling sidings enter a site, you should:

- where practicable, have a means of locking siding entrances
- where practicable, have tracks separated from other operational areas
- have a safe system of work for communication about train arrival times and days (for example, having the rail operator advise of trains entering the site at least 24 hours prior)
- make sure tracks are not obstructed and are kept clear of debris
- where appropriate, put signage in place advising of train arrival and other hazards.

The siding is likely to require a rail licence under the Railways Act 2005 and related safety case requirements. Operators should contact NZTA for more information.

14.10 Safe drivers and vehicles

Drivers should be competent, or adequately supervised, to operate a vehicle safely and should receive appropriate information, instruction and training for the make and model of vehicles they use. It is particularly important that less experienced drivers are closely monitored following their training to make sure they work safely.

Protocols should be established to ensure drivers and passengers wear their seatbelts. Past accidents have shown that staying in the cab with the seatbelt fastened is the best way to avoid a serious injury or death when a vehicle loses control.

Training and competency of drivers

Drivers must be licenced to drive on a public road. The licence must be appropriate for the class of vehicle being driven. Periodically check that your drivers have current licences.

Where drivers are required to drive on roads within the mine site, employ systems and procedures for training and verifying the competency for people to drive on site. This verification of competency records should be kept on site as a part of the training records. Choose a driver training system that follows a recognised standard.

Training requirements will depend on an individual's experience and training they have previously received. Risk assessment should help decide the level and amount of training a person receives. In general, newly recruited drivers have the greatest training needs, but there should also be a reassessment programme for more experienced drivers. It is preferable that the person undertaking the assessments receives training to be an assessor.

It is important to assess information provided by newly appointed drivers, particularly in relation to training and experience. Monitor them on site to establish both their actual level of competence and any further training needs.

Keep a record of training and licences for each driver to help ensure the most appropriate person is allocated a particular task and identify those requiring refresher training.

Excavations operators must authorise mobile plant operators in writing. Authorisation to operate should be for every individual mobile plant.

Fitness to drive

A person's fitness to drive a vehicle should be judged on an individual basis, but the aim is to match the task requirements with the fitness and abilities of the driver.

Pre-employment health assessments and on-going health assessments should include assessment and monitoring that relates to a person's ability to safely drive a vehicle (and undertake any associated tasks).

Site health control measures may require random alcohol and drug testing. For detailed advice on medical standards of fitness to drive, see the NZTA website.

Vehicle suitability

Vehicles should be suitable for the type of work being done and the place they are being used. Selecting suitable vehicles can reduce or eliminate many risks at the site. It is generally much easier and cheaper to start with the right vehicle than to modify it later. Before purchasing a vehicle, you should at a minimum consider:

- the effectiveness of the braking system, bearing in mind the slopes it is expected to work on
- adequate visibility in all directions for the driver
- stability under all foreseeable operating conditions
- protection for the driver and any passengers from falling objects (falling object protective structure (FOPS)), overturning (roll-over protective structure (ROPS)) and seatbelts. Further information is available in the [Approved Code of Practice for Operator Protective Structures on Self-propelled Mobile Mechanical Plant](#)
- safe access and egress to and from the cab and other areas of the vehicle where access may be required
- adequate fall from heights protection when getting in and out of the cab, as well as around working areas at elevated heights (such as engine bays)
- engine firewall and fire suppression equipment
- lights, windscreen wipers, horns and other warning devices
- guarding for dangerous parts during use or maintenance work
- protection for the driver and any passengers from rain, high and low temperatures, noise, dust and vibration
- suitable seating for the driver and any passengers
- maximum loads that may be carried or towed.

Where vehicles are not fitted with safety features, consider retrofitting where your hazard identification and risk assessment process has recognised a significant hazard (for example, fitting reversing cameras). Consider emerging technology as part of the risk assessment control measures, such as safe approach signals, laser delineation systems, birds-eye 360° camera views and collision avoidance systems. Data acquisition systems that measure factors such as loading, speed, tip angles or braking are good management tools to assess driver behaviour.

For vehicles expected to enter sites when it is dark (whether or not work is scheduled to take place) additional supplementary lighting should be provided (such as forward and rearward facing spotlights) or additional vehicle-mounted work lights.

Any permanently fitted lights must comply with the Land Transport Rule: Vehicle Lighting 2004 when being driven on public roads.

Driver visibility

Many vehicles have substantial blind spots, not only immediately behind the vehicle, but also alongside and immediately in front of it. When you introduce a vehicle to the site, complete a risk assessment to identify the blind spots. Improving visibility requires a combination of approaches such as reversing cameras, collision avoidance systems, proximity sensors and mirrors.

Studies suggest that when used appropriately (such as drivers glancing at the collision avoidance system at appropriate moments) reversing cameras can successfully mitigate the occurrence of reversing crashes, particularly when paired with an appropriate audible warning system.

Accidents can occur when vehicles drive off or turn while a pedestrian or vehicle is passing or parked in a blind spot. As a guide, the driver should be able to see a 1m high object 1m away from any point within a vehicle. The driver should be able to detect the presence of other vehicles and pedestrians in their intended line of travel.

There should be a procedure to be followed before a vehicle drives off, for example:

- moving from being parked overnight or otherwise not in use - a single beep from the horn with a five second delay before driving off
- moving from an operational area - two beeps from the horn, with a five second delay before driving forward
- moving in reverse - three beeps from the horn with a five second delay before reversing.

A CLEAR VIEW

Drivers should not place items in the windscreen or in the way of mirrors or monitors, where they might impede visibility from the driving position. The area of the windscreen that is kept clear by the wipers should not be obscured, nor should the side windows. Windows and mirrors should be kept clean and in good repair. Dirt or cracks can make windows or mirrors less effective. If necessary, fit additional side-mounted mirrors to increase the driver's visibility (see Figure 79).

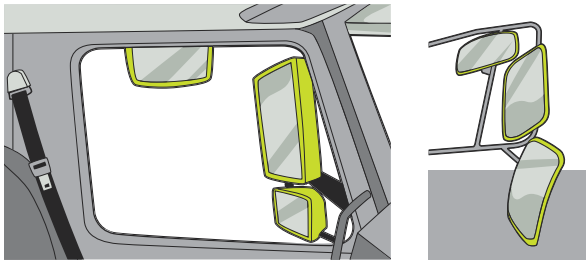

FIGURE 79:
Side-mounted mirrors

REVERSING ALARMS

Reversing alarms warn anyone in the vicinity that the vehicle is in reverse gear. They still rely on the driver having a clear view and the pedestrian or other vehicles moving out of the way.

Reversing alarms may be drowned out by other noise, or may be so common on a busy site that people do not take any notice of them. Using reversing alarms may be appropriate (based on your risk assessment), but will likely be most effective when used with other measures. Alarms can have different warning tones to meet environmental compliance requirements and still be effective in the intended zone of influence.

COLLISION AVOIDANCE AND PROXIMITY DETECTION EQUIPMENT

Collision avoidance equipment warns the driver of fixed obstacles or other vehicles along the route and stops the vehicle from colliding. Collision avoidance systems usually use GPS or local area wireless technology (Wi-Fi or Bluetooth) to determine vehicle position, speed and heading. Vehicle locations and paths are calculated and sent by radio link to all other outfitted vehicles in the area. Where two or more vehicles may collide, audible and visual warnings are sent to the drivers.

Proximity detection equipment warns the driver of the presence of people or objects in the immediate vicinity. Some proximity detection equipment is also able to stop a vehicle if it predicts a collision with a person, but drivers should always act to stop the vehicle from collision.

CLOSED-CIRCUIT TELEVISION

CCTV cameras can be mounted on the front, side and rear of a vehicle. Images are relayed to a screen located inside the cabin (see Figure 80). Some cameras are equipped with infrared illuminators, so the driver has a comprehensive view even when it is dark. Birds-eye view systems are now available that provide the operator with a 360° view of the vehicle from above. Forward facing and driver facing cameras record actions if sudden braking occurs.

Thermal imaging systems are also available and may be suited to sites where night operations are a concern.



FIGURE 80:
CCTV monitor
in vehicle cabin

Visibility of light vehicles

Light vehicles are at risk of being crushed by heavy vehicles. They should be kept away from areas where heavy vehicles operate.

Where this is not practicable, they should be fitted with rotating or flashing beacons, high visibility 'buggy whip' flags, high visibility and reflective markings or other appropriate measures. This makes them readily visible to drivers of other vehicles. The use of vehicle hazard lights alone is not deemed adequate.

For light vehicles expected to enter areas where heavy vehicles are operating, consider the following control measures during your risk assessment:

- Establish exclusion zones around heavy vehicles.
- Heavy vehicles should remain stationary when light vehicles are within exclusion zones.
- The impact on environmental conditions on visibility (for example, darkness, fog or rain).
- Fit vehicles with rotating or flashing orange warning lights, visible 360° from the vehicle, unless multiple lights are fitted to cover blind spots and fit with reflective strips.
- Fit radios so drivers can communicate with site supervisors or directly to heavy vehicle drivers.
- Develop a positive response communication protocol to ensure the heavy and light vehicle operators are clear about vehicle movement. This typically involves deciding on a signal to request and receive an approval to move the vehicle.
- Fit a warning flag (buggy whip flag) which can be seen by the operator of the tallest vehicle.
- Fit clearly visible numbering, or an alternative form of positive identification, as an aid for two-way communication between heavy vehicle and light vehicle drivers.

Light vehicle visibility control measures should apply to all light vehicles (for example, contractor or visiting drivers where they are required to enter operational areas).

Any permanently fitted lights, retro-reflectors or retro-reflective material must comply with the Land Transport Rule: Vehicle Lighting 2004 when driving on public roads.

Protection of drivers, operators or passengers

OPERATOR PROTECTIVE STRUCTURES

Operators of heavy vehicles are at high risk of serious or fatal injury by crushing if their vehicles roll over, tip on to their sides or objects enter the cabin. Generally, the risk depends on the terrain and task. For example, there is a low risk on flat, stable ground, and high risk on steep or unstable ground, or on work adjacent to embankments, excavations or working on top of old mine workings.

Fitting roll-over protective structures (ROPS) and wearing a seatbelt can reduce the risk of serious or fatal injury in the event of a roll-over or tip-over. Where there is risk of objects falling onto the operators or entering the driving position (such as rock falls) the operator also needs the security of a falling object protective structure (FOPS).

Extractives operations with a mechanical management plan should address the fitting of devices to protect the operators of mobile plant, including roll-over protection and falling object protection.

For more detailed information on design and types of operator protective structures, see the [Approved Code of Practice for Operator Protective Structures on Self-Propelled Mobile Mechanical Plant](#)

SEATBELTS

All drivers and passengers should wear appropriate seatbelts. Seatbelts should be checked immediately if:

- the buckles are not working properly
- the belt is damaged or faded
- the belt starts to fray
- in-use alarms are defective.

Specific legal requirements for safety belts have changed over time and differ depending on the age and type of vehicle. The type of belt has also changed from static belts to retractor belts. For more detailed information on seatbelts for vehicles, see the NZTA website.

Full harness seatbelts assist the driver to stay within the seat and reduce the effects of body stressing. There are systems available that monitor whether the driver is wearing a seatbelt.

TRANSPORTING PEOPLE

People should only be transported in vehicles fitted with seatbelts and designed to carry passengers. These vehicles should also ensure driver visibility.

Wherever practicable, carry loads separately from passengers. If the cabin is not separate from the load area (for example, a van), fit a bulkhead or cargo barrier between the load compartment and the cabin. This should be strong enough to withstand a load shifting forwards in an emergency.

Secure small equipment (such as fire extinguishers or tools) which may become missiles in the event of a collision.

VEHICLE FIRES

Typical causes of fires on or in vehicles include component failure and poor or inadequate maintenance. When completing a risk assessment for prevention of fires consider:

The design – for example:

- when replacing hydraulic components, make sure they are 'like for like' and suitable for use. Always consult the original equipment manufacturer (OEM) before making changes
- any maintenance, installations or design modifications that are undertaken off-site are verified before use and are equivalent to the OEM's standards and design
- implementing quality checks or audits by OEM-authorized service providers periodically as a cross check for site maintenance
- using low flammability hydraulic fluids. Note that low flammability and mineral hydraulic fluids should never be mixed. If you are replacing one with the other, ensure a flushing product is used and no residual product remains.

The installation – for example:

- properly fitting any attached or in-situ hoses with approved OEM components
- maintaining hydraulic equipment with the appropriate fit-for-purpose tools
- routinely checking hose clamps for security
- routinely checking for wear of hoses or rigid pipes underneath clamps
- using fire resistant hoses and high temperature tolerant hoses designed for oil operating temperatures greater than 150°C
- installing and evaluating insulation around hot components or insulating hoses near hot components and upgrading to braided armour type hoses

- protecting wiring against fire and making sure connections are appropriate to OEM requirements and are suitably located
- the location and rating of protective devices such as fuses, solenoids and non-return valves.

Inspection and maintenance - for example:

- completing pre-start checks for locating and acting on oil leaks, sprays, stains and bird nests
- the maintenance work order system includes the correct selection, integrity and testing of control measures
- using thermal imaging equipment to detect hot spots and high temperature areas of plant during maintenance programmes
- routinely washing, cleaning, and checking hoses for any sources of rubbing, oily mist or leaks
- carrying out periodic checks on hydraulic braking systems to ensure sound operation, including bearings, brake drums, rotors and callipers
- routinely checking electrical wiring, including insulation
- routinely checking solenoid connections for corrosion and replacing or checking at set engine hours or according to OEM recommendations
- protective devices for solenoids such as fuses.

Emergency preparedness - for example:

- installing suitable and sufficient firefighting equipment (such as fire extinguishers). The type of fire extinguisher will depend on the class of fire you are most likely to experience. For example, powder ABE fire extinguishers are suitable for flammable and combustible liquids, flammable gases, and energised electrical equipment
- communication of fire-related events, maintenance incidents and subsequent attendance and associated follow-up is clear to workers
- fitting appropriate automatic or manually-operated fire suppression. Note the fitting of fire suppression systems is covered by the standard AS 5062:2016 and requires a competent installer that understands the fuel sources and where best to position nozzles to ensure effective suppression
- fitting engine or fuel pump shutdown systems
- fitting mobile plant with a battery isolation switch and, where practical, a fuel isolation system.

Cleaning trailers fitted with tailgates

There have been fatalities and serious debilitating injuries caused by swinging tailgates hitting drivers while they have been cleaning out their trailers. The extractives operator should provide appropriate washing facilities for trucks in safe areas and prohibit all work that places a worker between the trailer body and the tailgate. Trailers should have purpose-built access points and tailgates fitted with positive secondary support mechanisms.

The extractives operator should communicate their site-specific requirements to all drivers, including site drivers and external trucking PCBUs. For more information on overlapping duties for PCBUs, see Appendix E.

14.11 Inspecting and servicing vehicles

Vehicles at extractives sites work in harsh environments and need effective maintenance to avoid developing defects. Establish a programme of daily visual checks (or pre-start checks), regular inspections and servicing schedules according to the original vehicle manufacturer's (OVM) instructions, and the risks associated with the use of each vehicle.

Inspections and maintenance should include, where appropriate:

VEHICLE CONTROL

- Braking systems
- Steering
- Tyres, including condition and pressure
- Safety devices such as interlocks

DRIVER SAFETY

- Seats and seatbelts
- Mirrors, cameras and other visibility aids
- Lights and indicators
- Warning signals
- Windscreen washers and wipers
- Firefighting equipment

VEHICLE MAINTENANCE

- Condition of cab protection devices (such as rops and fops)
- Condition of tailgates
- Condition of hydraulic pipes and hoses
- Fluid levels
- Functional checks on the vehicle
- Other accessories such as quick hitches

Where vehicles are hired, determine who is responsible for maintenance and inspection during the hire period and make this clear to all parties.

Put in place a safe system of work that addresses issues such as safely blocking the vehicle and its attachments, isolating stored energy and preventing the vehicle from inadvertently being started. When using jacks they should be rested upon suitable load bearing substrata. Raised objects should be lowered wherever practicable (such as excavator or loader buckets).

Determine a procedure to address defects where they are found in vehicles or attachments. Such procedures could include:

- recording defects when completing daily visual checklists (pre-start inspections) scheduled inspections, daily visual checklists and maintenance logs
- establishing protocols for safety critical defects (such as when a vehicle should be removed from operation, time frames to fix specific defects).
For example, how deep does a cut in the tyre need to be before it should be replaced?
- a system to isolate vehicles when safety critical defects are found. For example, keys or other starting devices removed and secured until repairs are started.

Maintenance under hydraulically raised parts of vehicles

Many vehicles use hydraulics to raise, lift or move material or parts of the vehicle (such as truck trays, front end loader buckets, excavator booms and drilling rigs). These raised parts have stored energy, and you must provide supports or other devices to prevent raised parts dropping or being lowered while workers are under them.

Consider:

- removing the elevated part before other maintenance work takes place (eliminate the hazard)
- fitting a restraining system to the elevated part
- fitting the tray or bucket with a built-in prop
- ensuring restraining system controls are clearly marked and shrouded or protected from accidental operation
- fitting hydraulic cylinders with centre valves.

Brake testing

A suitable inspection scheme should be in place to ensure brakes are in good condition at all times. This is often combined with other maintenance work.

Electronic brake testing equipment is available to regularly and accurately measure brake performance (for example, an electronic system may be permanently fitted in a haul truck). This will show deficiencies in the brake system before they become a problem. The site Health and Safety Management System should require operation, monitoring and maintenance of brake systems according to OVM recommendations, as a minimum.

It should be ensured that:

- the driver tests the brakes at the start of every shift (pre-start inspection), including the park brake and foot brake
- the condition of brake system components is monitored according to OVM's recommendations, reducing the likelihood of catastrophic failure and ensuring they continue to function as intended
- brake system performance is tested according to OVM's recommendations in both static and dynamic situations
- drivers and maintenance workers can access OVM operating and maintenance manuals at site as appropriate
- braking system repair, monitoring, inspection and testing records are readily available at site
- drivers and maintenance workers are trained in the relevant aspects of braking systems
- safety critical aspects of vehicle operation, including emergency braking systems, retarders and other control measures available in the event of engine failure (for example, accumulators), are incorporated into driver training and assessment processes, with appropriate input from competent maintenance workers
- operating and brake maintenance practices for contractors' vehicles are not inferior to the vehicle maintenance practices adopted by the site
- contractors' vehicles are not allowed to operate on site unless maintenance and testing records are checked to verify the integrity of brake systems
- brake maintenance, including processes used for contractors' vehicles, is regularly audited for effectiveness
- if OVM manuals cannot be obtained (for example, due to the age of vehicle), prepare manuals so effective brake system operation and maintenance strategies can be established. Use people with appropriate skills and technical expertise to facilitate the process.

Brake system maintenance strategies

Correct brake system functioning depends on the condition of system components, which in turn depends on the quality of the maintenance. Any brake system maintenance strategy should focus on detecting and rectifying a defect before it results in a loss of brake function.

Brake system maintenance strategies should initially be based on the OVM recommended maintenance programmes, and on condition monitoring, inspection and testing schedules. OVM stipulated operating procedures and repair techniques help make sure brake system integrity is not compromised.

The OVM information should be stored, maintained, updated and be readily accessible by relevant workers, whether it is in hard copy, electronic copy, or on-line based systems.

Hazard identification and risk assessment aimed at improving brake system reliability should consider anything that could affect the safe operation of vehicles. This could include site conditions, maximum loads, operating speeds, operating grades, effects of heat fade, component failure, and loss of pressure.

Control measures may include more frequent component inspections for wear or damage, and regular brake performance verification techniques. These could include Dynamic Brake Testing (DBT), electronic brake test equipment and thermographic temperature profiling, to detect poor performance.

Remember that a positive DBT result does not necessarily verify brake system integrity or confirm the system has been maintained to OVM recommendations. It only indicates the brakes were effective at the time of testing.

In introducing a DBT programme, the risk assessment to determine appropriate control measures should consider, but not be limited to:

- OVM consultation on any deviations from the stated recommendations
- applying relevant brake performance testing standards or appropriate industry practice
- site facilities and limitations relating to surface, space, and controlling vehicles in case of brake failure during testing
- variations in test methodology and acceptance criteria for different vehicle types and categories (for more detailed information see *AS 2958.1-1995 Earth-moving machinery - Safety - Wheeled machines - Brakes*)
- reliability of the DBT test instruments
- applicability and integrity of the standards, procedures and methods used to interpret the results
- training and competency of workers conducting the tests.

Industrial trucks and load shifting equipment (forklifts, mobile cranes)

Inherent instability and lack of traction of forklifts and cranes, particularly on ramps and slopes, present a challenging risk management task. Operators should understand the brake system design limitations and that brake system monitoring, inspection, testing and maintenance are appropriate for the risks in particular applications.

The Australian Standard *AS 2359.13-2005 Powered industrial trucks - Brake performance and component strength* provides guidance on methods for assessing and testing the performance and components of brakes fitted to industrial trucks with rated capacities up to, and including, 50t.

Safe forklift operation on gradients largely depends on the type, size and design of the forklift. Ask the OVM if you are unsure of the braking system's performance capabilities.

14.12 Tyre safety

Large tyres and wheel assemblies are heavy objects, but when they explode, they are thrown violently by the force of the escaping compressed air. An exploding wheel is a high-speed projectile that can kill or seriously injure anyone in its path.

Tyre handling

The tyre and wheel assemblies of large vehicles are usually too heavy to be manually handled safely. The safe fitting and maintenance of large earthmoving tyres and wheel assemblies can only be undertaken using specialist tyre-handling equipment. Special attachments may be required on standard handling equipment (such as forklifts) to deal appropriately with large tyres and wheels.

A variety of tyre-handling attachments is commercially available for use with forklifts, hydraulic vehicle-mounted cranes and tyre handlers, loaders, integrated tool carriers (ITCs) and other multipurpose machines.

The responsible person should make sure the machines used are:

- fit for purpose
- safe to use
- adequately inspected and maintained, with appropriate records being kept.

Operators should be adequately trained and assessed as competent to operate the particular type of machine and tyre-handling attachment.

Robotic and remotely operated tyre- and wheel-handling equipment could be considered during the risk assessment.

Lifting tyres with a crane

When lifting and moving tyres as a freely suspended load, using a crane:

- make sure the rated capacity of the crane is appropriate for the weight of the tyre being lifted or moved
- make sure a mobile crane and its suspended load remain stable whether the crane is stationary or tramping
- maintain an exclusion zone around the work area
- never work beneath a suspended tyre
- stay clear of any slings being used
- do not use chains to lift or suspend a tyre
- avoid damaging the bead, by not allowing rope slings to rub against the bead area of the tyre. If a tyre must be lifted using a crane, use a wide fibre sling or belt to prevent damaging the bead.

Lifting with a forklift

When lifting and moving a tyre with a forklift:

- make sure the rated capacity of the forklift is appropriate for the weight with the mass of the tyre being lifted or moved
- consider the stability limits of the forklift and the ground conditions where it will be travelling with the load
- secure the tyre with suitably rated tie-down straps, as a minimum
- consider using a specifically designed rubber-coated cradle or slipper extensions on fork tynes to provide adequate support when lifting or transporting the tyre
- always lift the tyre at its outside circumference, never insert the fork arms through the centre of the tyre as this can damage the bead, resulting in premature failure when the tyre is inflated

- operate the forklift in reverse, if the load obstructs the forklift driver's view, and enlist a spotter to assist with manoeuvring, or do both,
- consider equipping the forklift with reversing cameras or other proximity detection aids as part of the safe system of work.

Clamp-type tyre manipulators

When using clamp-type tyre manipulators:

- match tyre-handling attachments to multipurpose mobile plant (the combination of plant should be assessed and deemed safe to use)
- make sure that tyre-handling attachments are only used with machinery that is accepted by the manufacturer of the earth-moving machine and attachment
- verify the competency of the operator of the tyre-handling attachments
- consider safety factors in design between manufacturers and make sure the machines used are fit for purpose
- inspect the machinery and assess the job risks before commencing work, taking prevailing weather conditions into account
- park and isolate the machine on a suitable stable surface, at a safe distance from other activities
- based on a risk assessment, create a clearance zone large enough for the tyre handler to work and move
- operate the tyre handler within its rated capacity and according to the manufacturer's instructions (a copy of the manufacturer's operator manual, maintenance manual and logbook should be available to the operator)
- deflate tyres to the nominal handling pressure recommended by the site procedure for the task being undertaken or for storage
- make sure gripping pads have full contact with tyre treads before lifting
- if you are using a two-arm tyre handler to move tyres, travel at a safe speed with the tyre low to the ground and in the horizontal position, with the arms of the tyre handler tilted back
- only rotate the tyre into the vertical position when necessary.

Working with compressed air

The eyes are particularly at risk when compressed air is in use, both from high-velocity air and from particles of dust, metal, oil and other debris, which can be propelled by the air. Suitable eye protection should always be worn.

Suitable overalls or other substantial clothing will protect the skin from fine particles and debris, provided they are not blown at a high velocity. However, overalls cannot offer protection against high-velocity air at close range. Particles can be blown through overalls and skin and into the body. Air can be blown into the bloodstream, causing swelling and intense pain, particularly if any cuts, punctures or sores are present, making entry easier. The air can be carried to the small blood vessels of the brain, lungs or heart, resulting in death. Workers should not use compressed air to dust themselves down.

All pressure gauges and control devices should be checked against a master pressure gauge at regular intervals or immediately after any heavy impact or other damage.

Compressed air hand tools, as well as compressors and associated equipment, should be maintained and checked regularly.

Tyre safety cages and exclusion zones

Most car or light vehicle wheels and tyres are strongly constructed and have a small internal air volume. They therefore do not require high pressures. Such tyres pose minimal risk to the service person and, if correct fitting procedures are adhered to, problems would not normally be expected. However, some light vehicles have divided wheels that require cage inflation. In general, inflate light vehicle tyres with the jaws of the tyre-fitting machine restraining the wheel.

It is strongly recommended that all tyres, including small units, be inflated within a suitable restraint.

Tyres on split-rim and detachable-flange wheels should be contained by a cage guard, or other suitable restraining device, when being inflated after being dismantled or repaired.

Tyres that have a large volume, or are inflated to high pressures, should be contained by a cage guard or other restraining device when being inflated, after being repaired or otherwise removed from the wheel. This includes truck, forklift or earthmoving plant tyres.

If restraints are not available, a suitable system of work is to be used, such as inflating from behind a barrier.

When a tyre has to be inflated while it is still on the vehicle, an exclusion zone should be established during inflation.

Exploding wheels and tyres

Divided wheel, split-rim and locking-rim wheel and tyre assemblies are especially likely to explode if poorly maintained, incorrectly fitted, or if assembled or disassembled while inflated.

The most common faults are:

- over-inflation
- removal of split-rim fastening nuts instead of wheel fastening nuts
- failure to ensure correct seating of split rims or tyre beads
- the use of damaged parts, or replacement parts with lower strength than the original equipment.

Non-original after-market nuts and bolts and other fixings could be inadequate.

The inflation system should be fitted with a device that prevents over inflation.

It is essential to deflate tyres before wheel removal to ensure removing the wrong nuts does not result in a serious or fatal accident.

All off-road vehicles should have a maintenance system in place for rims and wheels in accordance with *AS 4457.1 Earth Moving Machinery – Off-the-road wheels, rims and tyres – Maintenance and repair – Wheel assemblies and rim assemblies*.

Fires and explosions of tyres in service

The primary cause of tyre fires is the application of heat to the tyre, or development of heat within the tyre structure, which can result in an explosion of the tyre.

Heat can be conducted through the rim base to the bead area of the tyre where a small quantity of rubber can be pyrolyzed. The gases given off in the process can be ignited by the continued application of heat. An explosion could originate from the point of heating, with the flame fronts travelling around the tyre in opposite directions and causing a rupture where they meet.

A temperature rise sufficient to cause problems can be generated by other sources of heat, such as:

- electrical earthing through the tyre as a result of lightning strike or powerline contact
- wheel component heating through misuse of brakes or electric-wheel motor problems
- internal tyre damage as a result of excessive speed, road camber deficiencies and ply separation.

An uninflated tyre may explode in the same manner as an inflated tyre if sufficient heat is applied to it.

Other factors that can increase the likelihood of a fire or explosion include:

- auto-ignition temperatures of different types of bead lubricants and other introduced materials, which can vary widely. Before any material is introduced into the tyre air chamber, its auto-ignition temperature should be checked, and if the figure is lower than that for the tyre liner or bead, it should not be used. Auto-ignition information can be found on a product's safety data sheet (SDS).
- accidental use of an incorrect inflation medium (such as LPG or other explosive gases) through contaminated air supply or other means.
- carbon dust given off from pyrolysis of the tyre liner, which can auto-ignite at temperatures as low as 200°C, the lowest auto-ignition temperature of any material likely to be encountered in a tyre.
- low flash point fuels and solvents, which can be absorbed by tyre rubber. This can increase the likelihood of a tyre catching fire where a heat source is introduced, increase the seriousness of any fire that does eventuate, or both.

A tyre explosion can occur even where no fire is visible. Smoking tyres or brakes should be treated as a potential tyre explosion and the vehicle isolated accordingly.

Prevention of tyre fires

To prevent tyre fires, you should:

- ensure correct inflation of all tyres and check on a daily basis
- ensure no hot work is undertaken around the wheels and rims
- make sure trucks are not overloaded
- consider installing on-board tyre pressure and temperature sensors.

Prevention of tyre explosions

To prevent tyre explosions consider implementing these options:

- Nitrogen inflation: nitrogen inflation will significantly reduce tyre explosions.
- Inhibiting agents: consider the use of fire inhibiting agents and fireproof coatings on the inner surface of the tyre.
- Earthing vehicles: consider earthing vehicles against lightning strikes so the tyres do not provide the earthing path.

Combating tyre fires and potential explosions

If a vehicle catches fire or a heat source is recognised and there is a potential for a tyre explosion, you should immediately establish a prohibited zone of at least 300m around the radius of the vehicle. The prohibited zone should remain in place for at least 24 hours following the removal of the heat source. An emergency crew should remain in attendance during this period.

14.13 Maintenance and repair of roads

Roads and other vehicle operating areas should be regularly maintained so they do not develop bumps, ruts or potholes. These may make control of vehicles difficult or cause health problems due to whole-body vibration. In addition, excess mud and slurry can seriously affect the manoeuvrability and braking potential of the vehicles using the road and other vehicle operating areas.

Dust suppression

Dust generated by moving vehicles can reduce visibility to dangerous levels and create a health hazard. Dust is typically reduced by applying water to the road surface. In dry conditions, watering helps maintain compaction and surface pavement strength. It also maintains the pavement shape, reduces the loss of gravel, and helps reduce corrugation of the road surface.

The quantity of water needed to control dust depends on the nature of the road surface, traffic intensity, humidity and precipitation. During drier months, a typical road may need one to two litres per square meter per hour. Liquid stabilisers and polymers can also be used, which can help strengthen the surface layer and provide a degree of water proofing.

Where water restrictions are an issue, consider reducing speed limits and constructing the road with an alternative material so the surface is less dust prone.

Waste oil or other hydrocarbons should not be used to suppress dust due to environmental concerns and traction issues when wet.

Safety when watering roads

Watering roads to suppress dust has the potential for vehicle accidents. The water tanker could turn over or the roads could become slippery because of wet bends, downgrades and any other sections of road where brakes may be applied (such as intersections).

Water tanker drivers should avoid driving across gradients due to the potential increase in instability of trucks carrying fluids. As a hazard control, consider installing baffles in tanks carrying fluids to help prevent movement of water inside the tank.

'Patch' or 'spot' spray roads, and avoid blanket spraying or depositing large amounts of water on the roads (especially in braking areas, gradients and junctions of haul roads). It is recommended water tankers are fitted with systems that can be effectively controlled by the operator to manage water output.

The sequencing of haul trucks following the water cart should be risk assessed to ensure the sprayed water will not cause traction issues for the haul trucks.

Regular inspections of the road surface should be made to ensure that dust is suppressed, and adequate traction is maintained.

Procedures for watering roads should detail actions to take when roads have been excessively watered, reducing traction. This is particularly important on haul roads.

Where possible, water tankers should be filled at the lowest point, and dust suppression applied travelling up hill. This will avoid fully loaded water tankers travelling downhill reducing the potential for the loss of vehicle control due to traction loss or brake failure.

15.0

Plant and structures

IN THIS SECTION:

- 15.1 Scope
- 15.2 Existing plant and structures
- 15.3 Identification and risk assessment of plant and equipment hazards
- 15.4 Mechanical or electrical management plan
- 15.5 Choosing, buying and upgrading plant and structures
- 15.6 Positioning of plant and structures
- 15.7 Access routes
- 15.8 Guarding
- 15.9 Guarding and maintenance
- 15.10 Conveyors
- 15.11 Emergency stops
- 15.12 Pre-start warning systems
- 15.13 Electricity
- 15.14 Cranes and lifting equipment
- 15.15 Maintenance of plant and structures
- 15.16 Common hazards when undertaking maintenance
- 15.17 Lockout and tagout processes
- 15.18 Permit to work systems

All sites use plant and structures in their day-to-day workplace activities. If hazards associated with plant and structures are not safely managed, then serious injury and death can occur.

This section describes how to:

- identify and manage equipment hazards (for new and existing plant and structures)
- position and guard equipment
- use pre-start warning systems and emergency stop systems effectively
- prevent, detect and deal with fires and explosions
- manage electrical hazards
- manage specific hazards around lifting equipment, floating equipment and portable ladders
- safely work near highwalls or faces.

15.1 Scope

HSWA defines 'plant' as including any machinery, vehicle, vessel, equipment, appliance, container, implement or tool, as well as any component of those things or anything fitted to those things. 'Structure' is defined as anything that is constructed, whether fixed, moveable, temporary or permanent - including buildings, masts, towers, frameworks, pipelines, bridges, quarries, shafts or tunnels - as well as any component or part of a structure.

On extractives sites, this scope of plant and structure covers almost any equipment used at work including:

- hand tools such as hammers and handsaws
- individual machines such as circular saws or trucks
- apparatus such as laboratory apparatus (for example, density meter)
- lifting equipment such as hoists, forklifts, elevating work platforms or lifting slings
- other equipment such as ladders, pressure water cleaners
- installations such as crushing plant and associated conveyor systems, buildings, material bins and walkway structures.

This section covers plant and structures commonly used at extractives sites, where the information in supporting documents, such as other WorkSafe guides, may not be sufficient to provide industry specific guidance.

15.2 Existing plant and structures

You need to know what the hazards are with your plant and structures, so you can address those hazards. The first step in the hazard management process is to identify hazards – anything that can injure or harm someone. To identify hazards, it is useful to first identify all plant and structures at your site.

Do a workplace inspection to identify all plant and structures. Include common items that may not usually be thought of as ‘plant’. Also consider how other workplace items such as steps or platforms can affect the use of your plant and structures.

Once you have identified all plant and structures, you can identify their hazards.

With changes in technology and cost of solutions over time, measures to eliminate or isolate a hazard may become practicable. You should continue to assess significant hazards to determine whether there are other methods to control them. For example, replace a plant with newer plant that eliminates the hazard. You should also routinely review systems, procedures and standards to reflect changes in technology and best practice. For example, reviewing industry safety alerts and insights from incidents relating to plant and structures and other extractives sites.

15.3 Identification and risk assessment of plant and structure hazards

Identify hazards using physical inspection, task analysis, process analysis, risk assessment process, guidance and standards, hazard and operability analysis (HAZOP) and accident investigation analysis. You must engage with your workers in the identification of hazards.

When identifying hazards associated with plant and structures and undertaking a risk assessment, consider:

- how plant and structures might feasibly fail, and the likely consequences of any such failure (for example, structural support collapse)
- the type of fuel or energy used to power plant, equipment or installations used at the site (such as electricity, gas or petroleum)
- what the possible consequences of a loss of control situation would be (such as mechanical failure leading to uncontrolled release of hazardous substances or energy sources)
- the hazards relating to moving parts (such as draw-in hazards, nip-points, entanglement hazards)
- the hazards relating to suspended parts
- the hazards relating to surfaces (very hot or very cold).

For more detailed information on identifying, assessing and controlling hazards, and on assessing and managing risks, see Section 2 of this guide, along with our [Safe use of Machinery Best Practice Guidelines](#)

If the likelihood or consequence of the risk posed by a hazard is not clear, seek the advice of a specialist mechanic, designer, engineer or the machinery or equipment’s original manufacturer.

15.4 Mechanical or electrical management plan

When developing a management plan for mechanical hazards, do a risk assessment and consider:

- the standards of engineering practice to be followed throughout the life cycle of the mechanical plant and installations
- the safe operation of conveyors, winding systems, mobile plant and dredges
- the safety of plant and installations
- rollover, falling object and cabin intrusion protection
- seatbelts and other restraints
- protective canopies
- safe storage and use of pressurised fluids
- means for the prevention, detection and suppression of fire on mobile plant and conveyors.

When developing a management plan for electrical hazards, do a risk assessment and consider:

- prevention of harm from electrical sources
- prevention of fires being started by electricity
- prevention of unintentional starting of electrical plant
- fitting electrical safeguards
- competencies required for workers carrying out electrical work
- the reliability of plant and installations used in monitoring hazard control measures and communication systems
- a maintenance management system
- safe work practices for working on high voltage installations
- any other requirements of the MOQO Regulations in relation to the safety management of electrical plant and installations and electrical engineering practices
- the requirements of regulations made under the Electricity Act 1992.

The Electricity (Safety) Regulations 2010 contain specific requirements for extractives sites, including:

- mobile and relocatable mining electrical equipment used at extractives sites
- work on or near bare live conductors
- record keeping and plans
- prescribed electrical work.

Develop the plans and procedures for mechanical and electrical hazards in the context of the whole health and safety management system. They should not be developed in isolation from other plans, processes and procedures that rely on the control. This will ensure gaps and overlaps in information and procedures are identified and used in the implementation of suitable control measures to minimise the likelihood of potential risks and impacts.

15.5 Choosing, buying and upgrading plant and structures

The most efficient and cost-effective time to ensure plant and structures are safe is when they are being scoped, designed and purchased. All operators should specify their expectations for achieving safety standards.

The designer, manufacturer, supplier and employer have obligations under HSWA and the MOQO Regulations and should work together to manage aspects such as:

- how the plant and structures are used in the workplace
- risk levels and standards required

- type of guarding based on work activity
- who will provide, install and commission the plant or structures
- integration with other plant or structures
- the working environment in which the plant or structures will operate
- any hazardous exposures arising from use of the plant or structures, such as noise or fumes
- who will train and supervise the operators
- operations and maintenance procedures
- intrusive maintenance and internal inspections required
- potential blockages or unusual situations
- how isolation from hazardous energy can be achieved.

Where the plant or structures are being designed and manufactured in-house, you take on the responsibilities set out in HSWA sections 39 and 40. As the designer you must have health and safety, including relevant standards, in mind when developing design concepts and throughout the design process.

If newly purchased plant or structures are not safe because of the way they have been designed, constructed, supplied or installed, you should stop using them until this has been fixed. Contact the manufacturer or supplier (or installer if relating to the installation) to resolve the issue.

For more information about overlapping duties, see Appendix E, and for upstream duties relating to the supply chain, see Appendix G.

15.6 Positioning of plant and structures

As a general rule, activities such as crushing and screening are noisy and dusty, so they are positioned away from boundaries to lessen the nuisance of the activities. Some noisy and dusty processes may need to be housed to control these effects.

The safety of workers in the processing area is paramount. Traffic should be routed around the plant and structures wherever possible, and plant and structures should be sited away from hazards such as unstable ground (for example, rock falls, ground settlement or historic underground workings) or overhead power lines.

Services, including electricity, air and water should be included in a site layout plan, particularly when placed underground.

15.7 Access routes

Plant and structures, including mobile crushers, often have areas where access at height is required to carry out routine operations, undertake maintenance or access control rooms.

For structures defined as buildings under the Building Act 2004, the Building Code specifies you must provide reasonable and adequate access to enable safe and easy movement of people. When planning, designing and constructing access routes, you must also consider your obligations under HSWA and the MOQO Regulations.

For the design, construction and installation of platforms, walkways, stairways and ladders on extractives sites, the standard *NZS/AS 1657 Fixed platforms, walkways, stairways and ladders* sets out specific requirements.

The site's traffic management plan should provide for safe means of transport for worker's access to their place of work within the operation.

15.8 Guarding

Where elimination of a hazard is not reasonably practicable, guarding is an effective isolation control provided the guards are the correct ones, and they remain in place.

The fundamental principles of guarding machinery are covered in our Safe Use of Machinery Best Practice Guidelines, and Ergonomics of Machine Guarding Guide.

This section provides additional guidance on effective guarding on fixed and mobile processing plant typically found in quarries and mines. It is not intended to be a comprehensive list, and you may determine other types of guarding are more suited to the circumstances at your site.

Perimeter fencing (or area guards), although commonly used at extractives sites, does not meet the minimum requirements of the standard *AS/NZ 4024.1 Safety of machinery* when workers require access within the perimeter while the machinery is running. In these situations, fixed guards should be used to guard individual nip-points and entanglement hazards.

Extractives sites should assess their plant and reference what type of guarding is required by *AS/NZ 4024* (for example fixed guarding or interlocked guards).

See Figures 81 to 90 for examples of fixed guards.

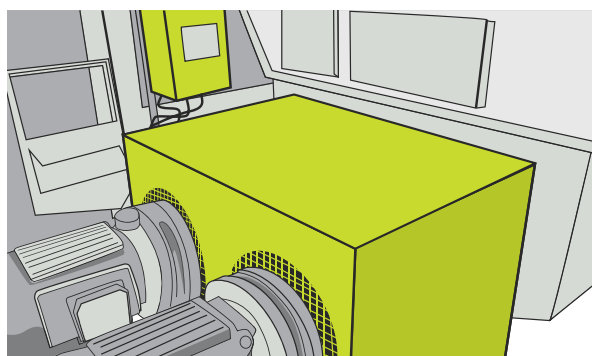

FIGURE 81:
Example of fixed close-fitted guard enclosure on direct drive electric motors

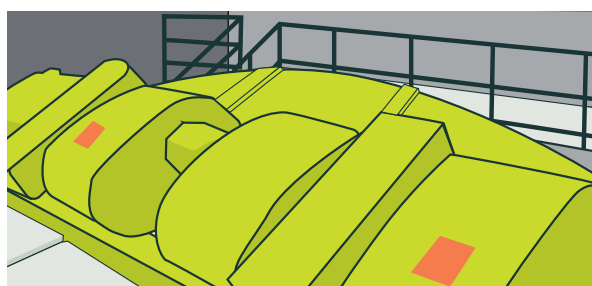

FIGURE 82:
Example of totally enclosing sheet metal guard, suitable for vibrating units with additional guards over the associated shafts and couplings

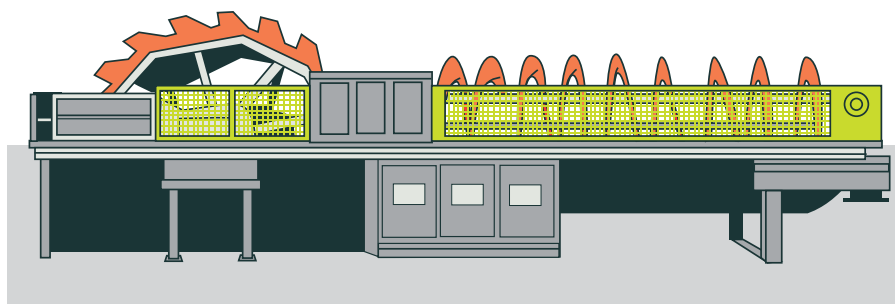

FIGURE 83:
Example of panel mesh guards on fines dewaterer

Fines dewaterers use slowly rotating scraper blades to extract the finer particles. In addition to a sheet metal guard on the main dewatering section, a mesh guard should be provided around the trough of the scraper blade section. This should be fitted high enough to avoid workers falling into the trough or being able to reach the scraper blades and be at least 2.7m above ground level.

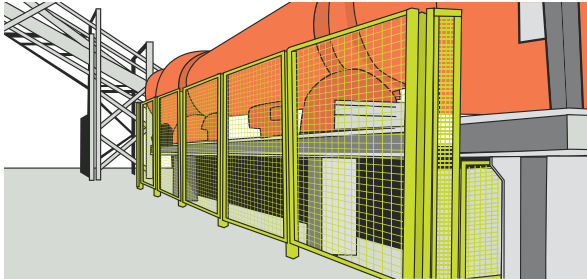

FIGURE 84:
Example of panel
type guards on dryer

Panel type guards secured to fixed uprights may be suitable for large rotating cylinders such as screens, dryers and trommels. The minimum height of the guard should be 2.7m. Access gates should be interlocked unless access is required less than once per shift, in which case a fastened gate can be used (must require a tool to open).

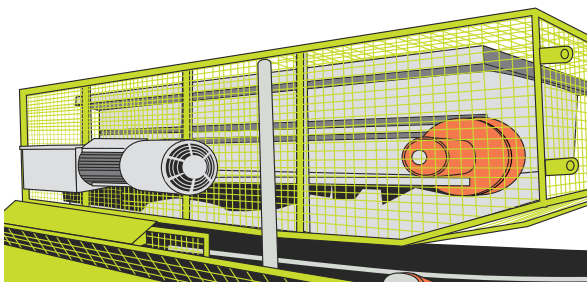

FIGURE 85:
Example of close
fitted guards on
batch feeder belts

Batch feeder belts, while generally slower, have the same hazards as a normal conveyor. The feeder and all associated nip-points should be enclosed within suitable guards fitted along the full length of the feeder. Guards should be provided on the underside to prevent access to tail and head drums.

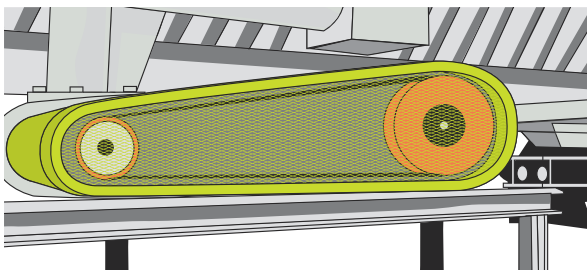

FIGURE 86:
Example of close
fitted guards on
vee-belt drive

Vee-belt drives are commonly used on various items of plant. Open mesh guards help with efficient cooling of the vee-belts and pulleys and allow vee-belt tension to be visually checked without removal of the guard. The guard should fully enclose the front and back as required to prevent access.

As with vee-belt drives, a fixed guard totally enclosing the drive is suitable for primary jaw crusher drives. Alternatively, guarding fitted around existing structures may be suitable.

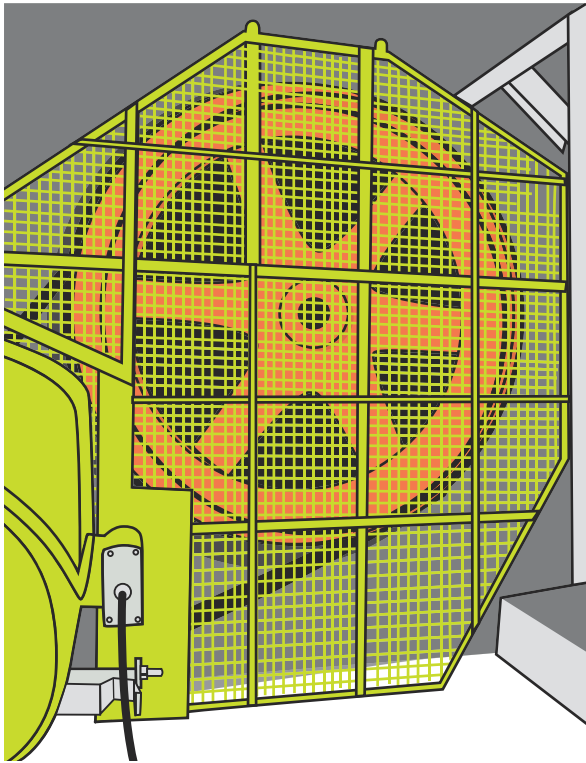

FIGURE 87:
Example of a vee-belt
with a fixed guard totally
enclosing the drive

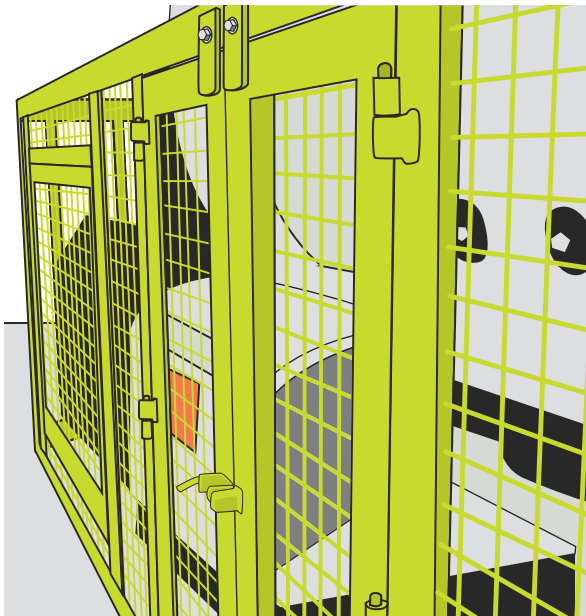

FIGURE 88:
Example of hinged
access panel guard
bolted shut

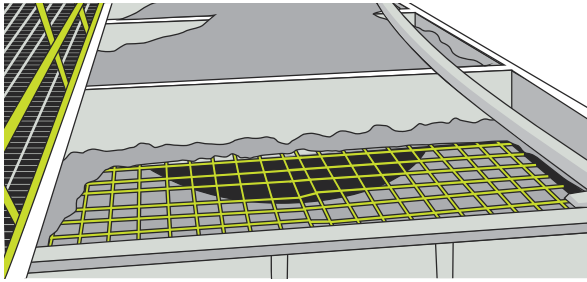

FIGURE 89:
Example of steel grid
on elevated feed hopper

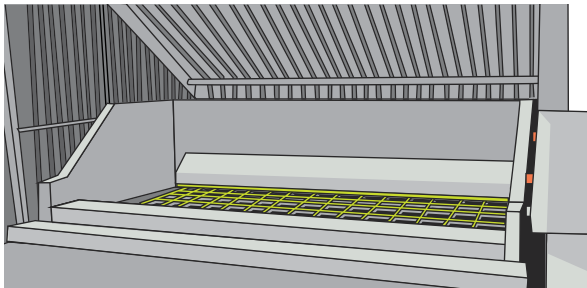

FIGURE 90:
Example of steel grid
on ground feed hopper

Steel grids, with sufficient strength to withstand any anticipated loads, should be provided in the top of all ground feed hoppers and easily accessible elevated feed hoppers. This is to prevent unauthorised or inadvertent entry. The exception is with primary hoppers or where products of a large dimension are being processed which may obstruct the grid.

Fitting grids on elevated hoppers may encourage people to walk on them next to an unprotected edge. Appropriate access prevention measures should be incorporated in the design (such as barriers).

Provision should be made to enable drivers at ground feed hoppers to release tail gate latches from a position of safety.

Conveyor guarding

Most serious accidents and fatalities with conveyors result from the machinery, and associated in-running nip-points, not being adequately guarded.

A wide variety of mechanical motions and actions on a conveyor system will present hazards to the worker. These can include the movement of rotating parts, moving belts, meshing gears and any parts that impact or shear. These different types of hazardous mechanical motions and actions are basic in varying combinations to nearly all machines. Recognising them is the first step toward protecting workers from the hazards they present.

On a conveyor, in-running nip-points are dangerous trapping points at the line of contact between the rotating drum or pulley (cylinders) and the moving conveyor belt on the in-running side of the cylinder. A similar point on the out-running side of the cylinder where the conveyor belt exits is not a dangerous location unless the conveyor can be reversed.

Even smooth, slowly rotating cylinders can grip clothing, and can, through skin contact alone, force an arm, hand or body into a dangerous position. Often the machine is running too fast or is too powerful to allow the person to stop the machine or pull the body part out. This can result in severe friction burns, amputation or significant (including fatal) crushing injuries.

Where a moving part cannot reasonably practicably be eliminated, and workers are exposed to potential contact, fitting fixed barrier guards and additional in-running nip guards are practicable isolation control measures.

Hazardous trap points may occur at a variety of locations, including:

- power transmission moving parts
- head and tail end pulleys
- bend, snub and take-up pulleys
- carrying and return idlers beneath feed hoppers, skirt plates and where the lift of the belt has been restricted as well as at convex curves (brow position)
- roller assemblies for conveyor belt tracking
- idlers accessible to people such as from crossovers or underpasses, maintenance or storage areas or cleaning areas and transition idlers adjacent to pulleys
- drive drums.

The following pages outline possible guarding for conveyor belt parts in operation, including:

- power transmission moving parts
- belts
- upper and lower strands in a straight run
- curved zone (brow positions)
- head and tail drums and transition zones
- gravity take up units
- fixed obstacles
- skirt boards.

It also provides general information on the use of nip guards.

POWER TRANSMISSION MOVING PARTS

Hazards associated with power transmission moving parts include the drive shaft, shaft end, sprocket, pulley, chain, drive belt and gear coupling. Possible consequences include drawing-in and crushing, as well as entanglement of a loose piece of clothing in a protruding moving part.

If a hazard is less than 2.7m from the ground, working platform or any other location (for example, stockpiles), fixed barrier guards should be fitted.

BELT

If the belt is in good condition, possible consequences of contact (depending on the speed and belt characteristics) include friction burns or abrasion and impact with the belt.

Install hazard control measures in accordance with the results of your risk assessment.

If the belt is not in good condition, or there is evidence of a damaged belt splice, drawing-in, burns and lacerations may be possible. Change the belt splice design or manufacturer if this is an ongoing problem. Otherwise maintain the belt and belt splice according to the manufacturer's specifications.

UPPER AND LOWER STRANDS IN A STRAIGHT RUN

An in-running nip will be present between:

- the upper strand and the pulleys under the hopper
- the upper strand and the pulleys under the skirt-board or skirt
- the upper strand and support rollers
- the upper strand and return rollers
- the lower strand and scrapers.

The following figures show suggested guarding in these areas.

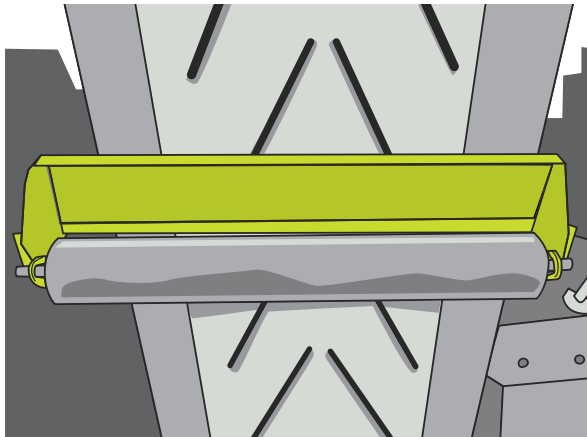

FIGURE 91:
Plate type guard

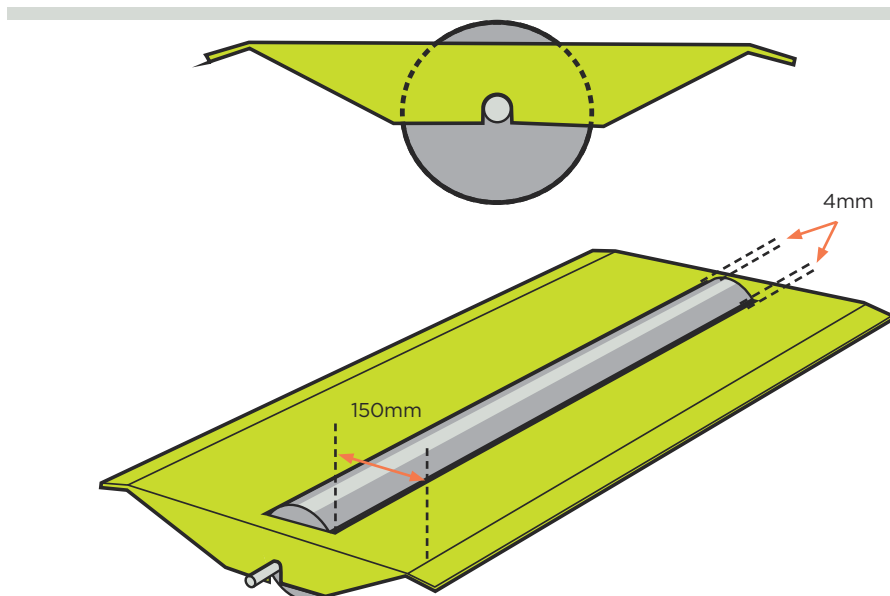

FIGURE 92:
Bottom idler nip guard

CURVED ZONE (BROW POSITIONS)

In-running nips will be present between the belt and rollers in the curved zone with a possible drawing-in consequence. Fit a fixed barrier guard and, where required, additional nip-point guards.

HEAD AND TAIL DRUMS AND TRANSITION ZONE

In-running nips with a possible drawing-in hazard are present:

- between the belt and drums
- at the junction between two conveyors
- between the drum and fixed support brackets
- between the upper strand and the load carrying rollers in the transition zone.

Entanglement hazards also exist where the shaft is exposed. A fixed barrier guard and additional nip-point guards should be fitted.

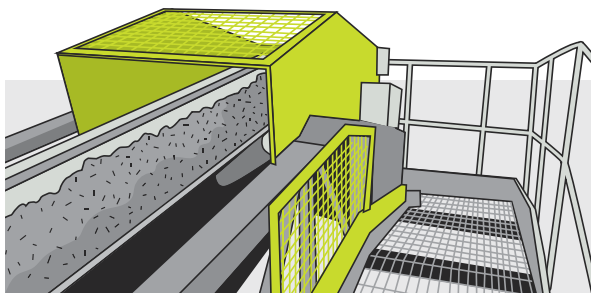

FIGURE 93:
Example of head
drum guards

Head drums, which may become accessible by climbing stockpiles, should be guarded. Alternatively, stockpile heights should be strictly maintained to below 2.7m in accordance with the reach distances specified in the standard *AS/NZ 4024.1 Safety of machinery*.

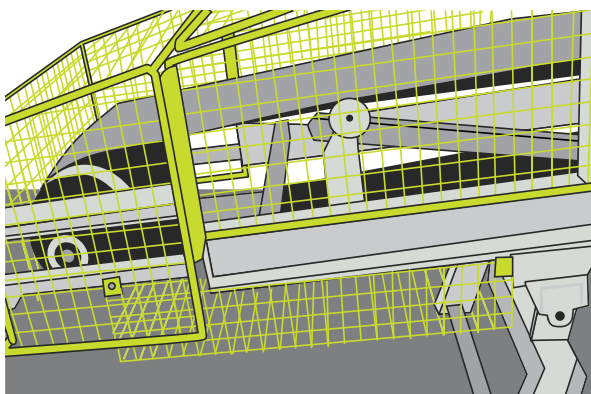

FIGURE 94:
Example of tail
drum guard

GRAVITY TAKE-UP UNITS

Conveyor gravity take-up units should be enclosed with mesh panels which prevent access to moving parts within the structure. This prevents the risk of the gravity take-up weight falling to ground level in the event of the belt, chains or ropes breaking. All panels should be secured so they require a tool for removal, or should be interlocked.

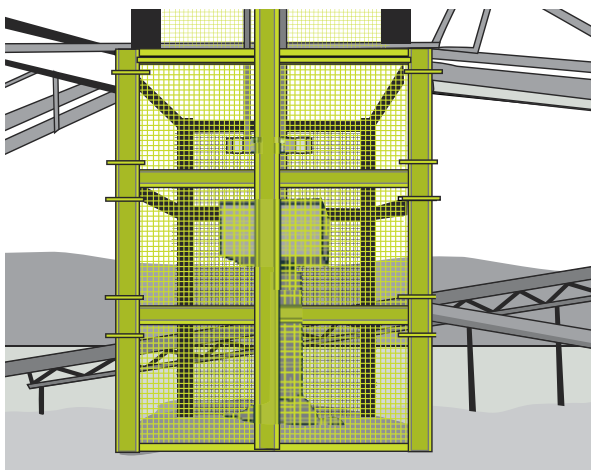

FIGURE 95:
Example of perimeter
guarding on gravity
take-up points

FIXED OBSTACLES

Fixed obstacles which are not part of the conveyor can result in a person being trapped between the load and the fixed object. Examples of fixed objects are:

- posts
- walls
- tunnel entrances
- associated fixed equipment (such as metal detectors)
- large bulk loads (such as boulders).

In relation to your risk assessment results, consider fixed guards and deterrent devices. The objective is to keep the body, arms and legs away from the crushing area. The type of guard and its dimensions will depend on the body part at risk of being trapped and the weight of the load. Ensure that the guard itself does not create a drawing-in or trapping area.

SKIRT BOARDS

The MOQO Regulations specify that you must ensure conveyors are designed, installed and used in such a way that no one is struck by falling objects. The use of skirt boards can limit the amount of material that falls from conveyors (see Figure 96).

Install skirt boards or other protective devices at:

- loading and transfer areas. It is recommended that the skirt boards be at least two and a half times longer than the belt is wide, to allow the material to 'settle down'
- areas that have unusual features, such as magnets, crushers and grizzlies
- places where people pass under the belt
- areas where maintenance, clean-up or inspection activities are frequently performed.

In situations where fixed skirts are fitted above conveyor idlers, a trap point exists between the idler and the belt. Panels of guards should be fitted to prevent access to the trap points associated with the skirts of the conveyor (see Figure 96).

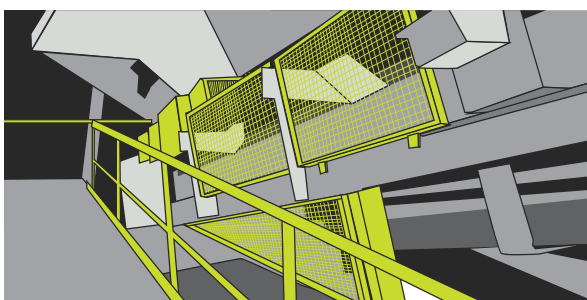

FIGURE 96:
Example of
skirting guards

General information on the use of nip guards

Nip guards prevent access to the in-running nip's drawing-in zone. Where practicable, the nip guards should fill the drawing-in zone as much as possible and should be sufficiently rigid not to increase the clearance between the guard and the cylinders or the belt.

However, nip guards do not protect against the risk of pinching between the guard and the cylinder or belt, so residual risks of abrasion or burns may remain.

They also do not provide appropriate protection against the risks of hair or clothing being drawn in. Therefore, the risk assessment should take into account that the drawing-in effect increases with the diameter of the rollers, their roughness, their rotational velocity and the clothing or PPE worn (for example, gloves).

To limit the risks of pinching, abrasion and burns, the clearance between the nip guard and the cylinder or belt should be as small as possible (maximum 4mm). The angle between the guard and the tangent to the cylinder or between the guard and the belt should be 90° or slightly larger.

Nip guards are particularly suitable for cylinders, drums and rollers with a smooth and full end disc. They can be used with a smooth, flat or troughed belt, if they follow the profile of the belt and the belt is tight and does not vibrate.

Where there are other machine hazards that require guarding (for example, head drums with exposed rotating shafts), nip guards should be used in addition to fixed or inter-locked barrier guards.

When designing nip guards, consider the type of product and the moisture of the product being processed, as well as appropriate belt cleaning devices such as belt scrapers.

Drawing-in zones

All in-running nips create hazardous zones (also called drawing-in zones) between the cylinder and the belt, or between two cylinders. In the case of a cylinder in contact with a belt, the drawing-in zone has the shape of a triangle that becomes even more acute when the cylinder radius is large. The zones vary in depth in relation to:

- the diameter of the cylinders
- the gap between the cylinders
- the gap between the cylinder and the stationary object.

To calculate the dimensions of these drawing-in zones for design purposes, see the relevant parts of the following standards:

- *AS/NZS 4024.3610: 2015 Safety of Machinery Part 3610: Conveyors - General Requirements and Part 3611: Conveyors - Belt conveyors for bulk materials handling*
- *ASNZS-4024-36142015 Safety of machinery - Part 3614: Conveyors - Mobile and transportable conveyors*
- *ASNZS-4024-36122015 Safety of machinery - Part 3612: Conveyors - Chain conveyors and unit handling conveyors*
- *ASNZS-ISO-4024-16012024 Safety of machinery, Part 1601: Guards - General requirements for the design and construction of fixed and movable guards.*

Idler roller nip hazards on heavy duty belt conveyors

There is also a significant risk of injury posed by nip-point force on heavy-duty conveyor top and bottom idler rollers and the generally increased accessibility of nip-points due to greater width of idler rollers (particularly bottom idler rollers).

The two main factors to consider when undertaking a risk assessment are:

- **The degree of hazard (likely severity of injury):** Determined largely by the pressure between the belt and the idler roller. For example, if the stationary conveyor belt cannot be lifted off the idler by a person using one hand, it is likely nip guards will need to be installed.
- **The likelihood of access to the nip-point:** Determined by the height of the nip in relation to the activities that could be performed at that location and the separating distance between the nip-point and the likely position of workers that might make contact with it.

Where belts are running at high speed, the risk increases as well, and consideration should be given to fitting nip guards.

Secondary in-running nip guards

Sometimes access is needed behind barrier guards or fixed guards, for the purpose of maintenance and cleaning of conveyor systems. This results in potential exposure of workers to nip-points. In addition, guards are often left off at positions where they have to be frequently removed.

Fitting a secondary in-running nip guard provides protection to workers when the primary guard is removed.

Previous initiatives have involved emergency stop cables interlinked with guards. However, as these are not as effective as nip guards fitting directly at nip-points (in addition to any other guards required) WorkSafe recommends fitting nip guards at nip-points, where practicable.

Consider putting additional control measures in place when performing maintenance, or during commissioning activities. A risk assessment will help determine suitable control measures.

Maintaining nip guards

Nip guards are essential safety devices and must be maintained in effective working order. They should undergo a suitable scheme of inspection, examination and maintenance. Each nip guard should be individually identified in such a scheme to ensure its location is known and each has its own record of inspection, examination and maintenance.

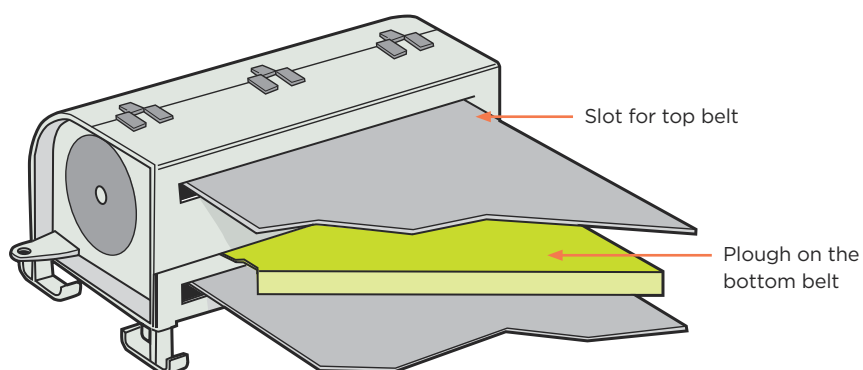

FIGURE 97:
Tail drum return nip guard

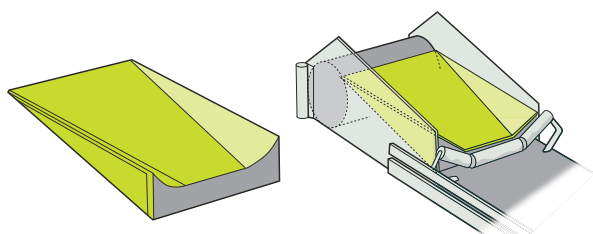

FIGURE 98:
Head drum nip guard

Stone guillotine guarding

Stone guillotines (or stone cutters) with unguarded cutting knives can cause amputations and other serious injuries.

Examples of machine guarding methods include barrier guards, two-handed starting devices, remote-operator controls and electronic safety devices (such as light curtains).

Using machine-guarding methods that eliminate worker access to the cutting knife (called the ‘point of operation’) is the preferred method of hazard control (see Figure 99).

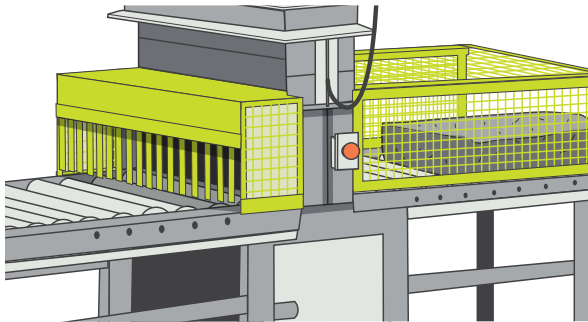

FIGURE 99:
Stone guillotine
with fixed guards

Two-handed starting devices are a cycle-initiation method that requires constant, simultaneous pressure from each hand on two separate controls to move the cutting knife. If the operator removes either hand from either of the controls, the blades will stop immediately. Two-handed starting devices are essential where fixed guards are not practicable (for example, where the operator needs to feed blocks of stone into the cutting area), and operating controls are close to the knife.

A suitable guard should be fitted to the side of the guillotine opposite to the controls where workers may reach into the hazardous area. Guillotines which rely on someone picking or pushing the stone after being cut should be fitted with a drop side or conveyor. This is so the stone is fed away from the hazardous area. Alternatively, a suitable tool should be provided (see Figure 100).

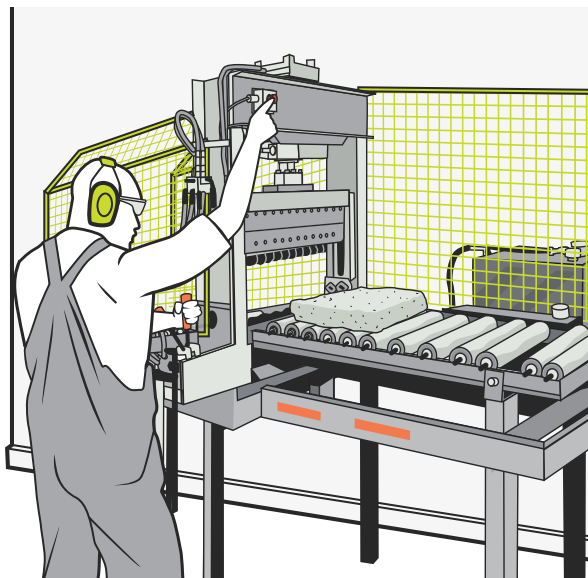

FIGURE 100:
Example of two-handed
starting device and
drop side extraction

Stone saw guarding

Stone saws range from sophisticated equipment capable of cutting large slabs of stone and intricate designs to smaller machines capable of simple cuts. Regardless of the size of the saw an operator may be close to the hazardous area when operating and suitable guarding or control measures should be in place.

For larger saws the use of perimeter fences and interlocked gates would prevent inadvertent access and prevent the operator from working too closely to the equipment.

Fixed guards alone might not be feasible as access is required for loading and unloading the stone. The following would all offer a high standard of protection:

A perimeter fence and interlocked guards, such as manually-actuated sliding access gates (see Figure 101). The interlocked guards should be fitted with a locking device, so the guard remains closed and locked until any risk of injury from the hazardous machine has passed. This should allow for the rundown time of the saw blade.

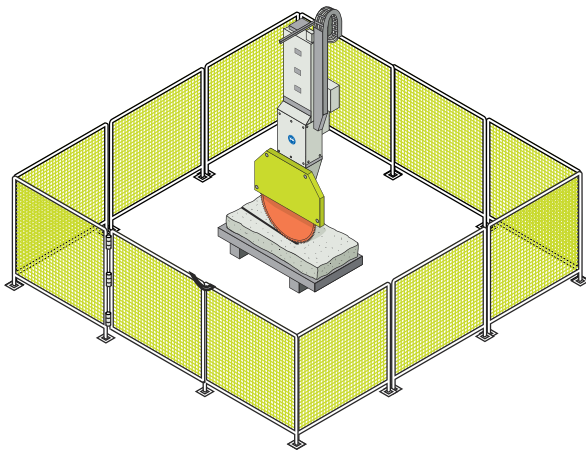

FIGURE 101:
Stone saw with
gate at access points

Electro-sensitive protective equipment such as light curtains at the front of the enclosure. When used in conjunction with a braking system to stop the movement before access to dangerous parts occurs. Alternatively, the saw head could immediately return to a home position with a local guarding enclosure (see Figure 102).

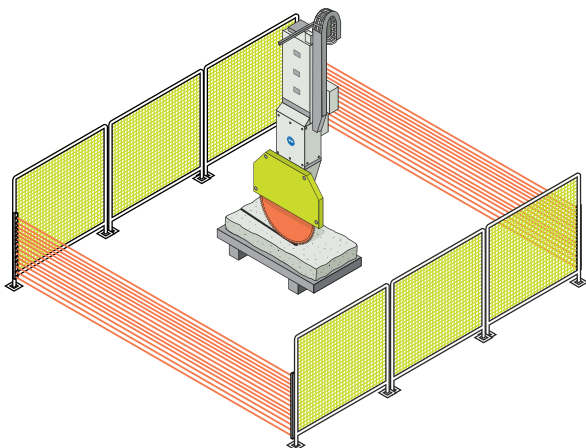

FIGURE 102:
Stone saw with light
curtains at access points

Local retracting guards around the circular saw blade and pressure sensitive edges on the saw head and traversing table. This would be in conjunction with fast stopping times of the head and saw blade.

Guards may be extended to serve as noise enclosures. Local exhaust ventilation systems may be integrated with the guard where appropriate.

Fixed guards or two-handed operator controls such as those outlined for stone guillotines may be suitable for smaller saws.

Remote-operator controls force the operator to remain at a safe distance from the hazard point (see Figure 103). Hold-to-run controls should be used for remote-operator controls. The machine should run down in the time it would take someone to reach the hazardous area when the operator removes their finger or hand from the control. Suitable controls should be in place to stop anyone else entering the hazardous area.

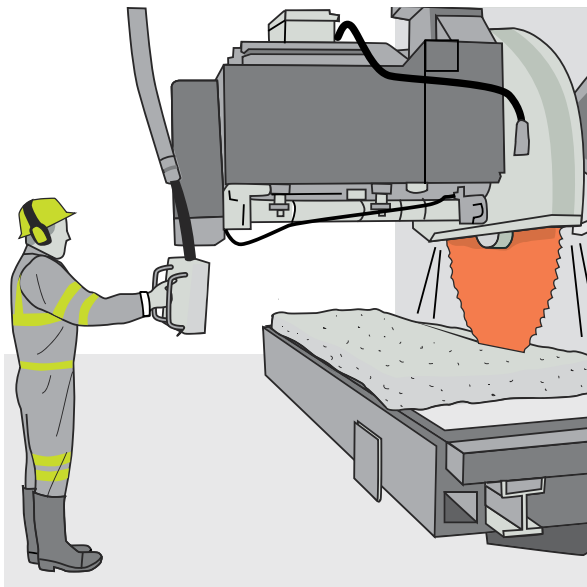

FIGURE 103:
Remote operation controls on stone saw

15.9 Guarding and maintenance

Where maintenance requires normal guarding to be removed, then additional measures will be needed to prevent danger from the mechanical, electrical and other hazards that may be exposed. This is also necessary if access is required inside existing guards. There should be clear company rules on what isolation procedures are required, and in what circumstances. For example, some cleaning of mixing machinery may require isolation, even though it might not be considered a maintenance task.

Tensioning, tracking, lubrication and other maintenance is usually done while equipment is running. To eliminate the risk of injury, rods and nuts should protrude out beyond the guards. Consider grouping the lubrication points for access outside the guards (see Figure 104). Consideration should be given to this when designing plant.

Consider manual handling when removing guards for maintenance to be carried out. Lifting attachments on guards may be required.

For more detailed information on lockout and tagout for maintenance and repairs, see Section 15.17.

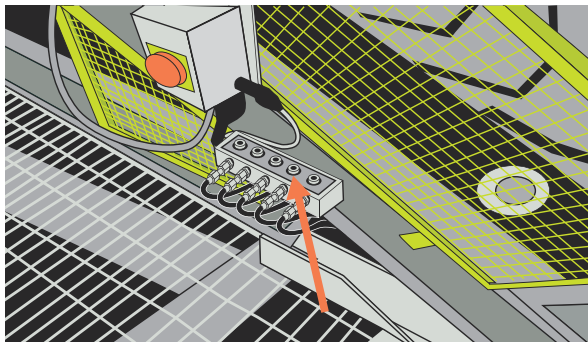

FIGURE 104:
Example of remote greasing points

15.10 Conveyors

Anti-run back device and controlled braking

Some inclined conveyors have the potential to either run back (where the direction of the material is up) or run away (where the direction of the material is down). These situations can be prevented by installing an anti-run back device (or sprag clutch) and controlled braking systems.

Standards for safety of machinery can add more information on anti-run back devices and controlled braking systems. See *AS/NZS 4024 Safety of Machinery – Part 3610: Conveyors – General Requirements* or *AS/NZS 4024 Safety of Machinery – Part 3611: Conveyors – Belt Conveyors for Bulk Materials Handling*.

Conveyor crossovers and underpasses

As well as the guarding requirements outlined in Section 15.8, you must provide safe crossing points where a conveyor may be crossed. Crossing over or under conveyors should be prohibited except where safe passageways are provided.

Access routes must maintain a minimum of 2.1m clearance overhead (as defined in the NZ Building Code – Clause D1: Access Routes). However, where people can reach into moving parts the clearance overhead should be a minimum of 2.7m in accordance with *AS/NZS 4024.1 Safety of machinery*.

The MOQO Regulations specify that an extractives operator must ensure any conveyor belts are:

- designed, installed and used in a way that will address any hazard that may arise when the conveyor belt is started
- fitted with an emergency stop system that can be activated at any point along the length of the conveyor belt accessible by any person
- designed, installed and used to protect any person near or travelling under a conveyor belt from being struck by fallen objects
- designed, installed and used to address the hazards arising from the interaction between people and the conveyor belt. This must include provision for the safe crossing of conveyor belts, where they may be crossed.

Whenever conveyors pass adjacent to, or over, work areas, roadways or other passageways, protective guards should be installed. The guards should be designed to catch and hold any load or material that may fall off or become dislodged from the conveyor (for more information on conveyor skirt boards see Section 15.8).

Where conveyors are operated in tunnels, pits and similar enclosures, ample room should be provided to allow safe access and operating space for all workers.

Pre-start warnings on conveyor belts

Pre-start warnings must be provided on conveyor belts to address any hazard when they are started.

On overland conveyor systems, the devices should be placed at the transfer, loading, and discharge points and those points where workers are normally stationed. Warning signs stating 'conveyor may start without warning' should be strategically placed along overland conveyors where it is reasonably foreseeable that people may gain access.

For more information on pre-start warning systems see Section 15.12.

Reclaim tunnels

The nature of reclaim tunnel operations means the presence of people in the tunnel is normally only required on an infrequent and irregular basis. Loading operations are usually remotely activated and control room operators may not expect workers to be in the reclaim tunnel which can lead to hazardous situations. Workers should only enter the reclaim tunnel to inspect, clean or maintain the system when effective safe systems of work are in place.

Reclaim tunnels may be a confined space entry (see Section 15.16).

15.11 Emergency stops

Emergency stops, including pull wire emergency stops, should not be used as a substitute for guards. They are an additional control measure. Emergency stops should be in red with a yellow background, where practical, and signs should be erected for easy identification (see Figure 105).

Do not use emergency stops to lock-out the plant or equipment because the actuators are part of the control circuit and not an isolation of the energy supply.

Emergency stops should:

- be prominent, clearly and durably marked
- be immediately accessible to each user of the plant or equipment
- have red handles, bars, push buttons or pull cords (labels can also be used)
- not be affected by electrical or electronic circuit failure.

Mine operators must fit an emergency stop system that can be activated at any accessible point along the length of a conveyor belt.

For more detailed information on emergency stop controls see our best practice guidelines [Safe Use of Machinery](#) (Section 8.1.7 of that guide) and for design refer to *AS/NZS 4024 Safety of Machinery: Part 1604: Design of controls, interlocks and guarding – Emergency stop – Principles for design*.



FIGURE 105:
Emergency stop
with signage

15.12 Pre-start warning systems

Pre-start warning systems are mandatory on conveyors. For other plant, pre-start warning systems should be provided on machinery where sudden, unexpected operation could cause serious or fatal injuries to those who may be close to the machinery. Consider systems with visual, acoustic and tactile signals.

Because mines and quarry processing areas can be noisy and spread out, consider both visual and acoustic prestart warnings that work in conjunction with one another.

Acoustic signals should:

- sound for long enough before the plant or equipment starts to provide adequate warning to anyone who may be in a position of risk
- loud enough so they can be heard in the area they are providing a warning for
- be at a level higher than the ambient noise without being excessive or painful
- be clearly different from any other warning signals or alarms.

Visual signals (such as flashing lights) should be placed so people close to the plant or equipment will have the best opportunity to see it. You may need multiple visual signals depending on the set-up of your plant and whether an acoustic signal will be sufficient to provide warning. Where visual signals are used, they should be of a suitable brightness and colour contrast to the background.

For more detailed information on acoustic and visual signals refer to *AS/NZS 4024 Part 1904: Design, controls, actuators and signals - Indication, marking and actuation*.

15.13 Electricity

The Electricity (Safety) Regulations 2010:

- state the generic rules and requirements about electrical safety and what is deemed to be electrically safe and unsafe
- deal with the design, construction and use of works, installations, fittings and appliances
- provide for installations to be designed and installed under *AS/NZS 3007 Electrical equipment in mines and quarries - Surface installations and associated processing plant*

- define certification and documentation required for all electrical works
- state requirements for periodic assessment and verification of electrical safety
- set out in schedules all the applicable standards, with a focus on the adoption of international standards
- define requirements relating to safety management systems
- provide for offences including infringement offences.

The Electricity (Safety) Regulations 2010 places requirements on the owners of mining electrical equipment to ensure it is electrically safe. The Regulations state the standards to use for certain installations, along with periodic assessment requirements for mobile and relocatable mining electrical equipment.

One particularly important document is *AS/NZS 3007:2013 Electrical equipment in mines and quarries – Surface installations and associated processing plant*. You should make sure all electricians working on your site are familiar with this standard.

Mobile and relocatable equipment at alluvial mines and quarries must be assessed at least yearly against *AS/NZS 3007* by a person authorised to inspect mining electrical equipment in accordance with the Regulation 78D of the Electrical (Safety) Regulations 2010.

As a general approach, you should:

- use residual current devices (RCDs)
- ensure equipment is correctly earthed
- electrical substations should be kept clean and not used as stores. They should be kept locked with access to authorised workers only
- all equipment, including electrical supply and accessories, should be part of the electrical maintenance and inspection scheme
- batteries should be treated with caution. Manufacturers' instructions should be followed for maintenance and precautions to be taken (for example, PPE)
- dust accumulations can have a serious effect on the safe functioning of electrical equipment. Make sure housekeeping procedures are in place
- all electrically powered equipment should be capable of being isolated. The isolation points should be clearly labelled and means of isolation provided
- operators should not have access to switchboards or enclosures that provide direct contact to an electrical hazard. Access to certain electrical equipment should be restricted with the use of a tool or key, and should be properly shrouded to prevent inadvertent access to exposed electrical conductors
- where the operators have been properly trained it may be appropriate to access some electrical equipment for the purposes of resetting trips. In these cases it may be permissible to open cabinet doors provided the equipment inside is properly shrouded to prevent inadvertent access or arc flash
- switchboards should be securely locked at all times. Where wiring is damaged it should be reported immediately. Water should not be allowed to accumulate in switch boards or switch rooms
- underground cables and pipes should be accurately located on a site plan and identified before digging.

For more detailed information on safety around underground cables and pipes see our good practice guidelines [Excavation safety](#)

Flexible cords

Flexible cords should have a current tag issued in accordance with *AS/NZS 3760:2022 In-service safety inspection and testing of electrical equipment and RCDs*. Minimum information a test tag should have is:

- a reference to being tested to *AS/NZ 3760*
- the test date
- the next test date due.

A flexible cable or cord (for supply purposes) is one that has one end connected to a plug with pins designed to engage with a socket outlet and the other end either:

- connected to terminals within the equipment, or
- fitted with a connector designed to engage with an appliance inlet fitted to the equipment.

Flexible cords are prone to damage because they are often outdoors in operational areas and can be subject to falling material, repetitive use, movement, vibration and extremes of weather. Regardless of the date of the tag, all flexible cords should be examined before being plugged in and used. Consider any shock or tingle as a warning of a potential safety problem. If this occurs, immediately switch off, isolate and remove the cable and do not use it again until tested by a competent electrician.

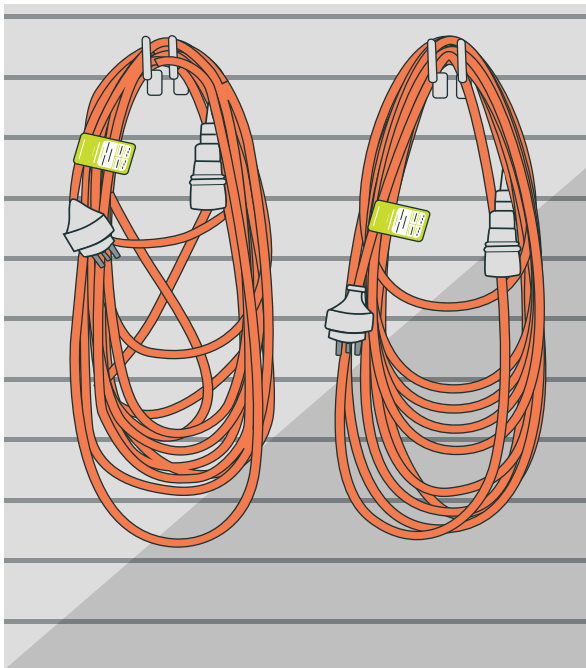

FIGURE 106:
Flexible cords with tags

Trailing cables

Safe systems of working with trailing cables should include meeting the New Zealand Electricity (Safety) Regulations 2010 and *AS/NZS 3007 Electrical equipment in mines and quarries – Surface installations and associated processing plant*.

These safe systems of working with trailing cables should also include:

- regular inspections including in-situ visual inspection by machine operators and regular documented safety assessments (at least annually) with documentation kept in a verification dossier for the equipment onsite
- route criteria including support measures (where applicable), methods and heights for crossings, location of cables in proximity to roadways, protection measures required where it is necessary for vehicle crossings

- methods for relocation of cables and provision of adequate equipment to perform the task such as cable reelers or relocators
- defined methods for manual handling and provision of adequate mechanical lifting aids to eliminate manual handling sprains and strains. Equipment to separate and join plugs should be sought
- regular inspection, maintenance and testing performed on substation earth systems including earth mats, earth impedance and earth connection points, protection relays and trip batteries
- provision of unique clear identifiers for each cable and trailing cable plug and substation outlet
- defined standards for the circumstances under which trailing cable protection relays can be reset and power re-energised onto a cable where the relay has indicated a fault to be present
- developing, implementing, monitoring and reviewed systems of high voltage switching, access and authorisation
- minimising direct handling of energised cables. Anyone required to directly handle energised trailing cables should wear insulating gloves covered by leather outer.

Training should be provided in the above and in trailing cable hazard awareness for all people required to work with them. Workers associated with relevant tasks should be consulted in relation to the development of the systems and standards mentioned above.

15.14 Cranes and lifting equipment

Where there is a crane on site, you must comply with the Health and Safety in Employment (Pressure Equipment, Cranes and Passenger Ropeways) Regulations 1999 and should comply with the [Approved Code of Practice for Cranes](#)

Fixed cranes include gantry cranes, overhead hoists, monorail systems, davit arms or fixed lifting points. The structures supporting the crane should be certified by a chartered professional engineer with respect to design, construction and non-destructive testing, as relevant.

The issued structure certificate should specify:

- design standards referenced
- maximum permissible safe working load and any load limitations or conditions
- details of equipment that may be used on the certified structure (**Note:** Some equipment is exempt from this requirement. Refer to the Notice of Exemption for Equipment under the Health and Safety in Employment (Pressure Equipment, Cranes, and Passenger Ropeways) Regulations 1999, New Zealand Gazette, No 188, page 4517, 17 December 2009).

Items of mobile plant, not originally designed as a crane used for load-lifting incidental to their principal function are exempt from the Health and Safety in Employment (Pressure Equipment, Cranes, and Passenger Ropeways) Regulations 1999 (Notice of Exemption for Equipment under the Health and Safety in Employment (Pressure Equipment, Cranes, and Passenger Ropeways) Regulations 1999, New Zealand Gazette, 24 September 2015) when the following conditions apply:

- Lifting points and equipment used for rigging loads are to be certified by a Chartered Professional Engineer, and

- In the case of hydraulic excavators with an operating weight of 12t or more the following additional conditions apply:
 - The equipment is not to be modified to make it operate as a crane other than the provision of a lifting point.
 - Hose burst protection valves are required.
 - Operators and ground support personnel are to be adequately trained as required by HSWA.
 - Operations are to be carried out in accordance with the Approved Code of Practice for Load-lifting – Rigging.
 - The equipment is to have a loading chart available to operators.

Sites using mobile plant for lifting should consider:

- planning for lifts with a lift plan completed by a suitably qualified operator, taking into consideration the rigging equipment and the full weight to be lifted
- using a dogman
- the orientation of the lifting plant in relation to the load
- assessing that the ground will take the loading of the excavator or other lifting plant
- checking that the ground loading does not create surcharges to trenches or batters
- using suitable lifting points (a strop slung over a fork on a forklift is not suitable).

All sites should develop a safe system of work for the use and management of all lifting equipment in accordance with the [Approved Code of Practice for Load-lifting Rigging](#)

This includes, but is not limited to:

- making sure every lifting appliance and item of loose gear is clearly and permanently marked with its ‘working load limit’ (WLL) by stamping, or where this is impracticable or not recommended, by other suitable means. Also, a unique identifying numbering system to clearly identify individual items should be used
- visual inspection prior to and after use
- examination by a competent person regularly depending on frequency, use, and environmental conditions but not exceeding 12 months
- a register should be kept for lifting equipment. The register should show the date of the last recorded examination or test, and any alterations.

15.15 Maintenance of plant and structures

Tasks such as maintenance, repairs, servicing, clearing blockages and cleaning can be dangerous. Workers can be fatally or seriously injured if they do not manage the risks carefully.

You should establish a maintenance and inspection programme to ensure equipment and machinery is safe to use. Maintenance and inspection programmes should take into account:

- the operational environment the machinery or vehicles are being used in, particularly where subject to corrosion or rot
- the original equipment manufacturer’s recommendations.

Maintenance and inspection programmes should take into account the whole of the machinery or vehicles including, as appropriate, including:

- the structure of the machinery (bracing or supports)
- safety features (such as emergency stops, guarding, emergency equipment or props)
- integrity of walkways, stairs, ladders, railings or guardrails
- integrity of holding vessels (for example, tanks or hoppers)
- integrity of lifting equipment (for example, chains, strops, hooks, gantry cranes, lifting eyes or quick hitches)
- signage and other warning devices (such as lights or alarms).

All extractives operators must ensure a competent person examines any mobile plant that has been stopped for the preceding 24 hours or longer before it is started. In addition, the extractives operator must ensure a competent person examines every accessible area of the operation.

Inspect every area containing barriers, machinery and surface infrastructure at least weekly and every area where a worker, is or will be, before every shift and during shifts as required.

A written procedure must be included in the health and safety management system setting out:

- what will be examined
- when it will be examined
- how findings will be recorded
- how findings will be actioned.

For more detailed information on inspection and maintenance of machinery, including safe systems of work, see our best practice guidelines [Safe use of Machinery](#)

15.16 Common hazards when undertaking maintenance

Undertaking maintenance activities (including cleaning) can potentially expose workers (and others) to significant hazards. The hazards outlined in the following chapters merit particular attention:

Falls from height

Maintenance work often involves using access equipment to reach raised sections of machinery or vehicles. Eliminating the need to access machinery or vehicles at height by careful design is the most effective control.

Where elimination is not practicable, and frequent access is required, then platforms, walkways, stairways and ladders that comply with the Building Code should be provided. Where infrequent access is required, suitable temporary access equipment with adequate barriers or fall restraint systems should be used.

For more detailed information on platforms, walkways, stairways and ladders see the Compliance Document for New Zealand Building Code Clause D1 Access Routes and Compliance Document for New Zealand Building Code Clause F4 Safety from Falling.

More information on the hazards of working at height can be found in our [Best practice guidelines for working at height in New Zealand](#)

Portable ladders

Portable ladders should be used for low-risk and short-duration tasks. The user should maintain three points of contact with a ladder or stepladder to reduce the likelihood of slipping and falling. Ladders and stepladders do not offer fall protection and should therefore be the last form of work access equipment you consider.

Portable ladders should comply with *AS/NZS 1892.1 Portable ladders – Metal* or any other standard embodying the same or more stringent criteria.

All portable ladders should have their safe working load certified by the manufacturer and be inspected for any damage prior to every use.

For more information on ladders and stepladders see our [Best Practice Guidelines for Working at Height in New Zealand](#)

Falls of heavy items

Heavy items sometimes have to be moved, or get disturbed, during maintenance work. If one of these falls, the results can be fatal.

Incidents can include:

- the failure of lifting equipment
- inappropriate lifting and slinging practices
- inadequate supports or supports not resting on level or firm ground
- incorrectly estimating the weight or centre of gravity of the load
- rocks falling from trap points on mobile plant or the headboards of haul trucks.

If a heavy item has to be moved or temporarily supported during maintenance work, it is crucial to assess the risks and properly think through a plan of action. The people responsible for the maintenance work should not presume that things will be okay, that others will know what to do, or the right equipment will necessarily be available. These lifts, or the use of temporary supports may be 'one offs' and will inevitably require more knowledge and skill than routine production tasks.

You should make sure:

- everyone involved in maintenance understands the risks
- an assessment of the risks (including the risk of disturbing something inadvertently) is completed and a plan of action decided on, before a heavy item is moved or temporarily supported
- there is someone competent to provide advice on safe slinging and on safe working practices for work involving heavy loads
- any equipment used to lift or support a heavy load is suitable and (where necessary) has been inspected and tested by a competent person
- heavy items are not left unsecured where they may tip over, fall or slip, and no-one works under suspended loads
- equipment is thoroughly cleaned with any loose material removed before maintenance activities commence.

Stored energy and energy sources

Isolation and lockout arrangements are essential to enable maintenance work to be conducted safely.

Before any maintenance work is undertaken you should:

- isolate the power or energy source (usually, but not exclusively, electrical energy)
- apply an isolation device and a sign to indicate that maintenance work is in progress
- dissipate any stored energy (such as hydraulic or pneumatic power)
- test and verify isolation is correctly applied.

For more information on isolation and lockout systems, see Section 15.17.

Confined space entry

A 'confined space' is:

- an enclosed or partially enclosed space and
- not intended or designed primarily for human occupancy
- may present a risk from one or more of the following at any time:
 - unsafe concentration of harmful airborne contaminants
 - unsafe concentration of flammable substances
 - unsafe levels of oxygen
 - substances that can cause engulfment.

These confined spaces can include tanks, load out bins, reclaim tunnels, crushers and poorly ventilated rooms.

People have died when entering confined spaces to carry out work. In some cases, multiple fatalities occur when would-be rescuers enter the space and become victims themselves.

You should minimise the time that tasks are undertaken in the confined space. This may be achieved by partially dismantling machinery or undertaking work outside the confined space before entry.

Where confined space entry is required, WorkSafe accepts the standard *AS/NZS 2865 Safe working in a confined space* as the current state of knowledge on confined space entry work.

For more detailed information see our quick guide [Confined spaces: planning entry and working safely in a confined space](#)

Welding and gas cutting

Welding can have acute, chronic and long-term hazards to health and safety. These can act quickly or may show up only in the long term.

Oxygen under pressure and oil or grease can react violently, causing fire and explosions. Do not allow oxygen under pressure to come into contact with oil or grease.

Welding hazards include:

- **Fires and explosions:** These are an ever-present hazard with many welding processes.
- **Burns:** Welding causes items to become hot, creating a risk of burns and fires from hot metal and welding spatter.
- **Fumes:** Fumes generated by different welding processes may range from being of nuisance to being highly toxic. Health effects can occur very soon after exposure (for example, exposure to cadmium fumes can be fatal within hours) or may not show up for many years. Fume control requires appropriate ventilation equipment and may require advice from a specialist.

- **Electric shock:** Welding processes that use electricity pose both obvious and subtle hazards of electric shock – which can be fatal. Take precautions, as explained in our guide [Health and Safety in Welding](#) when using welding equipment. Expert assistance can be needed in some circumstances to identify subtle hazards. Appropriate equipment selection, set-up and maintenance is important and may require specialist advice to ensure safety.
- **Compressed gases:** Compressed gases in cylinders pose a number of hazards.
- **Hazardous substances:** Hazardous substances used during some welding processes can require highly specialised methods of control (such as extremely toxic hydrofluoric acid). Use a specialist in these situations.
- **Toxic gases:** Precautions for preventing toxic gases from causing harm are outlined in our guide [Health and Safety in Welding](#). Toxic gases may be:
 - used in or generated by the process (for example, acetylene, ozone, nitrogen oxides and carbon monoxide)
 - generated when coatings on metal surfaces are heated (for example, galvanised steel, epoxy resins, degreasing agents or paint)
 - generated when the arc flash and some degreasing chemicals or paints react (such as phosgene or phosphine).
- **Suffocation:** Inert gases used during welding can flood an area and lower its oxygen content, especially in confined spaces. Suffocation can result. For more detailed information on confined space entry, see Section 15.16.
- **Radiation:** Arc flash is a well-known hazard of welding. Standard precautions (such as PPE) should be used to prevent eye and skin exposure, both for the worker and others in the vicinity. Reflecting surfaces make exposure to radiation more likely. For more information on PPE requirements see our guide [Health and Safety in Welding](#).
- **Heat stress:** Working for long periods in hot environments can lead to distress and, in extreme cases, to fatal heat stroke. Specialist advice must be sought if welders work in hot environments.
- **Dust:** Associated processes (grinding) may generate hazardous levels of dust.
- **Noise and vibration:** Noise and vibration levels during some welding processes can be high and should be controlled or appropriate hearing protection should be worn.
- **Manual handling:** Some welding processes may involve heavy or repetitive handling.
- Specific processes, including:
 - plasma cutting
 - brazing and soldering
 - thermal lancing.

For more information on hazards relating to worker health, see Section 4.

Providing health and safety information and advice on welding and cutting processes can be complex. There are many subtleties and traps for the unwary or inexperienced. Specialist advice may be required.

For more information on managing welding hazards, see our good practice guidelines for [Health and Safety in Welding](#)

In addition, the WorkSafe website has toolbox items to help raise awareness of the health risks from welding.

Clearing blocked crushers or hoppers

Clearing blocked crushers or hoppers can be very hazardous and plant operators have been killed carrying out this task. Blockage incidents can be greatly reduced by supplying material that is sized to match the primary opening.

Prevention of oversize feed material starts at the face, with good fragmentation. Removing oversize material before delivery to the plant and vigilant control of the crusher feeder, will make blockages less likely.

Causes of crusher blockages can be grouped under two main headings:

Stalling, due to:

- electrical or mechanical failure
- material jammed in the chamber causing an overload
- overfeeding material
- entry of tramp metal or wood
- accumulation of material in the crash box
- accumulation of fine material in the crusher discharge chute.

Bridging, due to:

- oversize feed material
- excessive clay or other fines in the crushing cavity, preventing small material passing through the crusher
- a foreign body in the crusher feed or discharge chamber, obstructing the feed material.

Prevention of blockages in crushers or hoppers

You should make every effort to prevent oversize material or tramp metal entering the crusher feed hopper by:

- designing any site blast to achieve optimum rock fragmentation
- training and instructing the loader driver not to load oversize material
- using sizing bars or grids on crusher feeds
- following the manufacturer's recommendations on the rate, presentation of feed and crusher settings
- instituting a programme of good housekeeping to prevent scrap steel entering shovel buckets
- ensuring the bucket size is appropriate to the capacity of the crusher
- regular inspection of metal parts (such as bucket teeth, dumper wear plates and drilling components) to make sure they are unlikely to break off and enter the crusher feed
- the strategic placing of electrical magnets or the installation of metal detectors to prevent tramp metal from entering the crusher
- the use of level indicators for feed control
- maintenance of drive systems
- removal and adequate cleaning of the discharge chute.

A properly designed crushing operation should not need any person to be present on the crusher access platform during normal crushing operations.

Clearing blockages in crushers or hoppers

BRIDGED CRUSHERS

The preferred method of clearing a bridged crusher is by using a hydraulic arm. The hydraulic arm may be permanently mounted, or an excavator fitted with a static pick or a hydraulic hammer. Where the arm is operated remotely (for example, by radio control) CCTV is an invaluable tool in assisting the operator.

When hydraulic arms are not available, and it is necessary for a worker to enter the crusher to position hooks or slings, the crusher and feeder must be stopped, isolated and locked out in accordance with the manufacturer's or supplier's instructions and safe working practices.

Other options (which require more specialist expertise and competence) include gas or chemical expansion and hydraulic ramp plates. Consider other options subject to a detailed and thorough risk assessment.

The crusher should be shut off and isolated before considering the use of bars and hand hammers. Bars should never be used on or near a crusher while it is running.

Consider the risk of large pieces of feed material moving and causing trap or crush injuries.

Do not use wedges due to the risk of them becoming a projectile (this has caused fatalities in the past).

STALLED CRUSHERS

A stalled crusher should be treated as possibly being jammed with tramp metal or wood, which could be ejected with fatal consequences. Safe systems of work should be issued to plant operators detailing what to do in the event of a crusher stalling which should include:

- clearing the area of all workers
- notifying the site manager of the stalled crusher
- isolating power to the crusher and associated plant
- undertaking a risk assessment for clearing the blockage
- implementing hazard control measures.

CLEARING BLOCKED CONE CRUSHERS

Many cone crushers are fitted (or can be retrofitted) with tramp metal hydraulic release systems or hydraulic assisted upper concave removal, to prevent or eliminate hazards associated with blocked cone crushers.

For cone crushers that do not have these systems, follow the guidelines above.

HAZARD OF ENTRAPMENT AT HOPPERS

There is the potential for an accident if anyone attempts to walk on the material that has been dumped into a hopper. The hazards are that they may be drawn into the feeding material, or, if the material is hung up, they may be drawn in when the material breaks free. The material in the hopper may look solid, but there may be a hidden void where it has bridged over the feeder. Anyone walking on the material is at risk of being engulfed if the bridged-over material collapses.

Mechanical devices should be provided (such as vibrators or air cannons) during normal operations so people are not required to enter or work where they are exposed to entrapment by the caving or sliding of materials.

Where people are required to enter or work near the hopper:

- provide platforms or staging
- stop supply and discharge of material
- lock and tag out equipment
- implement working at height procedures as required.

15.17 Lockout and tagout processes

Energy isolation is much more than putting a lock and tag on a switch. To effectively isolate workers from energy, you need to know what the energy is, and how it can be safely isolated on specific machinery and vehicles.

Lockout and tagout (LOTO) systems are the placement of a lock and tag on an energy-isolating device. They indicate that the energy-isolated device is not to be operated until removal of the lock and tag in accordance with an established procedure.

Lockout is the isolation of energy from the system (a machine, equipment or process) which physically locks the system in a safe mode. The locking device (or lockout device) can be any device that has the ability to secure the energy-isolating device in a safe position (such as lock and hasp).

Tagout is the labelling process that is used when lockout is required. The process of tagging-out a system involves attaching or using an indicator (usually a standardised label) that indicates:

- why the lockout and tagout is required (for example, during repair or maintenance)
- the date and time the lock and tag were attached
- the name of the authorised person who attached the lock and tag to the system.

Only the authorised person who put the lock and tag onto the system is allowed to remove them. This procedure helps to ensure the system cannot be started up without the authorised person's knowledge.

Safety devices such as guards or guarding devices are installed on systems to maintain worker safety while these systems are being operated. When performing non-routine activities these safety devices may be removed but there must be alternative methods in place to protect workers from the increased risk of injury of exposure to the accidental release of energy. Non-routine activities include maintenance, repair, set-up, or the removal of jams or misaligned feeds.

The main method used and recommended to protect workers from risk of harm in these cases is the use of a lockout and tagout procedure.

A lockout and tagout procedure will prevent:

- contact with a hazard while performing tasks that require removal, by-pass, or deactivation of safeguarding devices
- unintended release of hazardous energy (stored energy)
- unintended start-up or motion of machinery, equipment or processes.

LOCKOUT PROCEDURES AND WORK INSTRUCTIONS

The written lockout procedure should identify:

- what needs to be done
- when it needs to be done
- the tools available to do it
- who is supposed to do it
- who needs to be notified.

Work instructions should identify how the lockout process is to be carried out in a step-by-step process including how stored energy is controlled and de-energised, how isolation can be verified, and how and where lockout devices are installed. Work instructions should be machine, equipment or process specific and include pictures or images of what is being described.

There should be one lockout procedure, and as many sets of work instructions as required, depending on the number of systems that require lockout.

For more information on how to use lockouts to safely isolate and de-energise the parts of machinery that could cause harm to workers when servicing this machinery, see our quick guide [Keeping workers safe when servicing machinery](#)

15.18 Permit to work systems

A Permit to Work (PTW) system is a formal documented process used to manage work identified as significantly hazardous by making sure all safety measures are in place before work starts.

A PTW system is also a way to communicate between site management, plant supervisors, operators and those who carry out the hazardous work.

Essential features of a PTW system are:

- clear identification of who may authorise particular jobs (and any limits to their authority) and who is responsible for specifying the necessary precautions
- training and instruction in the issue, use and closure of permits
- monitoring and auditing to make sure the system works as intended
- clear identification of the types of work considered hazardous
- clear and standardised identification of tasks, risk assessments, permitted task duration and supplemental or simultaneous activity and control measures.

The terms 'permit to work', 'permit' or 'work permit' refer to the paper or electronic certificate or form used to authorise certain people to carry out specific work at a specific site at a certain time. It also sets out the main precautions needed to complete the job safely.

When are permit to work systems required?

Consider permit to work systems whenever the intention is to carry out particularly hazardous work. PTW systems should not be applied to all activities, as experience has shown their overall effectiveness may be weakened. Permits to work are not normally required for controlling general visitors to site or routine maintenance tasks in non-hazardous areas.

Permit to work systems are normally considered most appropriate to:

- non-production work (for example, intrusive maintenance, repair, inspection, testing, alteration, construction, dismantling, adaptation, modification or cleaning)
- non-routine operations
- jobs where two or more individuals or groups need to coordinate activities to complete the job safely
- jobs where there is a transfer of work and responsibilities from one group to another (such as shift changeovers).

Specially, you could consider permits for:

- work of any type where heat is used or generated (such as by welding, flame cutting, grinding) and work which may generate sparks or other sources of ignition
- work which may involve breaking containment of a flammable, toxic or other dangerous substance or pressure system, and work involving the use of hazardous or dangerous substances, including explosives
- work on high voltage electrical equipment or other electrical equipment which may give rise to danger
- entry and work within confined spaces
- pressure testing
- work affecting evacuation, escape or rescue systems
- work at height
- any other potentially high-risk operation.

EXAMPLE OF A PERMIT TO WORK (PTW) SYSTEM

Step 1: Highlight Potential Hazards	Workers guided by the supervisor identify potential hazards and implement all necessary safety measures according to the PTW requirements. Work is not permitted to start until step 4.
Step 2: Application for Permit	The Supervisor (or permit receiver) applies for permission to start work on a prescribed form. The supervisor then submits the application of the PTW to the authorised person (or permit issuer) only when all the conditions in the PTW have been fulfilled. The receiver has to indicate in the PTW that risk assessment was conducted for the task and the safety measures to be implemented.
Step 3: Evaluation of Permit	The permit issuer evaluates and verifies that all safety conditions specified in the PTW have been fulfilled and adequate. They may also recommend additional measures in the PTW when necessary. They need to inspect the work location where the PTW has been applied for with the receiver during this process. Only when all safety requirements stated in the PTW are fulfilled, will the permit issuer endorse the PTW form and, if required, forward the permit to the authorised manager. Note: Some companies require an authorised manager to approve work where the initial risk score is at a certain level. For example, the task has been risk scored in the high or extreme category. If this system is not used, steps 3 and 4 may be done by the permit issuer.
Step 4: Approval of Permit	The authorised manager (or permit issuer) may approve and issue the PTW only when they are satisfied that: <ul style="list-style-type: none"> - proper evaluation of risk and hazards for the work concerned has been conducted - no incompatible work will be carried out at the same time and location of the PTW, which may pose a risk to the people at work - all reasonably practicable safety measures have been taken and all people involved in the work have been informed of the work hazards under the PTW. <p>Work is permitted to commence on issue or approval of the PTW. The supervisor then posts a copy of the PTW at work location stated in the PTW. The copy will not be removed from the work location until the duration of the PTW has expired or work stated in the PTW has been completed.</p> <p>Note: Permit receivers and permit issuers should not be the same person.</p>

TABLE 13: Example of a Permit to Work (PTW) system

Appendices

IN THIS SECTION:

Appendix A: Glossary

Appendix B: References

Appendix C: Health and Safety at Work Act 2015 duties

Appendix D: So far as is reasonably practicable (section 22 of HSWA)

Appendix E: Working with other PCBUs – overlapping duties
(section 34 of HSWA)

Appendix F: Worker engagement, participation and representation
(Part 3 of HSWA)

Appendix G: Upstream duties (sections 39–43 of HSWA)

Appendix A: Glossary

TERM	DEFINITION
A-grade operation	Extractive operations with more than four workers.
Alluvial mine operator	Is a person who controls an alluvial mining operation and, in relation to a particular alluvial mining operation, means the person who controls that operation.
Alluvial mining operation	A mining operation carried out above ground and associated with: <ul style="list-style-type: none"> - the extraction of gold from river deposits of sand or gravel - the extraction of ironsand from sand or gravel.
ANFO	An explosive material consisting of ammonium nitrate and fuel oil.
Angle of repose	The angle of repose is the angle at which the material rests when simply dumped in a pile. This angle will vary somewhat depending on the size and shape of the constituent particles, how the material is dumped (for example how far it is dropped) and the amount of moisture in the material when it is dumped.
Authorised person (for LOTO)	Is an individual who is qualified to control hazardous energy sources because of their knowledge, training and experience and has been given authority to apply LOTO.
B-grade operation	Extractive operations with four or fewer workers.
Back-break	Rock broken beyond the limits of the last row of holes in a blast.
Batter	The portion of a slope between benches.
Benching	A safety feature to catch any rocks or reeling material that falls from the high walls above. A horizontal ledge from which holes are drilled vertically down into the material to be blasted. Benching is a process of excavating where a slope is worked in steps or lifts.
Certified handler	A person who holds a compliance certificate that certifies that the person meets the competency requirements for certified handlers specified in Regulation 4.3 of the Hazardous Substances Regulations.
Competent person	A person who has the knowledge, experience, skills, and qualifications to carry out a particular task under the MOQO Regulations and has a relevant qualification or certificate issued by their employer showing this.
Confined space	A place which is substantially (though not always entirely) enclosed, and where there is a risk of death or serious injury from hazardous substances or dangerous conditions (such as lack of oxygen). These can include storage tanks, silos, reaction vessels, enclosed drains and sewers, open topped chambers, ductwork and poorly ventilated rooms.
Control measure	A control measure is a way to eliminate or minimise (reduce) a risk to health and safety.
Crest	The top edge of a slope or batter where the ground levels out.
Dam	Has the meaning given in section 7 of the Building Act 2004 being: “dam: a. means an artificial barrier, and its appurtenant structures, that: i. is constructed to hold back water or other fluid under constant pressure so as to form a reservoir, and ii. is used for the storage, control, or diversion of water or other fluid, and b. includes: i. a flood control dam, and ii. a natural feature that has been significantly modified to function as a dam, and iii. a canal, but c. does not include a stopbank designed to control floodwaters”.
DBT	Dynamic brake testing.
De-energisation	The process used to disconnect and isolate a system from a source of energy in order to prevent the release of that energy. By de-energising the system, you are eliminating the chance the system could inadvertently, accidentally or unintentionally cause harm to a person through movement, or the release of heat, light or sound.

TERM	DEFINITION
Duty	<p>A duty is a legal requirement that must be met. Under HSWA, there are four groups with health and safety duties:</p> <ul style="list-style-type: none"> - persons conducting a business or undertaking (PCBUs) - officers - workers - other persons at the workplace. <p>See Section 30 of HSWA</p>
EDM	<p>Electronic distance measurement or electro-optic distance measuring. Used for geodetic surveys.</p>
Eliminate	<p>To eliminate a risk means removing the hazard (the source of harm).</p> <p>For more information see How to manage work risks</p>
Emergency drill	<p>A process of testing training, relating to emergency events, which is repeated from time to time.</p>
Emergency	<p>An unplanned event that is not controlled where there is a threat to life or the health and safety of people at or outside the operation.</p>
Engagement, participation, and representation	<p>A key part of health and safety involves PCBUs and workers working together.</p> <p>There are three parts to this:</p> <ul style="list-style-type: none"> - PCBUs talking with workers about health and safety (engagement) - workers being able to raise health and safety concerns and suggest improvements (participation) - workers being represented on health and safety matters. This could be by a Health and Safety Representative (HSR), a worker's union, or a person that workers authorise to represent them (for example a kaumātua, or community or church leader) (representation). <p>For more information see Good practice for worker engagement, participation and representation</p>
Face	<p>The surface where extraction is advancing. May also be referred to as pit face or working face.</p>
FOPS	<p>Falling object protective structure. Protection for the driver and any passengers in a vehicle from falling objects.</p>
FRAS	<p>Fire resistant anti-static.</p>
Freeboard (for dams)	<p>The distance between normal reservoir level and the top of the dam.</p>
Freeboard (for vessels)	<p>The distance between the waterline and the main deck or weather deck of a ship or between the level of the water and the upper edge of the side of a small boat.</p>
Haul vehicles	<p>Vehicles used to haul product or material from the place of extraction to the processing plant, stockpile or tip.</p>
Hazard and risk	<p>A hazard is something that could cause harm. It could be an object, activity, event or even a person's behaviour.</p> <p>Risks to health and safety occur from people being exposed to hazards. Risk has two components - the likelihood that it will occur and the consequences (degree of harm) if it happens.</p> <p>For more information see How to manage work risks</p>

TERM	DEFINITION
Hazardous substance	<p>Hazardous substances are, unless expressly provided otherwise by regulations or an EPA notice, any substance with one or more of the following intrinsic properties:</p> <ul style="list-style-type: none"> - explosiveness - flammability - a capacity to oxidise - corrosiveness - toxicity (including chronic toxicity) - ecotoxicity (with or without bioaccumulation), or - which on contact with air or water (other than air or water where the temperature or pressure has been artificially increased or decreased) generates a substance with any one or more of the properties specified in the Hazardous Substances and New Organisms Act 1996.
Health and Safety at Work Act 2015 (HSWA)	<p>The Health and Safety at Work Act is the key work health and safety law in New Zealand. It is often shortened to 'HSWA'.</p>
Health and safety inspector	<p>A person employed by WorkSafe (or Civil Aviation Authority or Maritime New Zealand) to assess health and safety compliance and investigate work health and safety incidents. Inspectors have a range of powers under health and safety laws, including being able to enter and inspect a workplace, to require answers to specific questions, and to seize items for use as evidence.</p>
Heavy vehicles	<p>Includes haul trucks, loaders, scrapers, dozers, water trucks, graders, low loaders, cable reelers, draglines, shovels, backhoes, drills and similar equipment. Heavy vehicles are those that transport or extract materials, overburden or reject material.</p>
Hierarchy of control measures	<p>Using the hierarchy of control measures is a way PCBUs can manage health and safety risks.</p> <p>Following this approach, PCBUs first consider if the most effective control measures can be put in place before considering less effective ones.</p> <p>The first step is to try to eliminate a risk by removing the hazard. If a risk cannot be eliminated, the next step is to minimise the risk. This involves first trying to:</p> <ul style="list-style-type: none"> - substitute by swapping with something that has a lower risk - isolate by separating people from the source of harm - apply engineering control measures by changing physical components of the plant, structure or work area. <p>If there is still risk, put in place administrative control measures – using safe methods of work, procedures or processes.</p> <p>The last step involves personal protective equipment (PPE) – using or wearing items (including clothing) to minimise risks to personal health and safety.</p> <p>For more information see How to manage work risks</p>
Inter-ramp slope	<p>A succession of batters between two access ramp sections (or between a ramp section and floor or crest).</p>
Intrusive maintenance	<p>Maintenance that requires interruption to the process. It usually requires shutdown, isolation of hazardous energy, LOTO, opening or disassembly.</p>
Large dam	<p>Has the meaning given in section 7 of the Building Act 2004 being: “large dam means a dam that has a height of 4 or more metres and holds 20,000 or more cubic metres volume of water or other fluid”.</p>
Light vehicles	<p>Includes wheel mounted light and medium duty vehicles of various sizes which are primarily used in the transportation of people, supplies, tools and fuel or lubricants. They include but are not limited to lube trucks, utes, SUVs, vans used as worker transporters, tyre mounted cranes, and forklifts, and so on.</p>
LOTO	<p>Lockout and Tagout.</p> <p>Lockout and tagout systems are the placement of a lock and tag on an energy-isolating device.</p>

TERM	DEFINITION
Mineral	A naturally occurring inorganic substance beneath or at the surface of the earth, that: <ul style="list-style-type: none"> - includes metallic minerals, non-metallic minerals, and precious stones, and - does not include clay, coal, gravel, limestone, sand or stone.
Minimise	To minimise (reduce) a risk means to: <ul style="list-style-type: none"> - reduce how serious the consequences are if it does occur or if a worker is exposed to the hazard (source of harm) - reduce the chances of it occurring or a worker being exposed to the hazard. <p>For more information see How to manage work risks</p>
Mining operation	A mining operation: <ol style="list-style-type: none"> a. means the extraction of coal and minerals and the place at which the extraction is carried out; and b. includes any of the following activities and the place at which they are carried out: <ol style="list-style-type: none"> i. exploring for coal ii. mining for coal or minerals iii. processing coal or minerals associated with a mine iv. producing or maintaining tailings, spoil heaps, and waste dumps v. the excavation, removal, handling, transport, and storage of coal, minerals, substances, contaminants, and wastes at the place where the activities described in subparagraphs (i) to (iv) are carried out vi. the construction, operation, maintenance, and removal of plant and buildings at the place where the activities described in subparagraphs (i) to (iv) are carried out vii. preparatory, maintenance, and repair activities associated with the activities described in subparagraphs (i) to (iv); and c. includes: <ol style="list-style-type: none"> i. a tourist mining operation ii. a tunnelling operation; but d. does not include: <ol style="list-style-type: none"> i. exploring for minerals ii. an alluvial mining operation iii. a mining operation wholly on or under the seabed on the seaward side of the mean high-water mark iv. a quarrying operation.
Mine operator	The responsible person for a tourist mining operation, suspended mining operation or a coal exploration operation.
Misfire	When a blast does not fire correctly, or one or more blast holes do not fire.
Mobile plant	Plant that is capable of moving: <ul style="list-style-type: none"> - under its own power while energised by an internal power source, for example a battery, compressed air, or an internal combustion engine - while energised by a reeling cable or trailing cable.
Monitor	To check, supervise, observe or record the progress of an activity or procedure regularly in order to make sure it is being carried out.
MOSS	Maritime Operator Safety System.
MPU	Mobile processing unit. Purpose-built vehicles that delivers and manufactures bulk explosives directly into a blasthole.
Must	When 'must' is used in these guidelines, it means a legal requirement that must be complied with.
Near miss	An event that has the potential to cause injury or illness if circumstances, such as the interval of time of the event, were different.

TERM	DEFINITION
Notifiable event	<p>WorkSafe must be told when certain things occur that are related to the work you do. These are called notifiable events. There are three kinds of notifiable events:</p> <ul style="list-style-type: none"> - deaths - certain injuries or illnesses (called notifiable injuries or illnesses) - certain incidents (called notifiable incidents). <p>For more information see How to manage work risks</p>
OEM	Original equipment manufacturer.
Officer	<p>An officer is someone who has a specified position (like a company director).</p> <p>An officer is also someone who has a strong influence over how a business or undertaking is run. An example is a Chief Executive. Officers have health and safety duties.</p> <p>For more information see Officer duties</p>
Opencast coal mining operation	Any mining operation associated with the exploration or extraction of coal and where no person works underground.
Opencast metalliferous mining operation	Any mining operation associated with the extraction of minerals and where no person works underground.
Other persons at the workplace	<p>'Other persons at the workplace' is the term used to describe the people at a workplace who are not workers. This includes:</p> <ul style="list-style-type: none"> - customers or clients - visitors - passers-by - casual volunteers (not volunteer workers). <p>Like workers, these people have health and safety duties. For more information see Other persons at the workplace</p>
Overall slope	The full height of a slope from the toe to the crest which may comprise several batters separated by benches.
Overburden (mines)	In mining overburden (also called waste or spoil) is the material that lies above an area of economic interest. It is most commonly the rock, soil, and vegetation above a coal seam or ore body.
Overburden (quarries)	In quarrying overburden is the material that lies above the intended quarry site. It is most commonly the top-soil, sub-soil and vegetation.
Overlapping duties	<p>Overlapping duties is the term WorkSafe uses to describe when a PCBU shares duties with other PCBUs.</p> <p>Overlapping duties can occur in a shared workplace (for example, a building site or a port) where more than one business and its workers control and influence the work on site.</p> <p>Also, PCBUs do not need to be at the same worksite to have overlapping duties. For example, overlapping duties can also occur in a contracting chain, where contractors and subcontractors provide services to a head contractor or client.</p> <p>For more information see Overlapping duties - quick guide</p>
OVM	Original vehicle manufacturer.
PCBU	<p>'Person conducting a business or undertaking' is a term used to cover all types of working arrangements.</p> <p>PCBUs can range from businesses (large corporates, small-medium companies, partnerships, sole traders) to non-commercial organisations (like not-for-profit groups).</p> <p>PCBUs have many health and safety duties.</p> <p>Certain people/organisations are not PCBUs - including certain types of volunteer organisations.</p> <p>For more information see Who or what is a PCBU?</p>

TERM	DEFINITION
PPE	<p>Personal protective equipment are items used or worn by someone to reduce risks to their health or safety.</p> <p>For more information see Personal protective equipment (PPE)</p>
PFD	<p>Personal flotation device. Typically a lifejacket, life vest, life preserver, buoyancy vest or buoyancy aid.</p>
PHMP	<p>Principal Hazard Management Plan</p>
Plant	<p>Defined in HSWA as any machinery, vehicle, vessel, equipment, appliance, container, implement or tool, as well as any component of those things or anything fitted to those things.</p>
Powder factor	<p>The amount of explosive used per unit of rock. Also called Explosive Loading Factor.</p>
Pre-start check	<p>A safety checklist that is undertaken prior to first use of machinery or vehicles for that day or shift.</p>
PCP	<p>Principal control plan. A plan required under Regulation 92 of the MOQO Regulations.</p>
Principal hazard	<p>Has the meaning given in Regulation 65 of the MOQO Regulations. While alluvial mines and quarries are not legally required to appraise risks to determine principal hazards, for the purposes of this guidance we have described risks where multiple fatalities could occur as a principal hazard.</p>
Principal hazard management plan	<p>Means a plan required under regulation 66 of the MOQO Regulations.</p>
Prohibited zone	<p>Zone or area where people are not allowed such as at the bottom of a working tip face, the loading zone around vehicles, or the area at risk from hazards such as vehicle fire with potential tyre explosion.</p>
PTW	<p>Permit to Work. A Permit to Work system is a formal documented process used to manage work identified as significantly hazardous by making sure all safety measures are in place before work starts.</p>
Quarrying operation	<p>A quarrying operation is an activity carried out above ground for:</p> <ul style="list-style-type: none"> - extracting any material (excluding coal or any mineral), from the earth, or - for processing any material (excluding coal or any mineral) at the place where it was extracted or at a place adjacent to, or in the vicinity of, that place. <p>It includes the place where the extracting or processing was carried out.</p>
Quarry operator	<p>Means a person who controls a quarrying operation and, in relation to a particular quarrying operation, means the person who controls that operation.</p>
Reasonably practicable So far as is reasonably practicable	<p>Certain legal requirements require you to do something 'so far as is reasonably practicable'. 'Reasonably practicable' is the term used to describe what you need to think about when deciding how to meet certain health and safety duties. There are two parts to 'reasonably practicable'.</p> <p>You first consider what is possible in your circumstances to ensure health and safety. You then consider, of these possible actions, what is reasonable to do in your circumstances.</p> <p>You need to achieve a result that provides the highest protection that is reasonably practicable in your circumstances.</p> <p>For more information see Reasonably practicable</p>
Responsible person	<p>The responsible person for:</p> <ul style="list-style-type: none"> - a tourist mining operation, suspended mining operation or a coal exploration operation is the mine operator - a quarry is the quarry operator - an alluvial mine is the alluvial mine operator - any other mining operation is the site senior executive.

TERM	DEFINITION												
Restricted area or restricted access	Area or zone where people or vehicles are not allowed unless certain conditions are met. For example, entry to an electrical switchboard room may be restricted to maintenance personnel under a permit to work; light vehicles may be restricted to entering a vehicle operating area when traffic has been stopped.												
Riprap	A layer of large, quarried stone, precast blocks, bags of cement, or other suitable material, generally placed on the slope of an embankment or along a watercourse as protection against wave action, erosion, or scour. Riprap is usually placed by dumping or other mechanical methods, and in some cases is hand placed. It consists of rock pieces of relatively large size, as distinguished from a gravel blanket.												
ROPS	Roll-over protective structure. Protection for the driver and any passengers from a vehicle overturning.												
Safe work instrument	A written instruction that sets out how an activity is to be undertaken at an operation. It can be used for training or observing activities for monitoring or review.												
SDS	Safety Data Sheet.												
Shotfirer	The competent person in charge of, and responsible for, the loading and firing of a blast.												
Should	When 'should' is used in our guidance, it means a recommended practice or approach.												
Site	A place of work where extractive operations (mining and quarrying) and/or associated activities are carried out.												
Sleep time	In relation to explosive use, sleep time is defined as the time between charging and firing the shot.												
Soils and very weak rock	<p>As defined by the NZ Geotechnical Society Incorporated Field Description of Soil Analysis Guideline (Dec 2005) Table 3.5 Rock Strength Terms being:</p> <table border="1"> <thead> <tr> <th>TERM</th> <th>FIELD IDENTIFICATION OF SPECIMEN</th> <th>UNCONFINED UNIAXIAL COMPRESSIVE STRENGTH q_u (MPa)</th> <th>POINT LOAD STRENGTH $I_{s(50)}$ (MPa)</th> </tr> </thead> <tbody> <tr> <td>Very weak</td> <td>Crumbles under firm blows with point of geological hammer Can be peeled by a pocket knife</td> <td>1-5</td> <td><1</td> </tr> <tr> <td>Extremely weak (also needs additional description in soil terminology)</td> <td>Indented by thumbnail or other lesser strength terms used for soils</td> <td><1</td> <td></td> </tr> </tbody> </table> <p>Note: No correlation is implied between q_u and $I_{s(50)}$</p>	TERM	FIELD IDENTIFICATION OF SPECIMEN	UNCONFINED UNIAXIAL COMPRESSIVE STRENGTH q_u (MPa)	POINT LOAD STRENGTH $I_{s(50)}$ (MPa)	Very weak	Crumbles under firm blows with point of geological hammer Can be peeled by a pocket knife	1-5	<1	Extremely weak (also needs additional description in soil terminology)	Indented by thumbnail or other lesser strength terms used for soils	<1	
TERM	FIELD IDENTIFICATION OF SPECIMEN	UNCONFINED UNIAXIAL COMPRESSIVE STRENGTH q_u (MPa)	POINT LOAD STRENGTH $I_{s(50)}$ (MPa)										
Very weak	Crumbles under firm blows with point of geological hammer Can be peeled by a pocket knife	1-5	<1										
Extremely weak (also needs additional description in soil terminology)	Indented by thumbnail or other lesser strength terms used for soils	<1											
SSE	Site senior executive. A worker appointed as the site senior executive by the mine operator.												
SOP	Standard operating procedure. The documented, often step-by-step, processes by which workers can perform each task or aspect of the operation.												
Stockpile	Material placed, usually on a temporary basis, that is recovered and replaced.												

TERM	DEFINITION																								
Stronger rock	<p>As defined by the NZ Geotechnical Society Incorporated Field Description of Soil Analysis Guideline (Dec 2005) Table 3.5 Rock Strength Terms being:</p> <table border="1" data-bbox="496 353 1394 1234"> <thead> <tr> <th data-bbox="496 416 663 454">TERM</th> <th data-bbox="663 365 890 454">FIELD IDENTIFICATION OF SPECIMEN</th> <th data-bbox="890 365 1193 454">UNCONFINED UNIAXIAL COMPRESSIVE STRENGTH q_u (MPa)</th> <th data-bbox="1193 365 1394 454">POINT LOAD STRENGTH $I_{s(50)}$ (MPa)</th> </tr> </thead> <tbody> <tr> <td data-bbox="496 483 663 544">Extremely strong</td> <td data-bbox="663 465 890 555">Can only be chipped with geological hammer</td> <td data-bbox="890 483 1193 544">>250</td> <td data-bbox="1193 483 1394 544">>10</td> </tr> <tr> <td data-bbox="496 595 663 633">Very strong</td> <td data-bbox="663 573 890 663">Requires many blows of geological hammer to break it</td> <td data-bbox="890 595 1193 656">100–250</td> <td data-bbox="1193 595 1394 656">5–10</td> </tr> <tr> <td data-bbox="496 707 663 745">Strong</td> <td data-bbox="663 685 890 775">Requires more than one blow of geological hammer to break it</td> <td data-bbox="890 707 1193 768">50–100</td> <td data-bbox="1193 707 1394 768">2–5</td> </tr> <tr> <td data-bbox="496 864 663 925">Moderately strong</td> <td data-bbox="663 797 890 976">Cannot be scraped or peeled with a pocketknife Can be broken with single firm blow of geological hammer</td> <td data-bbox="890 864 1193 925">20–50</td> <td data-bbox="1193 864 1394 925">1–2</td> </tr> <tr> <td data-bbox="496 1088 663 1126">Weak</td> <td data-bbox="663 999 890 1223">Can be peeled by a pocketknife with difficulty Shallow indentations made by firm blow with point of geological hammer</td> <td data-bbox="890 1088 1193 1149">5–20</td> <td data-bbox="1193 1088 1394 1149"><1</td> </tr> </tbody> </table> <p data-bbox="496 1245 1394 1279">Note: No correlation is implied between q_u and $I_{s(50)}$</p>	TERM	FIELD IDENTIFICATION OF SPECIMEN	UNCONFINED UNIAXIAL COMPRESSIVE STRENGTH q_u (MPa)	POINT LOAD STRENGTH $I_{s(50)}$ (MPa)	Extremely strong	Can only be chipped with geological hammer	>250	>10	Very strong	Requires many blows of geological hammer to break it	100–250	5–10	Strong	Requires more than one blow of geological hammer to break it	50–100	2–5	Moderately strong	Cannot be scraped or peeled with a pocketknife Can be broken with single firm blow of geological hammer	20–50	1–2	Weak	Can be peeled by a pocketknife with difficulty Shallow indentations made by firm blow with point of geological hammer	5–20	<1
TERM	FIELD IDENTIFICATION OF SPECIMEN	UNCONFINED UNIAXIAL COMPRESSIVE STRENGTH q_u (MPa)	POINT LOAD STRENGTH $I_{s(50)}$ (MPa)																						
Extremely strong	Can only be chipped with geological hammer	>250	>10																						
Very strong	Requires many blows of geological hammer to break it	100–250	5–10																						
Strong	Requires more than one blow of geological hammer to break it	50–100	2–5																						
Moderately strong	Cannot be scraped or peeled with a pocketknife Can be broken with single firm blow of geological hammer	20–50	1–2																						
Weak	Can be peeled by a pocketknife with difficulty Shallow indentations made by firm blow with point of geological hammer	5–20	<1																						
Structure	Defined in HSWA as anything that is constructed, whether fixed moveable, temporary or permanent - including buildings, masts, towers, frameworks, pipelines, bridges, quarries, shafts or tunnels - as well as any component or part of a structure.																								
Tip	May include an overburden tip or waste material tip of a permanent nature. Often called waste dumps or waste rock stacks.																								
Toe	The toe of the slope is the interior vertex where the bench face and bench floor intersect.																								
Tourist mining operation	means an operation that has the purpose of: <ul style="list-style-type: none"> a. mine education b. mine research, or c. mine tourism. 																								
Vehicle operating areas	Other vehicle operating areas are all areas on or at a site where operations involve the use of vehicles other than roads. For example, tip points, stockpiles or loading areas. It includes any vehicle operating areas used by the public within the site boundaries.																								
WLL	Working load limit. The maximum working load designed by the manufacturer.																								
Workplace	A workplace is where work is carried out. It includes any location where a worker goes or is likely to be while working.																								

TERM	DEFINITION
Worker	<p>A worker is someone who carries out work for a PCBU, like:</p> <ul style="list-style-type: none"> - employees - contractors or sub-contractors - employees of contractors or sub-contractors - outworkers (including homeworkers) - apprentices and trainees - people gaining work experience or on a work trial - volunteer workers - self-employed people (who are PCBUs as well as workers). <p>Workers have health and safety duties. For more information see Worker duties</p>
Working bench	The level on which the excavator is sitting on, or the trucks are running on.

Appendix B: References

Legislation

All listed legislation can be found at legislation.govt.nz

- [Health and Safety at Work Act 2015 \(HSWA\)](#)
- [Health and Safety at Work \(Mining Operations and Quarrying Operations\) Regulations 2016 \(the MOQO Regulations\)](#)
- [Health and Safety at Work \(General Risk and Workplace Management\) Regulations 2016 \(the GRWM Regulations\)](#)
- [Health and Safety at Work \(Worker Engagement, Participation, and Representation\) Regulations 2016](#)
- [Health and Safety at Work \(Hazardous Substances\) Regulations 2017 \(the Hazardous Substances Regulations\)](#)
- [Health and Safety in Employment \(Pressure Equipment, Cranes and Passenger Ropeways\) Regulations 1999](#)
- [The Building Act 2004](#)
- [Building \(Dam Safety\) Regulations 2022](#)
- [The Building Regulations 1992 \(Building Code\)](#)
- [Electricity Act 1992](#)
- [Electricity \(Safety\) Regulations 2010](#)
- [The Land Transport Act 1998](#)
- [The Land Transport Act 1998 Land Transport Rule: Vehicle Lighting 2004](#)
- [Maritime Transport Act 1994](#)
- [Maritime Transport Act 1994 Maritime Rules](#)

WorkSafe publications

- Approved Code of Practice for Excavations for Shafts and Foundations.
- Approved Code of Practice for Cranes
- Approved Code of Practice for Load-lifting Rigging
- Approved Code of Practice for Managing Hazards to Prevent Major Industrial Accidents
- Approved Code of Practice for Operator Protective Structures on Self-Propelled Mobile Mechanical Plant
- Approved Code of Practice for the Management of Noise in the Workplace
- Approved Code of Practice for Training Operators and Instructors of Powered Industrial Lift Trucks (Forklifts)
- Best Practice Guidelines for the Safe use of Machinery
- New Zealand Electrical Code of Practice for Electrical Safe Distances (NZECP 34:2001)
- Best Practice Guidelines for Working at Height
- Ergonomics of Machine Guarding Guide
- Fact sheet: A Hazard Management System for Mining Operations
- Guide to Health and Safety in Welding
- Guidelines for the Management of Work in Extremes of Temperature
- Interpretive guidelines for the Health and Safety at Work (General Risk and Workplace Management) Regulations 2016
- Quick guide – Managing health risks in the extractives industry
- Quick guide – First aid at work
- Quick guide – Safe Working in a Confined Space
- Safety Code for Forklift Truck Operators: Front Loading Forklift Trucks

- Welding Health and Safety Assessment Tool
- Workplace Exposure Standards
- Writing Health and Safety Documents for your Workplace

Other publications

- MinEx [Guide to Worker Health in Extractives](#)
- Department of Building and Housing [Compliance Document for New Zealand Building Code Clause D1 Access Routes](#) and [Compliance Document for New Zealand Building Code Clause F4 Safety from Falling](#)
- Maritime New Zealand Barge [Stability Guidelines](#)
- Ministry of Consumer Affairs [New Zealand Electrical Code of Practice for Electrical Safe Distances \(NZECP 34:2001\)](#)
- New Zealand Geotechnical Society Inc [Field Description of Soil and Rock: Guideline for the Field Classification and Description of Soil and Rock for Engineering Purposes](#)
- New Zealand Transport Agency (NZTA) [The official New Zealand Truck Loading Code](#)
- NZTA [Heavy Vehicle Stability Guide](#)
- Global Mining Guidelines Group [guide on autonomous equipment Guideline for the Implementation of Autonomous Systems in Mining - Version 2](#)

Website links

- [WorkSafe's examples of notifiable events](#)
- [WorkSafe's information on the requirements and application process for Certificates of Competence](#)
- [WorkSafe's emergency procedure flipchart](#)
- Civil Defence: [National Emergency Management Agency - Coordinated Incident Management System \(CIMS\)](#)
- NZTA: [Information on transport law and road signs and markings](#)
- NZTA: [Information on drivers medical](#)
- Maritime NZ: [Information on maritime law and associated requirements](#)
- Building Performance: [Information on inspecting small dams, constructing small dams or the Building Code](#)

Standards

See the [Standards New Zealand website](#)

- *AS 2187.2-2006 Explosives - Storage and Use Part 2: Use of explosives*
- *AS 2359.13-2005 Powered industrial trucks - Brake performance and component strength*
- *AS 2359.2-2013 Powered industrial trucks - Operations*
- *AS 2865-2009 Confined Spaces*
- *AS 2958.1-1995 Earth-moving machinery - Safety - Wheeled machines - Brakes*
- *AS 4024.1-2006 Series Safety of machinery*
- *AS 4457.1-2007 Earth Moving Machinery - Off-the-road wheels, rims and tyres - Maintenance and repair - Wheel assemblies and rim assemblies*
- *AS/NZS 1270:2002 Acoustics - Hearing protectors*
- *AS/NZS 1337.1:2010 Personal eye protection - Eye and face protectors for occupational applications*
- *AS/NZS 1657:1992 Fixed platforms, walkways, stairways and ladders. Design, construction and installation*

- *AS/NZS 1715:2009 Selection, use and maintenance of respiratory protective equipment*
- *AS/NZS 1716:2012 Respiratory protective devices*
- *AS/NZS 1801:1997 Occupational protective helmets*
- *AS/NZS 1892.1:1996 Portable ladders - Part 1: Metal*
- *AS/NZS 2161.2:2005 Occupational protective gloves - General requirements*
- *AS/NZS 2161.3:2005 Occupational protective gloves - Protection against mechanical risks*
- *AS/NZS 2210.1:2010 Safety, protective and occupational footwear - Guide to selection, care and use*
- *AS/NZS 2801:2008 Clothing for protection against heat and flame - General recommendations for selection, care and use of protective clothing*
- *AS/NZS 2906:2001 Fuel containers - Portable - Plastics and metal*
- *AS/NZS 3007:2013 Electrical equipment in mines and quarries - Surface installations and associated processing plant*
- *AS/NZS 3760:2010 In-service safety inspection and testing of electrical equipment*
- *AS/NZS 4602.1:2011 High visibility safety garments - Part 1: Garments for high risk applications*
- *AS/NZS ISO 31000:2009 Risk Management - Principles and Guidelines*
- *ASTM F852-08 Standard Specification for Portable Gasoline Containers for Consumer Use*
- *NZS 5823:1989 Specification for buoyancy aids and marine safety harnesses and lines*
- *NZS 5823:2001 Specification for buoyancy aids and marine safety harnesses and lines*
- *NZS 5823:2005 Specification for buoyancy aids and marine safety harnesses and lines*
- *SA/SNZ HB 436:2013 Risk management guidelines - Companion to AS/NZS ISO 31000:2009*
- *SA/SNZ HB 89:2013 Risk Management - Guidelines on risk assessment techniques*

Appendix C: Health and Safety at Work Act duties

The [Health and Safety at Work Act 2015](#) (HSWA) is New Zealand’s key work health and safety law.

All work and workplaces are covered by HSWA unless they have been specifically excluded. For example, HSWA does not apply to the armed forces in certain situations.

HSWA sets out the work health and safety duties that duty holders must comply with.

There are four types of duty holder under HSWA:

- a person conducting a business or undertaking (PCBU)
- an officer
- a worker
- an ‘other person’ at the workplace.

Most duties under HSWA relate to **how** work is carried out. However some duties are linked to **where** work is carried out: the workplace.

A **workplace** is a place where work is being carried out or usually carried out for a business or undertaking. It includes any place where a worker goes or is likely to be while at work [section 20 of HSWA](#)

DUTY HOLDER	WHO THEY ARE?	EXAMPLES	WHAT ARE THEIR DUTIES?	FOR MORE INFORMATION
Person Conducting a Business or Undertaking (PCBU)	<p>A person conducting a business or undertaking (PCBU) may be an individual person or an organisation</p> <p>The following are not PCBUs:</p> <ul style="list-style-type: none"> - officers - workers - other persons at a workplace - volunteer associations that do not have employees - home occupiers (such as home owners or tenants) who pay someone to do work around the home section 17 of HSWA 	<ul style="list-style-type: none"> - a business - a self-employed person - partners in a partnership - a government agency - a local council - a school or university. 	<p>A PCBU has many duties. Key duties are summarised below.</p> <p>Primary duty of care section 36 of HSWA</p> <p>A PCBU must ensure, so far as is reasonably practicable, the health and safety of workers, and that other persons are not put at risk by its work.</p> <p>Managing risks section 30 of HSWA</p> <p>Risks to health and safety arise from people being exposed to hazards (anything that can cause harm). A PCBU must manage work health and safety risks.</p> <ul style="list-style-type: none"> - A PCBU must first try to eliminate a risk so far as is reasonably practicable. This can be done by removing the source of harm <ul style="list-style-type: none"> - for example, removing faulty equipment or a trip hazard. - If it is not reasonably practicable to eliminate the risk, it must be minimised so far as is reasonably practicable. <p>Overlapping duties: working with other PCBUs section 34 of HSWA</p> <p>A PCBU with overlapping duties must, so far as is reasonably practicable, consult, cooperate and coordinate activities with other PCBUs they share duties with.</p>	<p>Introduction to the Health and Safety at Work Act 2015</p> <p>Appendix D of this guidance for an explanation of ‘so far as is reasonably practicable’</p> <p>Identifying, assessing and managing work risks</p> <p>Section 2.5 of this guidance</p> <p>Appendix E of this guidance</p>

DUTY HOLDER	WHO THEY ARE?	EXAMPLES	WHAT ARE THEIR DUTIES?	FOR MORE INFORMATION
			<p>Involving workers: worker engagement, participation and representation Part 3 of HSWA</p> <p>A PCBU must, so far as is reasonably practicable, engage with their workers (or their workers' representatives) about health and safety matters that will directly affect the workers.</p> <p>A PCBU must have worker participation practices that give their workers reasonable opportunities to participate in improving health and safety on an ongoing basis.</p>	Appendix F of this guidance
Upstream PCBU	A PCBU in the supply chain	<ul style="list-style-type: none"> - a designer - a manufacturer - a supplier - an importer - an installer, constructor, or commissioner. 	<p>Upstream PCBU sections 39–43 of HSWA</p> <p>An upstream PCBU must ensure, so far as is reasonably practicable, that the work they do or the things they provide to other workplaces do not create health and safety risks.</p>	<p>Introduction to the Health and Safety at Work Act 2015</p> <p>Appendix G of this guidance</p>
Officer	A specified person or a person who exercises significant influence over the management of the business or undertaking section 18 of HSWA	<ul style="list-style-type: none"> - a company director - a partner or general partner - a chief executive. 	<p>Officer section 44 of HSWA</p> <p>An officer must exercise due diligence that includes taking reasonable steps to ensure that the PCBU meets their health and safety duties.</p>	<p>Introduction to the Health and Safety at Work Act 2015</p>
Worker	An individual who carries out work for a PCBU section 19 of HSWA	<ul style="list-style-type: none"> - an employee - a contractor or sub-contractor - an employee of a contractor or sub-contractor - an employee of a labour hire company - an outworker (including homeworker) - an apprentice or trainee - a person gaining work experience or on work trials - a volunteer worker. 	<p>Worker section 45 of HSWA</p> <p>A worker must take reasonable care of their own health and safety, and take reasonable care that they do not harm others at work.</p> <p>A worker must cooperate with reasonable policies and procedures the PCBU has in place that the worker has been told about.</p> <p>A worker must comply, as far as they are reasonably able, with any reasonable instruction given by the PCBU so the PCBU can meet their legal duties.</p>	<p>Introduction to the Health and Safety at Work Act 2015</p>
Other person at the workplace	An individual present at a workplace (not a worker)	<ul style="list-style-type: none"> - a workplace visitor - a casual volunteer (not a volunteer worker) - a customer. 	<p>Other person at the workplace section 46 of HSWA</p> <p>An 'other person' has a duty to take reasonable care of their own health and safety, and not adversely affect the health and safety of anyone else.</p> <p>They must comply with reasonable instructions relating to health and safety at the workplace.</p>	<p>Introduction to the Health and Safety at Work Act 2015</p>

Appendix D: So far as is reasonably practicable

section 22 of HSWA

Certain PCBU duties ([sections 36–43](#) duties including the primary duty of care) must be carried out ‘so far as is reasonably practicable’.

What to consider when deciding what is ‘reasonably practicable’

Just because something is possible to do, does not mean it is reasonably practicable in the circumstances.

Consider:

- What possible actions can be taken to ensure health and safety?
- Of these possible actions, at a particular time, what is reasonable to do?

Think about the following questions.

WHAT IS KNOWN ABOUT THE RISK?

- How likely is the risk to occur?
- How severe is the illness or injury that might occur if something goes wrong?
- What is known, or should reasonably be known, about the risk?

WHAT IS KNOWN ABOUT POSSIBLE CONTROL MEASURES?

- What is known, or should reasonably be known, about the ways (control measures) to eliminate or minimise the risk?
- What control measures are available?
- How appropriate (suitable) are the control measures to manage the risk?
- What are the costs of these control measures?
- Are the costs grossly disproportionate to the risk? Cost must only be used as a reason to not do something when that cost is grossly out of proportion to the risk.

While PCBUs should check if there are widely used control measures for that risk (such as industry standards), they should always keep their specific circumstances in mind. A common industry practice might not be the most effective or appropriate control measure to use.

If PCBUs are not sure what control measures are appropriate, WorkSafe recommends getting advice from a suitably qualified and experienced health and safety professional.

For more information, see our guidance [Reasonably practicable](#)

Appendix E: Working with other PCBUs – overlapping duties

section 34 of HSWA

More than one PCBU can have a duty in relation to the same matter. These PCBUs have overlapping duties – this means that the duties are shared between them.

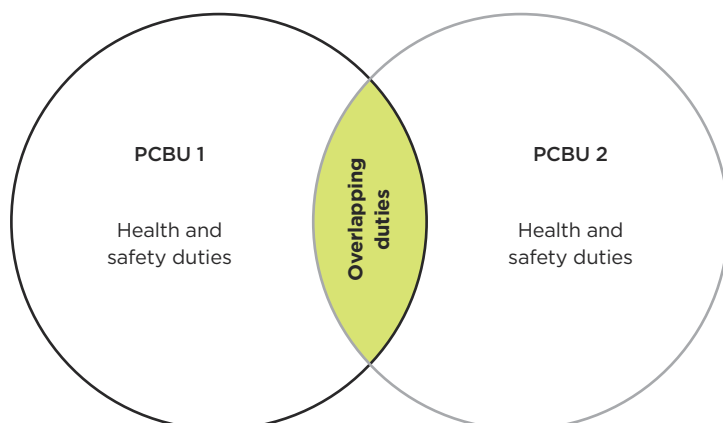

Duties regularly overlap:

- in a shared workplace (for example, a building site or a port) where more than one business has control and influence over the work on site.
- in a contracting chain, where contractors and subcontractors provide services to a head contractor or client and do not necessarily share the same workplace.

A PCBU must, so far as is reasonably practicable, consult, cooperate and coordinate activities with all other PCBUs they share duties with so that all PCBUs can meet their joint responsibilities.

A PCBU cannot transfer or contract out of their duties, or pass liability to another person.

However a PCBU can make an agreement with another PCBU to fulfil specific duties. Even if this occurs, all PCBUs are still responsible for meeting their legal duties.

Example

A local hotel contracts out housekeeping services to an agency. The hotel and agency both have a duty to ensure the health and safety of the housekeeping workers, so far as is reasonably practicable. This includes the duty to provide first aid facilities.

The agency reaches an agreement with the hotel – if their workers need first aid while working at the hotel they can use the hotel's first aid facilities.

For more information, see our guidance [Overlapping duties](#)

Appendix F: Worker engagement, participation and representation Part 3 of HSWA

Engage with workers and enable their participation

A PCBU has two main duties related to worker engagement and participation:

- to engage with workers on health and safety matters that affect or are likely to affect workers, so far as is reasonably practicable, and
- to have practices that give workers reasonable opportunities to participate effectively in the ongoing improvement of work health and safety.

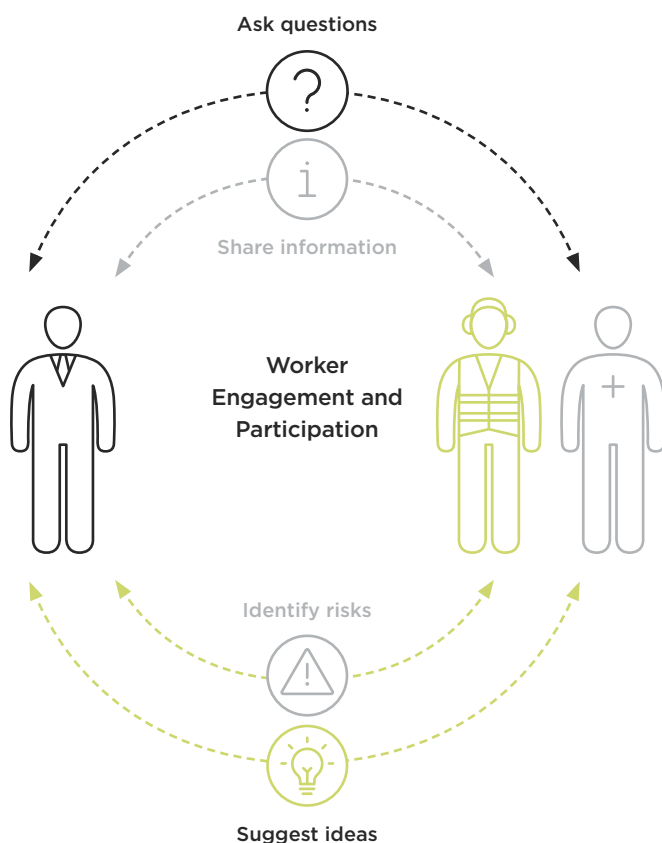

A PCBU can engage with workers by:

- sharing information about health and safety matters so that workers are well-informed, know what is going on and can contribute to decision-making
- giving workers reasonable opportunities to have a say about health and safety matters
- listening to and considering what workers have to say at each step of the risk management process
- considering workers' views when health and safety decisions are being made
- updating workers about what decisions have been made.

A PCBU must engage with workers during specified times, including when identifying hazards and assessing risks.

A PCBU must have clear, effective, and ongoing ways for workers to suggest improvements or raise concerns.

Worker representation

Workers can be represented by a Health and Safety Representative (HSR), a union representing workers, or a person that workers authorise to represent them (for example, a community or church leader, or another trusted member of the community).

HSRs and Health and Safety Committees (HSCs) are two well-established methods of participation and representation. If workers are represented by an HSR, worker engagement must also involve that representative.

For more information

WORKSAFE GUIDANCE

Good practice guidelines

[Worker engagement, participation and representation](#)

Interpretive guidelines

[Worker representation through Health and Safety Representatives and Health and Safety Committees](#)

Pamphlets

[Worker representation](#)

[Health and Safety Committees](#)

[Health and Safety Representatives](#)

Appendix G: Upstream duties [sections 39–43 of HSWA](#)

A PCBU in the supply chain (upstream) also has a duty to ensure, so far as is reasonably practicable, that the work they do or the things they provide to other workplaces do not create health and safety risks.

An upstream PCBU is a business that:

- designs plant, substances, or structures
- manufactures plant, substances, or structures
- imports plant, substances, or structures
- supplies plant, substances, or structures
- installs, constructs or commissions plant or structures.

Upstream businesses are in a strong position to eliminate or minimise risk. They can influence and sometimes eliminate health and safety risks through designing, manufacturing, importing or supplying products that are safe for the end user.

Example

A worker using a badly designed or poorly manufactured saw may be at risk of injury. This risk should have been eliminated or minimised, so far as was reasonably practicable, by the designer or manufacturer.

For more information, see our website worksafe.govt.nz

Upstream duties for designers [section 39 of HSWA](#)

A designer creates or modifies a design for plant, substances or structures that are to be used or operated, or could be used or operated, in a workplace.

A designer has a duty, so far as is reasonably practicable:

- to make sure the products they design do not create health and safety risks for the people that use them and those nearby
- to make sure the products they design have been tested so they are safe for use in a workplace
- to give the following information to those who will use the designed products:
 - the design's purpose or intended use
 - the results of any calculations or tests
 - any general and current relevant information about how to safely use, handle, store, construct, inspect, clean, maintain, repair, or otherwise work near the designed products.

These requirements apply across the product's entire lifecycle - from manufacture and construction, through to everyday use, decommissioning and disposal.

For more information, see our guidance [Health and safety duties for businesses that design products for workplaces](#)

Upstream duties for manufacturers [section 40 of HSWA](#)

A manufacturer makes plant, substances or structures that are to be used, or could be used or operated, in a workplace.

A manufacturer has a duty, so far as is reasonably practicable:

- to make sure the products they manufacture do not create health and safety risks for the people that use them and those nearby
- to make sure the products they manufacture have been tested so they are safe for use in a workplace

- to give the following information to those that will use the manufactured products:
 - the purpose or intended use of each product
 - the results of any calculations and tests
 - any general and current relevant information about how to safely use, handle, store, construct, inspect, clean, maintain, repair, or otherwise work near the manufactured products.

These requirements apply across the product's entire lifecycle - from manufacture and construction, through to everyday use, decommissioning and disposal.

For more information, see our guidance [Health and safety duties for businesses that manufacture products for workplaces](#)

Upstream duties for importers [section 41 of HSWA](#)

An importer imports plant, substances or structures that are to be used, or could be used or operated, in a workplace.

An importer is a business:

- that goods are imported **by**, or
- that goods are imported **for**.

Importation is another word for importing. Importation refers to the **arrival of goods** in New Zealand from a point outside New Zealand. These goods can arrive in any manner.

An importer has a duty, so far as is reasonably practicable:

- to make sure the products they import do not create health and safety risks for the people that use them and those nearby
- to make sure the products they import have been tested so they are safe for use in a workplace
- to give the following information to those who will use the imported products:
 - the purpose or intended use of each product
 - the results of any calculations and tests
 - any general and current relevant information about how to safely use, handle, store, construct, inspect, clean, maintain, repair, or otherwise work near the imported products.

These requirements apply across the product's entire lifecycle - from construction or assembly, through to everyday use, decommissioning and disposal.

Imported products must also meet all New Zealand regulatory requirements relevant to that product.

For more information, see our guidance [Health and safety duties for businesses that import products for workplaces](#)

Upstream duties for suppliers [section 42 of HSWA](#)

A supplier supplies plant, structures or substances that may be used in a workplace.

A supplier has a duty, so far as is reasonably practicable:

- to make sure the products they supply do not create health and safety risks for the people that use them and those nearby
- to make sure the products they supply have been tested so they are safe for use in a workplace

- to give the following information to those who will use the supplied products:
 - the purpose or intended use of each product
 - the results of any calculations and tests
 - any general and current relevant information about how to safely use, handle, store, construct, inspect, clean, maintain, repair, or otherwise work near the supplied products.

These duties do not extend to the sale of second-hand plant sold 'as is'.

These requirements apply across the product's entire lifecycle - from construction or assembly, through to everyday use, decommissioning and disposal.

For more information, see our guidance [Health and safety duties for businesses that supply products for workplaces](#)

Upstream duties for installers, constructors or commissioners of plant or structures [section 43 of HSWA](#)

An installer/constructor builds and/or assembles and installs plant and structures that may be used at a workplace. A commissioner performs adjustments, tests and inspections on plant and structures before they are used for the first time in a workplace.

An installer, constructor or commissioner has a duty, so far as is reasonably practicable, to make sure that the way the plant or structure is installed, constructed or commissioned does not create health and safety risks to the people that come into contact with it across the product's entire lifecycle - from construction or assembly, through to everyday use, decommissioning and disposal.

For more information, see our guidance [An additional health and safety duty for businesses that install, construct or commission plant or structures for workplaces](#)

Disclaimer

This publication provides general guidance. It is not possible for WorkSafe to address every situation that could occur in every workplace. This means that you will need to think about this guidance and how to apply it to your particular circumstances.

WorkSafe regularly reviews and revises guidance to ensure that it is up-to-date. If you are reading a printed copy of this guidance, please check worksafe.govt.nz to confirm that your copy is the current version.

ISBN 978-1-99-105745-7 (online)

Published: June 2025

PO Box 165, Wellington 6140, New Zealand

worksafe.govt.nz



Except for the logos of WorkSafe, this copyright work is licensed under a Creative Commons Attribution-Non-commercial 3.0 NZ licence.

To view a copy of this licence, visit <http://creativecommons.org/licenses/by-nc/3.0/nz>

In essence, you are free to copy, communicate and adapt the work for non-commercial purposes, as long as you attribute the work to WorkSafe and abide by the other licence terms.

